

Televés®



MOSAIQ₆ 

Refs. 596101, 596111

EN Multi-touch Meter / Analyser

User manual

Index

Index	3	Web application	59
Safety requirements	4	1.- Measurements	59
Symbols and safety labels	4	2. Plans	61
Introducing the MOSAIQ6	5	3. SCR	63
Key features	5	4. Quality profiles	63
General Specifications	6	5. User profiles	63
Technical Specifications	7	6. Antenna profile	64
Description of equipment components	9	7. Clone	64
Connectors and controls	9	8. Licenses	64
Keyboard	9	9. Remote control	64
Power supply	10	10. Configuration	65
About the battery	10	MOSAIQ6 Cloud	65
Separately battery charge	11	Error messages	66
Gestures	12	Technical support	67
Before starting	12	Repair service	67
Icons on the screen	14	Warranty	68
Bottom bar:	14		
Top bar:	16		
Menus	17		
Top Menu	17		
Main Menu	17		
Options context menu	17		
Top menu	17		
Inputs/Outputs:	17		
Powering:	18		
Settings:	19		
Main menu	21		
1. Settings	21		
2. User Manual	23		
3. User profiles	23		
4. Optical attenuation	25		
5. Satellite identification	26		
6. LTE check	27		
7. TV Analyser	28		
8. Spectrum analyser	44		
9. Radio Analyser	46		
10. Wi-Fi Analyser	50		
11. Network Tools	53		
12. Drive Test	55		
13. LOGS	58		

Safety requirements

● Product inspection

- Inspect the equipment for shipping damage. Should any damage be discovered, immediately file a claim with the carrier.

● Read and Follow All Instructions

- All the safety and operating instructions should be read prior to and followed while operating this product.

● Do not obstruct the ventilation slots

● Cleaning

- Follow the cleaning instructions contained in the Maintenance section of this manual.

● Attachments

- Do not use attachments that are not approved by the product manufacturer

● Water and Moisture

- This product is splash water resistant but is not submersible.
- Do not place objects filled with liquids on or near the meter, such as glasses.

● Power Sources

- This product should be operated only from the type of power source specified (12VDC - 4A).
- Ensure that the voltage applied to the power connector does not exceed 15V. Higher voltages could damage the equipment
- Maximum consumed current: 4A

● Grounding or Polarization

- Do not bypass or defeat electrical plug polarization or grounding. Doing so will violate the warranty and may pose a risk of fire or electrocution.

● RF connector electrical protection

- Maximum VAC: 18VAC
- Maximum positive VDC: 58V
- Maximum negative VDC: -18V

● Wire Protection

- Ensure all connected wiring is routed correctly to avoid damage including pinching, excessive bends, or compression.

● Electrical Supply, Grounding, and Surge Protection

- Ensure that all local or national electrical codes are followed.

● Power Lines

- Always use caution and avoid operating this or any connected equipment near uninsulated

power lines or any other hazards.

● Servicing

- There are no user serviceable parts except the battery pack. Do not attempt to service this product or remove covers. Refer all servicing to qualified service personnel. Follow the instructions in this manual when replacing the battery.

● Heat

- The product should be situated away from heat sources such as radiators, heat registers, stoves, or other products that produce heat..
- Do not place naked flame sources on the meter, such as lighted candles.

● Battery pack

- Battery must be replaced by the battery pack supplied by the manufacturer (ref. 596210) only. In no case the battery pack cover can be opened.
- This product should be operated only from the type of power source specified (12VDC - 4A).
- Ensure that the voltage applied to the power connector does not exceed 15V. Higher voltages could damage the equipment
- May explode if damaged or disposed of in fire or water

● Class

- Operation of this equipment in a residential environment may cause radio interference.

Symbols and safety labels



Recycle or dispose of used electronic devices properly.



The equipment contains a recyclable battery. Before depositing the equipment in the container of electrical and electronic equipment, you must remove the battery pack and deposit it separately for proper management



Battery can only be replaced by the battery pack supplied by the manufacturer (ref. 596210)

Overview

Introducing the MOSAIQ6

MOSAIQ6 is the new high-performance portable meter, with advanced features and high measurement accuracy. And all in the most automatic and intuitive way in the market, thanks to its intuitive interface and gestural commands.

With **MOSAIQ6**, technicians have a tool to measure, analyse and diagnose radio and TV signals in any scenario, no matter how complex.

MOSAIQ6 has an ultra-fast spectrum analyser with high accuracy, together with the echoes analysis features, allows to detect any important issue of the signal.

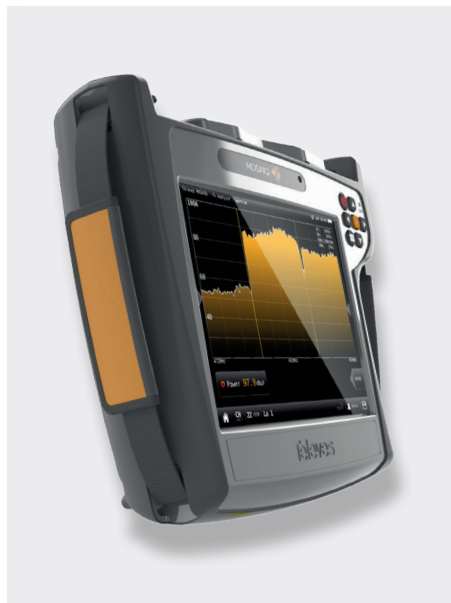

Key features

- **High performance portable meter**
- **Intuitive.** Thanks to its novel interface, designed to get the most out of its multi-touch 8" screen.
- **All the information about the signal in one screen.** Mosaicq feature, with up to 6 widgets configurable by the user.
- **Powerful digital spectrum analyser** (scanning < 10ms.) 5MHz - 3.3GHz range.
- **Easily updateable**
- Spectrum analyser with **selectable span**
- **Specific measurements over IP** (TSolP)
- **PASS/FAIL indicators:** Icons indicate if a measurement is good, bad or in the warning zone for quick and easy status check. Reduce installer entry errors and improve decision making.
- **Field-swappable** and separately rechargeable **battery**
- **User profiles** customization
- Automatic **channel scan**
- Automatic **satellite identification**
- **GPS for drive test** and automatic saving of measurements
- **LTE interferences** detection and simulation

General Specifications

Display	8" Touch Screen TFT 1024x768 Full Colour
Weight	2150g
Dimensions	250x210x60 mm (H x W x D)
Power supply	Input: 100-240V~ 50-60Hz Output: 12VDC, 4A
Battery	Li-ion (7,2VDC, 9000mAh). Field-swappable
Operating time	> 4 hours
Operating temperature	-5°C to 45°C (23°F to 104°F)
Storage temperature	-20°C to 70°C (-4°F to 158°F)
Humidity	5% to 95% without condensation
Interfaces	ETH, USB, HDMI, Audio Out (Jack), FC/APC optical fibre connector, GPS antenna connector
Storage	32 Gb

Technical Specifications

Frequency	
Range	5 - 3300 MHz
Accuracy	1 kHz
Tuning	Frequency or channel
Input	
Impedance	75 Ohm
Spectrum Analyzer	
Span	100 KHz, 1, 5, 10, 20, 50, 100, 200, 500 MHz, 1.0, 2.0 and 3.3 GHz. Other (any value between 100 KHz and 3.3 GHz)
RBW	500 Hz, 1, 3, 5, 10, 30, 50, 100, 300, 500 KHz, 1, 3, 5 MHz
Marks	Up to 6, with delta feature
Relative marks	✓
Event trigger	✓
Waterfall	✓
Hold feature	Maximum and minimum
Reference level	Automatic and manual
Digital measurements DVB-T	
Modulations	COFDM (QPSK, 16QAM, 64QAM)
Power	20 - 128dBuV
CBER	1.0E-2 - 1.0E-6
VBER	1.0E-2 - 1.0E-8
MER	Up to 40dB
C/N	Up to 52dB
Echoes	✓
MER by carrier	✓
Constellation	✓
Uncorrected packets	✓
TILT	✓
Attenuation	✓
Digital measurements DVB-T2	
Modulations	COFDM (QPSK, 16QAM, 64QAM and 256QAM)
Power	20 - 128dBuV
PreLDPCBER	1.0E-2 - 1.0E-6 (Pre LDPCBER)
PreBCHBER	1.0E-2 - 1.0E-8 (Pre BCHBER or Post LDPCBER)
Link Margin	Up to 30dB
MER	Up to 40dB
C/N	Up to 52dB
Echoes	✓
MER by carrier	✓
Constellation	✓
Uncorrected packets	✓
TILT	✓

Attenuation	✓
Multiple PLP	✓
Digital measurements QAM (Annex A/B/C)	
Modulations	4QAM, 16QAM, 32QAM, 64QAM and 256QAM
Power	20 - 128dBuV
Pre-BER	1.0E-2 - 1.0E-8
Post-BER	1.0E-2 - 1.0E-9
MER	Up to 40dB
C/N	Up to 52dB
Constellation	✓
Uncorrected packets	✓
TILT	✓
Attenuation	✓
Digital measurements ISDB-T/Tb	
Modulations	DQPSK, QPSK, 16QAM and 64QAM
Power	-100 dBm to 20 dBm
C/N	Up to 50 dB
MER	Up to 40dB
Pre-BER (by layer)	1.0E-2 - 1.0E-6
Post-BER (by layer)	1.0E-2 - 1.0E-8
Echoes	✓
Constellation	✓
Uncorrected packets	✓
TILT	✓
Attenuation	✓
Digital measurements DVB-S	
Wideband (only compatible HW)	250-2400 MHz
Power	20 - 128dBuV
CBER	1.0E-2 - 1.0E-6
VBER	1.0E-2 - 1.0E-8
MER	Up to 20dB
C/N	Up to 30dB
Constellation	✓
Uncorrected packets	✓
TILT	✓
Attenuation	✓
Digital measurements DVB-S2X	
Wideband (only compatible HW)	250-2400 MHz
Modulations	QPSK, 8PSK
Power	20 - 128dBuV
Link Margin	Up to 10dB
MER	Up to 20dB
C/N	Up to 30dB

Specifications are subject to change without notice.

PreLDPCBER	1.0E-2 - 1.0E-6 (Pre LDPCBER)
PreBCHBER	1.0E-2 - 1.0E-8 (Pre BCHBER or Post LDPCBER)
Constellation	✓
Uncorrected packets	✓
TILT	✓
Attenuation	✓
Multi TS	✓
PLS scrambling	✓
Digital measurements DVB-S2	
Wideband (only compatible HW)	250-2400 MHz
Modulations	QPSK, 8PSK, 8APSK, 16 APSK & 32 APSK
Power	20 - 128dBμV
Link Margin	Up to 10dB
MER	Up to 20dB
C/N	Up to 30dB
PreLDPCBER	1.0E-2 - 1.0E-6 (Pre LDPCBER)
PreBCHBER	1.0E-2 - 1.0E-8 (Pre BCHBER or Post LDPCBER)
Constellation	✓
Uncorrected packets	✓
TILT	✓
Attenuation	✓
Multi TS	✓
FM Measurements	
Level	✓
C/N	Up to 52dB
RDS	✓
DAB/DAB+ Measurements (Option 596204)	
Power	De 20 - 128 dBμV
MER	Up to 20 dB
C/N	Up to 30 dB
BER	9.9E-2 – 1.0E-6
Analog Measurements (Option 596203)	
Level	20 - 128dBμV
V/A	Up to 52dB
C/N	Up to 30dB
Features	
Up to 6 widgets user-customizable	✓
System Scan with measurements and learning plan	✓
LTE check (4G/5G)	✓
FO (-40, 7 dBm)	Option 596101
FO Selective (-40, 7 dBm)	Option 596111
GPS Drive Test	Option 596201

MPEG2, MPEG4 Full HD Channels visualization	✓
4K visualization	✓
Info MPEG	SID, VID, AID, Resolution, Profile , Audio Bitrate, Video Bitrate, Resolution info
IPTV Analyzer	✓
Wi-Fi Analyser	2,4 GHz and 5 GHz (Option 596202)
Units	dBμV, dBmV, dBm
Network Tools	✓
Cloud	✓
Preamp powering	
Preamp powering	5, 13, 18, 24Vdc and other (any value between 5 and 24V)
Maximum supplied power	12 W
Maximum supplied current	900 mA
LNB Tone	22 KHz
DiSEqC	✓
SCR dCSS (EN 50494 EN 50607)	✓

Description of equipment components

Connectors and controls



- 1. Touch screen 8"
- 2. Connectors
- 3. Keyboard and LED indicators
- 4. Battery (on the back)

Keyboard

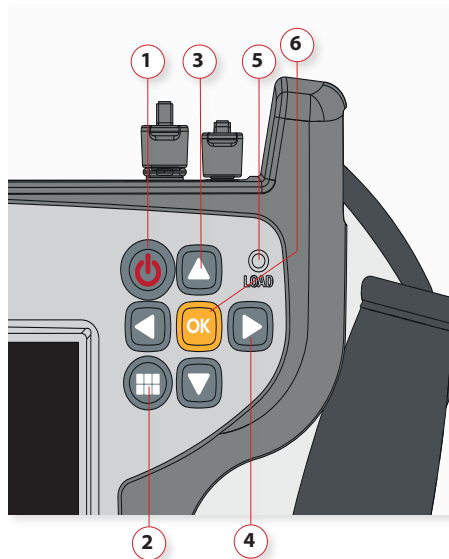

- 1. **Device ON/OFF button:** To turn the equipment off, press and hold for approximately 3 seconds. Short press to lock/unlock the screen.
- 2. **Menu button:** First press-features menu is shown. Second press-context menu is shown. Third press-all menus are hidden.
- 3. **Up/Down buttons:** Changes channel.
- 4. **Left/Right buttons:** Changes screen in multi-screen features.
- 5. **Powering LED:** Indicates if the equipment is powering an external load.
- 6. **OK button:** Short press to accept an option, and press and hold for more than 10 seconds to reset the device.

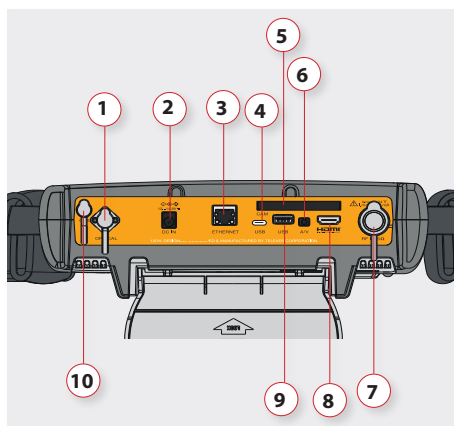

- 1. F.O.
- 2. Power connector
- 3. ETHERNET
- 4. USB-C (future use)
- 5. CAM
- 6. A/V
- 7. RF Input
- 8. HDMI
- 9. USB
- 10. GPS

CAUTION: the USB ports are only for data transmission, not for device charging

Power supply

A DC adapter is provided to power and charge the meter. Plug the adapter into a properly grounded electrical supply and the power connector on the side of the unit.

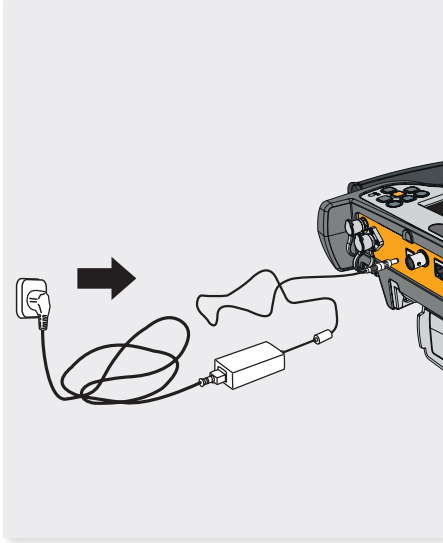

When external power is supplied, the battery management system automatically controls the charging process.

A battery icon indicates the charge status of the battery.

When the battery is fully charged, the battery icon is completely filled. As the battery discharges, the amount the icon is filled decreases in steps.

From a fully discharged state, a full charge takes approximately between 3 and 4 hours. And a 1 hour charge will provide battery for around two working hours.

The charge management system will detect various conditions preventing charging, such as a battery that is over a safe temperature.

About the battery

Important:

If the equipment is going to be stored for a while, it is recommended to take the battery off and store them both separately.

To maximize battery life:

- ▶ Allow fully discharging the battery.
- ▶ The battery can be charged correctly attached to the device and using the supplied DC adapter. Or separately using the DC adapter supplied with the MOSAIQ6.
- ▶ For long term storage, take the battery pack off, and keep the device and the battery pack separately at room temperature, or about 25° C. Start with a charged battery and re-charge the battery every 2 to 3 months.

Battery replacement:

It is recommended to use only the battery packs supplied by the manufacturer to replace the battery, following these instructions:

- ▶ Disconnect the meter from the power supply:

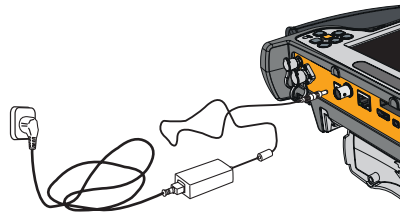

- ▶ Turn the MOSAIQ6 off:

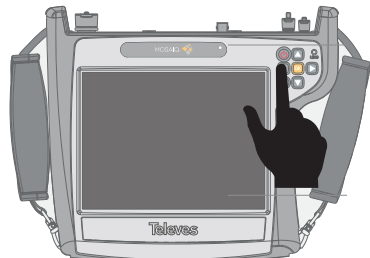

- The battery pack is placed in the bottom-back side

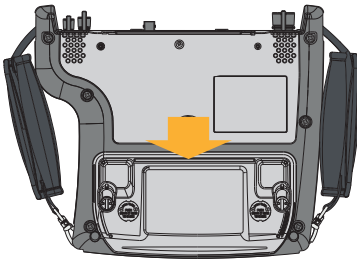

- Lift the fixings washers and rotate them 90°. You'll notice that the fixings get out automatically allowing to remove the battery pack

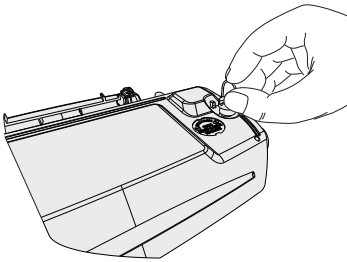

- Put the new battery pack and rotate the fixings washers again until the fixings fit into the device

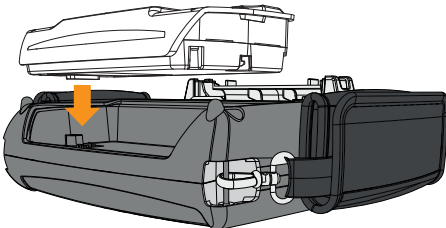

- Turn you MOSAIQ6 on

Important: never remove the battery as long as your meter is on

Separately battery charge

The battery can be charged separately from the meter using the DC adaptor supplied with the MOSAIQ6. Plug the adaptor into a properly grounded electrical supply and the power connector on the side of the unit.

The flashing light indicates that the battery is being charged.

If the battery charge is less than 30% the light is red.

If the battery charge is between 30% and 60% the light is yellow.

If the battery charge is greater than 60% the light is green.

Gestures

MOSAIQ6 has an innovative interface, exclusively designed to get the most out of its 8" multi-touch display.

To do this, MOSAIQ6 uses some gestural commands that are explained below:



Tap: one fast touch with one finger.



Double tap: two fast consecutive touches with one finger.



Swipe: short swipe with one finger.



Drag: drag with one finger.



Pinch/Spread: pinch/spread two fingers on the screen.



Drag and drop.

Before starting

The first time you turn your MOSAIQ6 on, please follow the next steps for a proper registration. To do that, you must be registered on the Televés website (www.televés.com).

In addition, you need internet connection (Ethernet or Wi-Fi). Then, please follow the next steps that will be shown on the screen :

1.- Choose the language



2.- Select the internet connection (Ethernet or Wi-Fi):

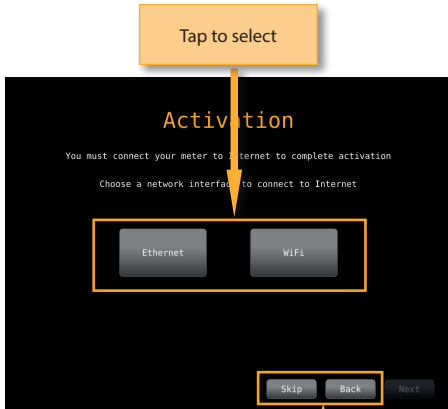

Skip: cancel the registration. If you skip, you will be prompted to register your meter each time you turn it on
Back: back to previous step
Next: goes to the next step

3.1- If you select Ethernet, all the parameters will appear on the screen: you can enable DHCP mode (the meter will select all the parameters automatically), or disable it (then you must enter all the network parameters)

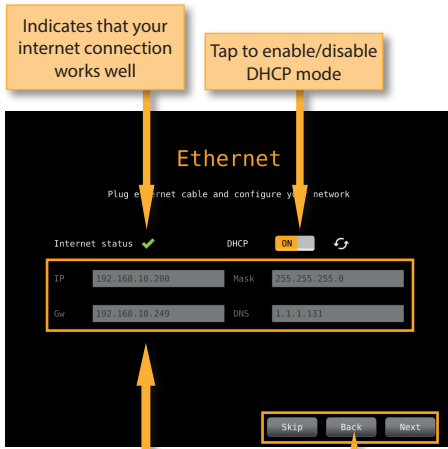

Skip: cancel the registration. If you skip, you will be prompted to register your meter each time you turn it on
Back: back to previous step

3.2- If you select Wi-Fi, a list with all the Wi-Fi networks will appear on the screen. You must select one of them to access the internet.

4- When your MOSAIQ6 is connected to the internet, you have to enter you Televés account data (e-mail and password).



Skip: cancel the registration. If you skip, you will be prompted to register your meter each time you turn it on
Back: back to previous step
Next: goes to the next step

5.- Your MOSAIQ6 is registered!:

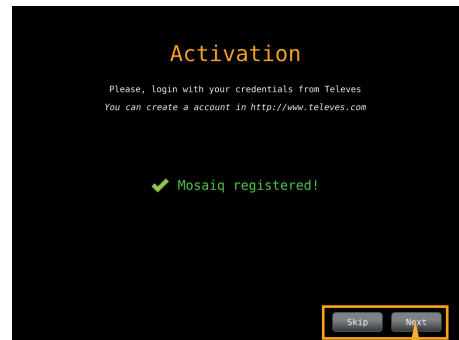

Skip: cancel the registration. If you skip, you will be prompted to register your meter each time you turn it on
Next: goes to the next step

6.- The last step is to enter an alias for your MOSAIQ6, this name will be saved in our database:

Enter an alias for your meter

Alia

Please, select an alias for this meter

Alias EQUIPO SANTIAGO

Skip Next

Skip: cancel the registration. If you skip, you will be prompted to register your meter each time you turn it on

Next: goes to the next step

Icons on the screen

There are always two bars on the screen : one on the top and one on the bottom. The icons in them will be explained bellow.

Bottom bar:

Tap to direct access to TV Analyser feature

Tap to save LOG/MacroLOG

Tap to change tuned Channel/frequency

Tap to change selected profile

Tap to change selected service

Tap to change Band

Tap to change channel-tuning frequency tuning

- Direct access to TV Analyser feature: see section 6.- *TV Analyser*.

- Change channel/frequency:

- If it is selected the **RF input** (see section *Top Menu->Inputs/Outputs*) allows you to select another channel (if it is selected channel tuning model) from the channel plan corresponding to the selected user profile (See section 2.- *User profiles*), or another frequency (if it is selected frequency tuning mode).

If it is selected the **channel tuning mode**, a pop-up window will show all the channels of the channel plan of the user profile (if you haven't do a scan -see section 6.1.- *Scan*-) or a list with the channels found after having made a scan and saved the plan. In the top right side of the channel list, you can see two icons: a pencil, if you tap on it, you can edit the channel list of channels (add or remove channels); and a bust, if you tap on it, the user profile window will be open (See section 2.- *User profiles*):

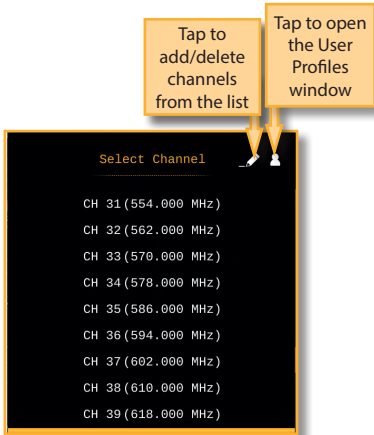

If it is selected the **frequency tuning mode**, allows you to change tuned frequency:

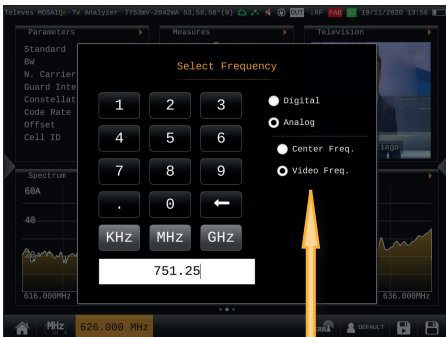

When terrestrial band is selected and the meter is in TV Analyser function, allows to select between video carrier freq. or central freq.

- If it is **selected the IP input**, this function allows you to select the IP channel, as well as to add /delete channels to the list. To do that, a pop up window will be shown with the list of the IPTV channels. The MOSAIQ6 has a default channel that you can edit:

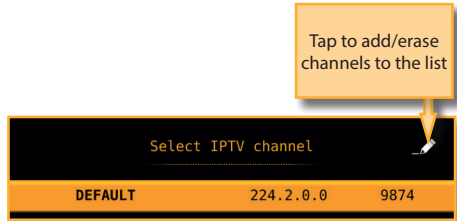

EN

To add a new IPTV channel, it is necessary to indicate the following parameters:

- Name
- IP: is the traffic IP (multicast or unicast)
- Origin IP: when the traffic is multicast and uses IGMP version 3, you could set the origin IP of the source. If you want to disable it, you must set the Origin IP to 0.0.0.0
- Port

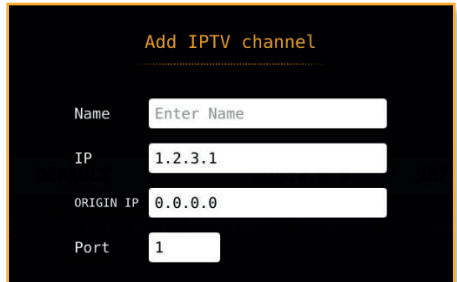

Note: See section *Web Application*->4.- *Plans* to learn how to create TV and IPTV channel plans using the web application

•Change selected service: it allows the user to select any other service locked previously. This feature shows a pop up window with all the services that the user has selected previously in any channel.

Tap on the star to bookmark your favorite services. The favourite services are always in the top of the list

Sort the list by name or by LCN

If the selected service is in a channel different from the tuned, the MOSAIQ6 will tune the new channel and select the service automatically

Delete a service from the list

•LOG/MacroLOG: allows to save a new LOG or MacroLOG. The following window will be shown:

Choose between LOG or MacroLOG

If new LOG is selected, Mosaiq6 saves the measurements and the screenshot at that moment. If new MacroLOG is selected, Mosaiq6 allows you to schedule repetitive measures in time intervals selected by the user. See section 9.- LOGs.

•Change band: see section 2.- *User profiles*

•Change profile: a pop-up window will show all the user profiles, allowing the user to select another profile. In the top right side of the profiles list, you can see a icon of a bust, if you tap on it, the user profile window will be open (See section 2.- *User profiles*)

Tap to open the User Profiles window

Top bar:

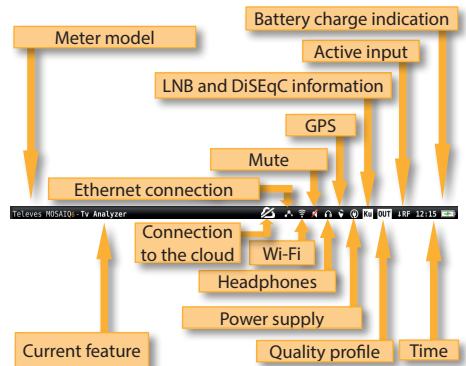

•Connection to the network: indicated that the meter is connected to the network by Ethernet. See section Settings-Network in *Top Muenu*
 - No icon->No cable connected

- *White icon*->Cable connected
- *Green icon*->Connected to the internet
- Wi-Fi: indicates that the meter is connected to a Wi-Fi network. See section *Settings-Wi-Fi* in *Top Menu*
 - *No icon*->Wi-Fi disabled
 - *White blinking icon*->Wi-Fi stablishing connection
 - *White icon*->Wi-Fi connected
 - *Grey icon*->Wi-Fi error
 - *Green icon*->Connected to the internet
- GPS: indicates that the GPS is active. While the satellite data is not received, the icon blinks. See section *Settings-GPS* in *Top menu*. To perform a Drive-Test the GPS must be active, and then schedule a MacroLOG (see icons in the Bottom bar). The results of the Drive Test are shown in the web application. See section *1.- Measurements in Web application*.
- LNB and DiSEqC information: shows information about the LNB band (only if real frequency is selected -see section *1.2.- Measurements* of the menu *1.- Settings*-), as well as about DiSEqC if it is active. See section *2.- User profiles*
- Quality profile: indicates the selected quality profile. To select another quality profile, access the *options context menu* of the feature. See section *Options context menu* in *Menus*. To add new quality profiles see section *5.- Quality profiles in Web application*.
- Enabled input: See section *Inputs/Outputs* in *Top menu*.
- Time: see section *Regional* in the feature *1.- Settings*
- Connection to the cloud: See section *Before Starting* to register you and your Mosaiq6, so you will access to the cloud.
 - *Crossed out icon*->No internet connection or cloud connection
 - *White icon*->There is connection to the cloud, but the Mosaiq6 is not registered
 - *Green icon*->Connected to the cloud and Mosaiq6 registered

Menus

The MOSAIQ6 has 3 different menus. These menus will be explained in this section briefly, as well as their locations. All their features will be explained in the sections below.

Top Menu



To access this menu you must do a short swipe in the top central part of the screen. The features of this menu allows us to set up certain aspects of the meter in a fast way and from any feature.

Main Menu



To access this menu you must do a short swipe in the right central part of the screen. The main menu is wheel with all the features of the meter. Doing long swipe on the wheel, the user can access every features. To select a feature, you must tap on the corresponding icon.

Options context menu



Most of the features of the main menu have a menu with some options that pertain exclusively to that feature. These options are in a context menu that appears when the user does short swipe in the left central part of the screen.

Top menu

This menu has several tabs that will be explained below. To select one of them, the user must tap on the title.

Inputs/Outputs:

Doing tap on the connector draw, the corresponding input/output will be enabled/disabled. Once it is enabled, the user must set some options depending on the kind of input.

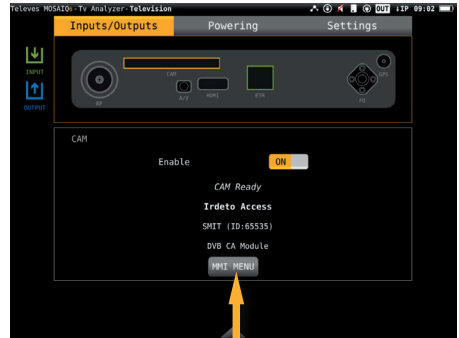
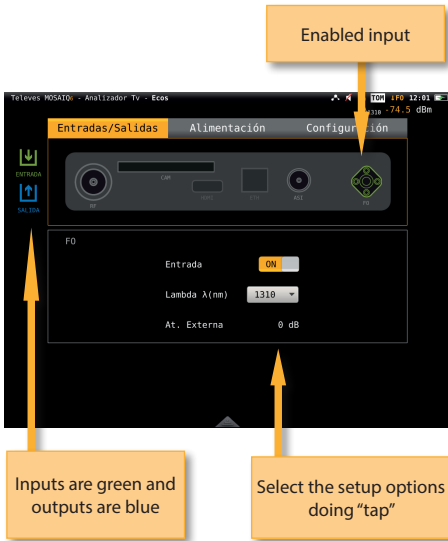

Below are shown all the inputs/outputs, as well as all their options:

- RF
 - Input: ON/OFF. Enables/disables the RF input
 - Field Strength: ON/OFF. If ON is selected, this measurement will be shown in the Measurements widget of the TV Analyser feature (see section 7.4.4.- Measurements)
 - Antenna: In order to calculate the field strength measurement, the user must select the antenna that he/she is using
 - External Amp/Att: if an amplifier or an attenuator is being used at the RF input of the MOSAIQ6, you can enter the value, so it will be taken into account when making the calculations of the power measurements
- CAM
 - Enable: Enables/disables the conditional-access module
If you select CAM input, please wait a few seconds until the MOSAIQ6 detects the CAM. Then you can access to the MMI menu of the CAM:

•A/V

- CVBS Input: Enables/disables the connector as a CVBS input
- Headphones Output: Enables/disables the connector as headphones output

•HDMI

- Output: Enables/disables the connector as a HDMI output
- Mode: OSD+Video/Video. Allows to choose what the user wants to get: only the video signal, or video + OSD

•ETH

- IPTV Input: ON/OFF. Enables/disables the Ethernet connector as an input for IPTV signals. Please see section *Icons in the screen->Bottom Bar* to learn how to create an IPTV channel

•FO

- Input: ON/OFF. Enables/disables the connector as an input for optical signals.
- Lambda λ (nm): 1310, 1490, 1550. Allows to select the wavelength of the input signal
- External Att: if an optical attenuator is being used at the optical input of the MOSAIQ6, you can enter the value, so it will be taken into account when making the calculations of the power measurements

•GPS

- Input: ON/OFF. Enables/disables the external GPS input

Powering:

Allows setup the preamplifiers powering.

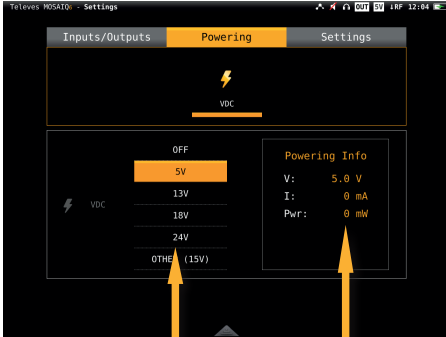

Select doing "tap"

Consumption information

•**Volume:** increases/decreases the volume



EN

Increases/Decreases doing "drag"

Settings:

The user can set the following parameter from this menu:

•**Brightness:** increase/decrease the display brightness

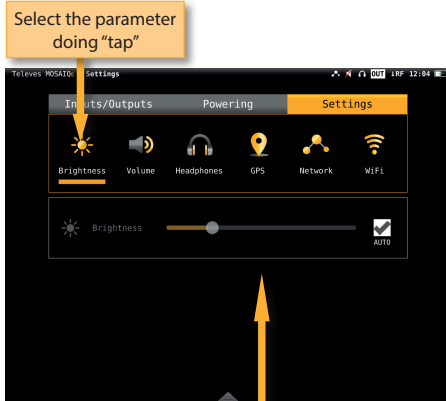

Increase/decrease doing "drag"

•**Touch:** increases/decreases the touch control sensitivity

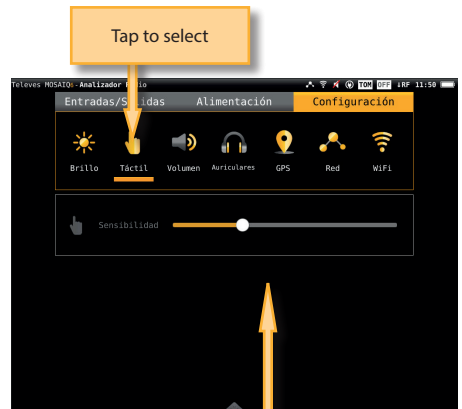

Drag to increase/decrease

•**Headphones:** enables/disables audio A/V output

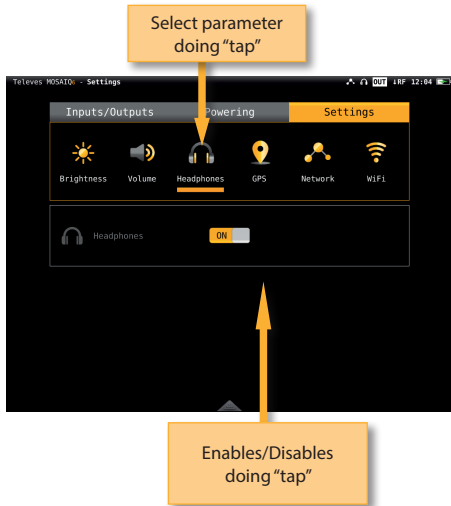

configures automatically. If the DHCP mode is off, the user must type all the network parameters (IP, Gateway, Mask and DNS), and the do tap in "Apply".

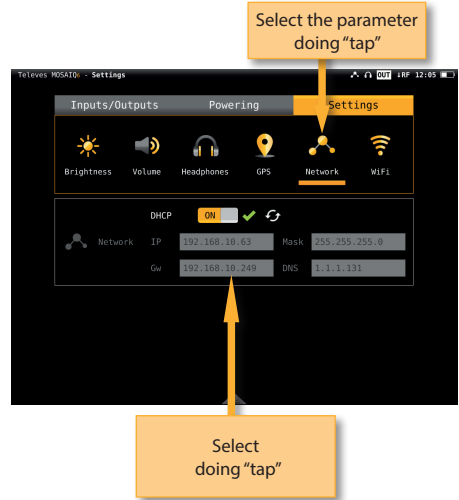

•**GPS:** Enables/disables the GPS feature. When it is enabled, the corresponding icon appears on the top bar of the screen. While the MOSAIQ6 does not receive the satellite signal, the GPS icon will blink.

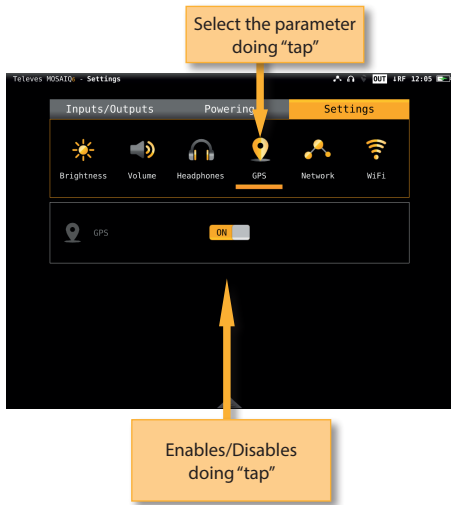

•**Wi-Fi:** enables/disables the equipment Wi-Fi connection.



•**Network:** Allows to set up the equipment network connection. If the user selects the DHCP mode (DHCP ON), the network parameters will be

Main menu

All the MOSAIQ6 features are contained in this menu, and they will be explained in the following sections.



1. Settings

Allows set all the global parameters of the meter. This feature has several tabs that will be explained below:

1.1.- Regional

Sets the language, the date and the time.

Check to display the date in the top bar

Dropdown the list doing "tap"

Check to get the network time

Select time zone

Tap to change date and time

The screenshot shows the 'Regional' settings tab with options for Language (English), Show Date (checkbox), Network Time (checkbox), Zone Time (Europe - Madrid), Date (11/11/19), and Time (13:35). Callouts point to the 'Show Date' checkbox, the 'Zone Time' dropdown, the 'Date' field, the 'Time' field, and the 'Network Time' checkbox.

1.2.- Measures

Allows to set up those parameter that are commons to all the measurements: units, frequency (if real frequency is nos checked, the meter will use IF) and LNB.

Both the measurements and the GPS coordinates will be shown in the units selected in this menu.

You can also select between Center or Video Carrier in the Analog Frequency dropdown list. So, when the meter is in TV Analyser function, terrestrial band, and in frequency mode, when the user enters a new frequency using the keyboard, it will correspond to the central frequency of the analog channel, or the video carrier frequency, according to the user's selection.

Dropdown tapping

Select/Deselect real frequency tapping

The screenshot shows the 'Measures' settings tab with dropdown menus for Units (dBuV), Optical Units (dBm), Analog Frequency (Video carrier), LNB (Universal), and GPS Units (degrees). A checkbox for 'Real Frequency' is also visible. Callouts point to the 'Analog Frequency' dropdown, the 'Real Frequency' checkbox, and the 'Units' dropdown.

1.3.- Energy

Allows set the energy-saving modes. Select the downtime until equipment auto suspension, and the downtime until auto shutdown.

Drag to select

Information about battery

The screenshot shows the 'Energy' settings tab with sliders for 'Auto suspension' (5min) and 'Auto shutdown' (10min). Below is a 'Battery Info' section showing State (Charging), Level (45%), Voltage (7.4V), Current (1.65A), V. Ext (11.8V), Temp (35.0°C), and Charg. (124mIn). Callouts point to the 'Auto suspension' slider and the 'Battery Info' section.

1.4.- Update

When the MOSAIQ6 is connected to the internet (via Ethernet or Wi-Fi) it is automatically detected if a new firmware version is available. If so, tap on the Update button and your MOSAIQ6 will be automatically updated.

Be aware that the meter must be connected to the external powering to be updated.

This menu allows to configure the synchronization between the MOSAIQ6 and the cloud (see section *MOSAIQ6 Cloud*)

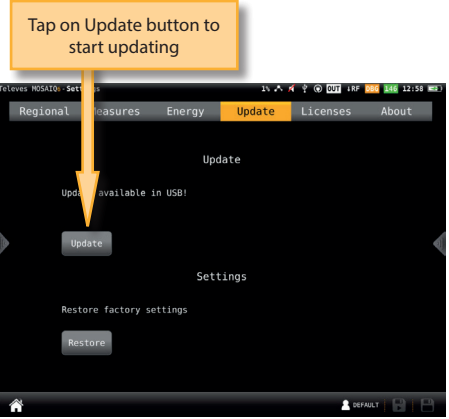

1.5.- Licenses

Shows a list with all the licenses of your MOSAIQ6.



1.6.- About

Shows all the information about your equipment, both hardware and software.

It is also possible to open the user manual and read it in the the MOSAIQ6 screen (only compatible HW)

You can also update your device using an USB stick. To do that, save the update file in an USB stick and insert the USB stick into the USB connector of your MOSAIQ6. A message appears automatically indicating that an update is available on the USB. When you go to the Update menu, the following screen will appear:

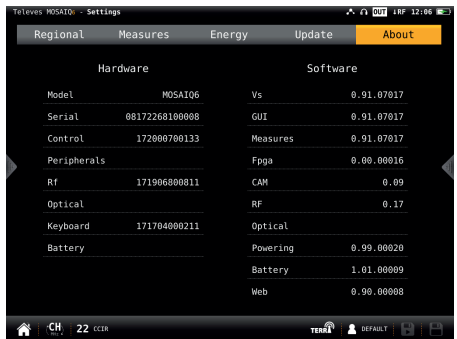



2. User Manual

This function displays the user manual on the Mosaiq6 screen.

This functionality is available only for Mosaiq6 with compatible hardware.

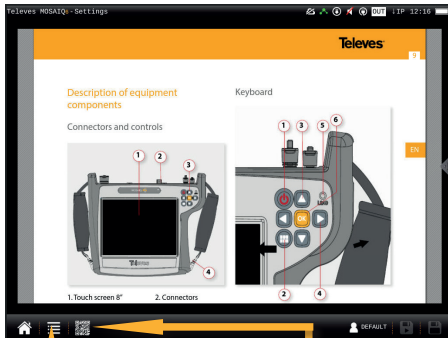

Shows the manual index

Shows the QR code with the link to the manual on our website



3. User profiles

Your **MOSAIQ6** allows to define as many user profiles as you need. For each user profile, you must indicate what band(s) is going to measure that user profile and the main parameters.

If you select terrestrial band for a profile, you must select the channel plan, the preamplifiers powering and the norm.

If you select satellite band for a profile, you must select the channel plan, polarity, powering, SCR and DISEqC.

If you select the radio band, you must select the DAB channel plan.



EN

3.1.- Set

Goes to the setting feature of the main menu (see section 1.- Settings)

3.2.- Add

Adds a new user profile. When you tap on this button, a popup window will open where the user must set all the required parameters.

First of all, you must type the profile's name. Then you must select the bands you want to include in that profile and set up the parameters.

To select a band, you must select the corresponding check box. The first step is the terrestrial band, then tap on "Next" button pass to the satellite band, and finally the radio band.

Once you have finished the radio band configuration, tap on "add" button to save the user profile.



If you include the satellite band in the profile, you must select how many satellites you want to include in that profile. Then you must set all the parameters for each one.

Each satellite plan is automatically associated with a DiSEqC command (first plan with SAT A, second plan with SAT B, and so on). So, the powering is always ON and automatically set to AUTO, but the user can select any other value.

3.3.- Edit

Allows changes in the selected profile of the list. The process is similar to add a new profile.

3.4.- Delete

Deletes the selected profile from the list.



4. Optical attenuation

This feature allows to measure the optical attenuation in the fibre network in three wavelengths: 1310nm, 1490nm and 1550nm. When the user selects this features, the optical fibre input is automatically enabled. Please, see section Top Menu->Inputs/Outputs to learn how to enable the optical input.

- Calibrate: select the wavelength (tap on the graphic or on the list) and tap on this button to calibrate it.

- Units: mW/ μ W, dBm.

- Auto lambda (OPS3L): OFF/ON. If ON is selected, the MOSAIQ6 synchronizes with the Televes OPS3L light source, whenever it is in auto lambda mode too, so the MOSAIQ6 gets the measurements over the three lambdas simultaneously.

EN

4.1.- Main window:

Bar graph that represents the attenuation of each wavelength

Enabled O.F. input icon

List with the measurements in each wavelength: attenuation, power and reference
Tap to select

4.2.- Options context menu:



5. Satellite identification

This feature is able to detect automatically the satellite the input signal belongs to.

5.1.- Main window

The Mosaic6 adjusts automatically all the parameters of the spectrum

Once the satellite is identified, the name is shown in the display

5.2.- Options context menu

•Powering:

- VDC: Selects the preamplifier powering.
- DiSEqC (only satellite band): selects the DiSEqC parameter (Sat A, Sat B, Sat C, Sat D).

- Positioner (only satellite band): makes it possible to control the DiSEqC motors used to move mobile parabolic antennas. This function is available in satellite mode and when the equipment is powering the LNB.

Halt: This command stops the motor movement.

East: Allows to move the motor in the EAST direction. Each click corresponds to one step in the movement of the motor (pitch motors). By holding the key down, successive movement sequences will be executed until the key is released.

West: Motor movement in the WEST direction. Each click corresponds to one step in the movement of the motor (pitch motors). By holding the key down, successive movement sequences will be executed until the key is released.

Store: 8 storage positions are available to store at up to 8 antenna positions. This command allows one of 8 positions to be chosen where the current position of the antenna will be stored.

Goto: recovers one of the 8 positions for the antenna that has been previously stored

- SCR (only satellite band): Selects the SCR parameters (multiswitch, standard and slots) When a slot is enabled (for example slot 3, freq. 1210MHz), the meter will tune into the slot frequency (1210MHz) and will set the slot with the meter parameters: frequency, band (powering), and DiSEqC. In addition, a SCR icon will be shown in the bar at the top (SCR3) to indicate that the slot is enabled. While the slot is enabled, all the setting changes of the meter, will be applied to the currently slot (SCR3).

•Aim antenna:

Emits a modular audible signal. This is a useful feature to point antennas without having to look at the display



6. LTE check

The presence of signals in 4G and 5G bands in distribution systems DTT, can affect the quality of the TV signal.

This function makes an analysis of the 4G and 5G signals and its influence on digital terrestrial television signal (UHF band), and it also estimates the need to insert a filter at the input of a Digital Terrestrial Television (DTT) system, in order to minimize interferences that may cause the signal on the DTT signal.

When you select this function, only the 4G Downlink and the 4G Uplink bands are analysed. You must display the Options Context Menu to analyse the 5G band.

6.1.- Main window

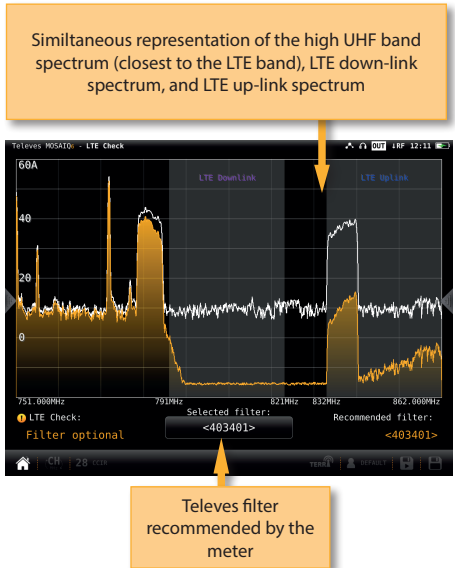

On the screen are displayed simultaneously: 1- The spectrum of the high "UHF" band (closest to the LTE band); 2- The spectrum of the LTE down-link; 3- And the spectrum of the LTE up-link.

In addition to the recommended filter, you can select various filters Televes LTE and display the simulation of how the system would respond with a LTE filter inserted on its input (orange graphic). Use the rotary selector to choice each one of the available filters.

The selected filter is displayed in the bottom center of the screen, there is also the option of not selecting a filter.

6.2.- Options context menu



•4G+5G: ON/OFF. When ON is selected, the function analyses the 4G up and down links, as well as the 5G up and down links, detecting possible interfering signals and, if it is necessary it recommends a filter.

•Powering: Selects the preamplifier powering.

If it is necessary to insert a filter, is indicated on the screen.

If it was not necessary to insert a filter, it will be displayed the text "LTE Check OK" instead of "Required LTE filter".



7. TV Analyser

This is the main function of the **MOSAIQ6**. The user can reach this function by tapping the icon .

Please, see section *Top menu->Inputs/Outputs* to learn how to select the input that you want to use, and the section *Icons in the screen->Botton bar* to learn how to change the selected channel, and how to add channels for IPTV.

Thanks to this feature it is possible to have in one screen all the information of the tuned signal. The feature TV Analyser has 3 screens: Scan, Mosaïq 3+1 & Mosaïq 6. To switch between screens do long swipe.



Bellow there is a detailed explanation of each of these screens:

7.1.- Scan

This function scans the selected channel plan and detects every existing analog and digital channel in real time to determine the overall frequency response of the system.

The scan measurement leverages the location based thresholds to clearly show whether or not signal levels comply with the cable system's specifications with their green, yellow and red bars.

7.1.1.- Main window

Bar graph representing all the found channels

Banda Tap to select

Tap to access to the learning plan menu

Signal spectrum

List with channels and measurements

CH	Freq.(MHz)	Type	Pwr.(dBm)	C/N.(dB)	MER.(dB)	CBBER	LM
36	594.000		-107.0	<1.0			
37	602.000		-107.0	<1.0			
38	610.000		-107.0	<1.0			
39	618.000		-107.0	<1.0			
40	626.000		-107.0	<1.0			

Tapping on the icon  a popup window will appear showing the following functions:

Selected channel Change tapping on the bar graph or on the channel table

Band Tap to select

Channel table with found channels Vertical drag to see them all

Options buttons (tap)

Bar graph with the channels found in the last scan

CH	Freq.(MHz)	Type	Pwr.(dBm)	C/N.(dB)	MER.(dB)	CBBER	LM
22	682.000	DIGITAL	55.3	43.5			
23	690.000	DIGITAL					
24	698.000	DIGITAL					
26	714.000	DIGITAL					
28	730.000	DIGITAL					
30	738.000	DIGITAL					
40	786.000	DIGITAL					
42	642.000	DIGITAL					
45	666.000	DIGITAL					
48	690.000	DIGITAL					
53	730.000	DIGITAL					
56	754.000	DIGITAL					
59	778.000	DIGITAL					
60	786.000	DIGITAL					

- Start: Starts a new system scan
 - Options:
 - Fast: ON/OFF. When the fast scan is enabled (ON), the meter will not make CBER and VBER measurements for digital channels, neither V/A measurements for analog channels. So, only power and level measurements will be shown.
 - Wide outlet: ON/OFF. Enable this option when the outlet in your installation has both terrestrial and satellite bands. So, both bands will be scanned consecutively. If this options is disabled, only the selected band will be scanned.
- Note:** Note that if the selected user profile does not allow to make measurements in some bands, the scan will not be done in that band.
- Edit: Allows to add/delete channels from the plan. If the channel is selected (orange coloured), when you tap on it, it will be deselected. Otherwise, if the channel is unselected (grey coloured), when you tap on it, it will be selected.
 - Save: Saves a new plan with the found channels.
 - Cancel: Closes the options window.

7.1.2.- Options context menu

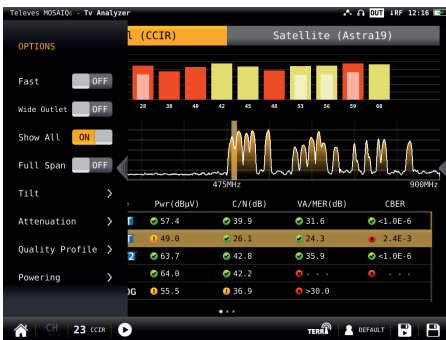

- Fast: ON/OFF. When the fast scan is enabled (ON), the meter will not make CBER and VBER measurements for digital channels, neither V/A measurements for analog channels. So, only power and level measurements will be shown.

- Wide outlet: ON/OFF. Enable this option when the outlet in your installation has both terrestrial and satellite bands. So, both bands will be scanned consecutively. If this options is disabled, only the selected band will be scanned.

Note: Note that if the selected user profile does not allow to make measurements in some bands, the scan will not be done in that band.

- Show all: ON/OFF. When show all is ON, all the measurements of all the channels are shown. When it is OFF, you can only see the measurements of the channel that is being measured in that moment.
- Span full: ON/OFF. When Span full ins ON you can see all the bars corresponding to all the found channels. When this option is OFF, only 24 bars are shown, so it is necessary to scroll to see them all.
- Tilt: ON/OFF. When the tilt option is ON, this function measures the tilt between the channels indicated in the labels CH A and CH B. Then you can see a white line between these two channels and the tilt measurement on it.

- Attenuation: ON/OFF. When the attenuation option is ON, the MOSAIQ6 measures the attenuation of the installation relative to a reference point, usually the head-end output. So, the first thing you must do is connect the meter to the reference point and tap on the Calibrate button. In this way, the equipment will measure and save the level of all the channels.

Then you must go to all the pints of the installation where we want to measure and connect the meter, taking care to have this function ON. The MOSAIQ6 will measure the levels of all the channels comparing them with the reference ones.

When this option is ON, the bars of the graphic don't represent the level or the power of the channels, but the attenuation of each one of them. The list shows power (or level) and C/N. In addition, a green trace is shown in the spectrum. This trace indicates the levels in the reference point.

- Quality profile: allows to select the quality profile .
- Powering:
 - VDC: Selects the preamplifier powering.

- DiSEqC (only satellite band): selects the DiSEqC parameter (Sat A, Sat B, Sat C, Sat D).
- Positioner (only satellite band): makes it possible to control the DiSEqC motors used to move mobile parabolic antennas. This function is available in satellite mode and when the equipment is powering the LNB.

Halt: This command stops the motor movement.

East: Allows to move the motor in the EAST direction. Each click corresponds to one step in the movement of the motor (pitch motors). By holding the key down, successive movement sequences will be executed until the key is released.

West: Motor movement in the WEST direction. Each click corresponds to one step in the movement of the motor (pitch motors). By holding the key down, successive movement sequences will be executed until the key is released.

Store: 8 storage positions are available to store at up to 8 antenna positions. This command allows one of 8 positions to be chosen where the current position of the antenna will be stored.

Goto: recovers one of the 8 positions for the antenna that has been previously stored

- SCR (only satellite band): Selects the SCR parameters (multiswitch, standard and slots) When a slot is enabled (for example slot 3, freq. 1210MHz), the meter will tune into the slot frequency (1210MHz) and will set the slot with the meter parameters: frequency, band (powering), and DiSEqC. In addition, a SCR icon will be shown in the bar at the top (SCR3) to indicate that the slot is enabled. While the slot is enabled, all the setting changes of the meter, will be applied to the currently slot (SCR3).

7.2.- Mosaic 3+1

This screen has 4 widgets, 3 in the top of the screen and one in the lower part of the screen. These widgets are user-configurable, that is, the user can select the the function he or she wants to visualize in each widget.

7.2.1.- Main window

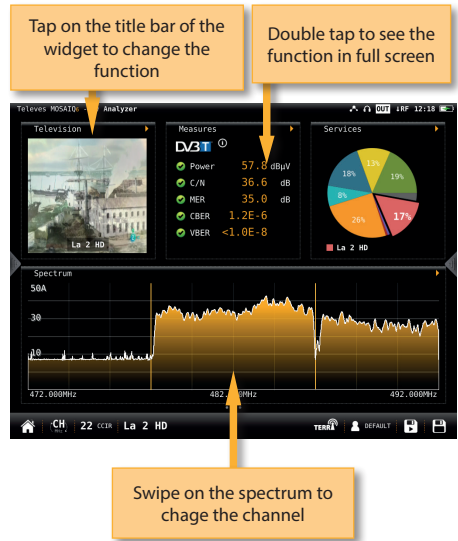

All the available features are explained in section 7.4.- Features.

7.2.2.- Options context menu:



- Quality profile: allows to select the quality profile
- Powering:
 - VDC: Selects the preamplifier powering.
 - DiSEqC (only satellite band): selects the DiSEqC parameter (Sat A, Sat B, Sat C, Sat D).
 - Positioner (only satellite band): makes it possible to control the DiSEqC motors used

to move mobile parabolic antennas. This function is available in satellite mode and when the equipment is powering the LNB.

Halt: This command stops the motor movement.

East: Allows to move the motor in the EAST direction. Each click corresponds to one step in the movement of the motor (pitch motors). By holding the key down, successive movement sequences will be executed until the key is released.

West: Motor movement in the WEST direction. Each click corresponds to one step in the movement of the motor (pitch motors). By holding the key down, successive movement sequences will be executed until the key is released.

Store: 8 storage positions are available to store at up to 8 antenna positions. This command allows one of 8 positions to be chosen where the current position of the antenna will be stored.

Goto: recovers one of the 8 positions for the antenna that has been previously stored.

- **SCR (only satellite band):** Selects the SCR parameters (multiswitch, standard and slots) When a slot is enabled (for example slot 3, freq. 1210MHz), the meter will tune into the slot frequency (1210MHz) and will set the slot with the meter parameters: frequency, band (powering), and DiSeqC. In addition, a SCR icon will be shown in the bar at the top (SCR3) to indicate that the slot is enabled. While the slot is enabled, all the setting changes of the meter, will be applied to the currently slot (SCR3).

7.3.- Mosaik 6

This screen has 6 widgets. These widgets are user-configurable, that is, the user can select the function he or she wants to visualize in each widget.

7.3.1.- Main window

Tap on the title bar of the widget to change the function

Double tap to see the function in full screen

Swipe on the spectrum to change the channel

All the available features are explained in section 7.4.- Features.

7.3.2.- Options context menu

Quality Profile >

Powering >

- Quality profile: allows to select the quality profile
- Powering:
 - VDC: Selects the preamplifier powering.

- DiSEqC (only satellite band): selects the DiSEqC parameter (Sat A, Sat B, Sat C, Sat D).
- Positioner (only satellite band): makes it possible to control the DiSEqC motors used to move mobile parabolic antennas. This function is available in satellite mode and when the equipment is powering the LNB.

Halt: This command stops the motor movement.

East: Allows to move the motor in the EAST direction. Each click corresponds to one step in the movement of the motor (pitch motors). By holding the key down, successive movement sequences will be executed until the key is released.

West: Motor movement in the WEST direction. Each click corresponds to one step in the movement of the motor (pitch motors). By holding the key down, successive movement sequences will be executed until the key is released.

Store: 8 storage positions are available to store at up to 8 antenna positions. This command allows one of 8 positions to be chosen where the current position of the antenna will be stored.

Goto: recovers one of the 8 positions for the antenna that has been previously stored

- SCR (only satellite band): Selects the SCR parameters (multiswitch, standard and slots) When a slot is enabled (for example slot 3, freq. 1210MHz), the meter will tune into the slot frequency (1210MHz) and will set the slot with the meter parameters: frequency, band (powering), and DiSEqC. In addition, a SCR icon will be shown in the bar at the top (SCR3) to indicate that the slot is enabled. While the slot is enabled, all the setting changes of the meter, will be applied to the currently slot (SCR3).

and Services features will be available.

7.4.1.- Television

This feature allows to visualize the selected service's image of the tuned channel.

Note: When the image is not available, one of these icons will be shown:

- Only audio service 🎵
- Encrypted channel 🔒
- Data service 📄

7.4.1.1.- Main window

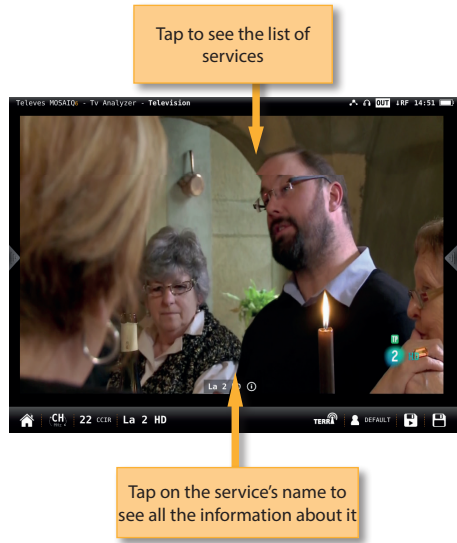

7.4.- Features

This section explains all the features available to visualize in the widgets of the Mosaiq 3+1 and Mosaiq 6 modes.

Note: If the ASI input is selected, only Television

Tapping on the screen, it appears a popup window with the list of the channel's services:



Tap on the service to select it

Next to the name of the service, the icons indicating the transports are shown (image, one or more audio transports). To change the audio, tap again on the screen and select the same service in the list, then a new pop-up window will appear showing the available audios.

Tapping on the service's name, it appears a popup window with the information about it:

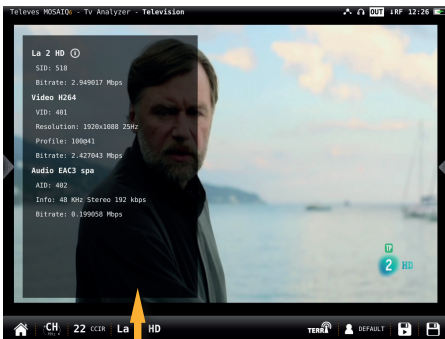

Tap to close the popup window

7.4.1.2.- Options context menu



•Quality profile: allows to select the quality profile

•Powering:

- VDC: Selects the preamplifier powering.
- DiSEqC (only satellite band): selects the DiSEqC parameter (Sat A, Sat B, Sat C, Sat D).
- Positioner (only satellite band): makes it possible to control the DiSEqC motors used to move mobile parabolic antennas. This function is available in satellite mode and when the equipment is powering the LNB.

Halt: This command stops the motor movement.

East: Allows to move the motor in the EAST direction. Each click corresponds to one step in the movement of the motor (pitch motors). By holding the key down, successive movement sequences will be executed until the key is released.

West: Motor movement in the WEST direction. Each click corresponds to one step in the movement of the motor (pitch motors). By holding the key down, successive movement sequences will be executed until the key is released.

Store: 8 storage positions are available to store at up to 8 antenna positions. This command allows one of 8 positions to be chosen where the current position of the antenna will be stored.

Goto: recovers one of the 8 positions for the antenna that has been previously stored

- SCR (only satellite band): Selects the SCR parameters (multiswitch, standard and slots) When a slot is enabled (for example slot 3, freq. 1210MHz), the meter will tune into the slot frequency (1210MHz) and will set the slot with the meter parameters: frequency, band (powering), and DiSEqC. In addition, a SCR icon will be shown in the bar at the top (SCR3) to indicate that the slot is enabled. While the slot is enabled, all the setting changes of the meter, will be applied to the currently slot (SCR3).

7.4.2.- Services

This feature shows a graph with the distribution of the services of the channel. Tapping on one of the sections of the graph, you can see the name of the corresponding service.

If you see this feature in full screen, you will have more detailed information.

7.4.2.1.- Main window

List of services with ID, the LCN (for DVB channels) or the Virtual Channel (for ISDB-T channels), the service name, and bitrates. The color of the squares corresponds to the color of the section in the graph

Graph with the distribution of the channels services

Distribution and bitrates of the service PIDs

Service PIDs. The colors of the squares indicate the PID type

7.4.2.2.- Options context menu

•Quality profile: allows to select the quality profile

•Powering:

- VDC: Selects the preamplifier powering.
- DiSEqC (only satellite band): selects the DiSEqC parameter (Sat A, Sat B, Sat C, Sat D).
- Positioner (only satellite band): makes it possible to control the DiSEqC motors used to move mobile parabolic antennas. This function is available in satellite mode and when the equipment is powering the LNB.

Hold: This command stops the motor movement.

East: Allows to move the motor in the EAST direction. Each click corresponds to one step in the movement of the motor (pitch motors). By holding the key down, successive movement sequences will be executed until the key is released.

West: Motor movement in the WEST direction. Each click corresponds to one step in the movement of the motor (pitch motors). By holding the key down, successive movement sequences will be executed until the key is released.

Store: 8 storage positions are available to store at up to 8 antenna positions . This command allows one of 8 positions to be chosen where the current position of the antenna will be stored.

Goto: recovers one of the 8 positions for

the antenna that has been previously stored.

- SCR (only satellite band): Selects the SCR parameters (multiswitch, standard and slots) When a slot is enabled (for example slot 3, freq. 1210MHz), the meter will tune into the slot frequency (1210MHz) and will set the slot with the meter parameters: frequency, band (powering), and DiSEqC. In addition, a SCR icon will be shown in the bar at the top (SCR3) to indicate that the slot is enabled. While the slot is enabled, all the setting changes of the meter, will be applied to the currently slot (SCR3).

7.4.3.-Parameters

This feature shows the parameters of the locked signal.

7.4.3.1.- Main Window

Tap on the pencil to edit the standard, the BW, and the PLS n or root

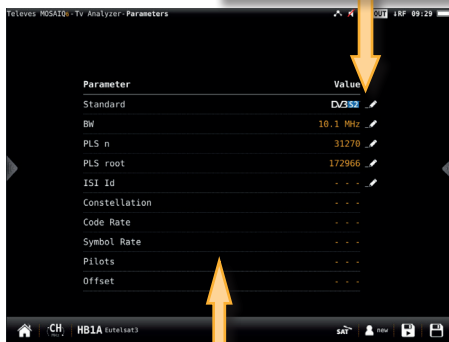

List of parameters

7.4.3.2.- Options context menu



•Powering:

- VDC: Selects the preamplifier powering.
- DiSEqC (only satellite band): selects the DiSEqC parameter (Sat A, Sat B, Sat C, Sat D)
- Positioner (only satellite band): makes it possible to control the DiSEqC motors used to move mobile parabolic antennas. This function is available in satellite mode and when the equipment is powering the LNB.

Halt: This command stops the motor movement.

East: Allows to move the motor in the EAST direction. Each click corresponds to one step in the movement of the motor (pitch motors). By holding the key down, successive movement sequences will be executed until the key is released.

West: Motor movement in the WEST direction. Each click corresponds to one step in the movement of the motor (pitch motors). By holding the key down, successive movement sequences will be executed until the key is released.

Store: 8 storage positions are available to store at up to 8 antenna positions. This command allows one of 8 positions to be chosen where the current position of the antenna will be stored.

Goto: recovers one of the 8 positions for the antenna that has been previously stored

- SCR (only satellite band): Selects the SCR parameters (multiswitch, standard and slots) When a slot is enabled (for example slot 3, freq. 1210MHz), the meter will tune into the slot frequency (1210MHz) and will set the slot with the meter parameters: frequency, band (powering), and DiSeqC. In addition, a SCR icon will be shown in the bar at the top (SCR3) to indicate that the slot is enabled. While the slot is enabled, all the setting changes of the meter, will be applied to the currently slot (SCR3).

7.4.4.2.- Options context menu



7.4.4.- Measurements (RF input)

This feature shows the measurements of the selected channel. The measurements depends on the signal modulation:

- DVB-S: Power, C/N, MER, CBER, VBBER
- DVB-S2: Power, C/N, MER, LDPCBER, BCHBER
- DVB-T: Power, C/N, MER, CBER, VBBER
- DVB-T2: Power, C/N, Link Margin, LDPCBER, BCHBER
- DVB-C: Power, C/N, CBER, MER
- Analog: Level, C/N, V/A, HUM, CTB, CSO

If you see this feature in full screen, you will have more detailed information.

- Clear: restarts the graph.
- Last: 5 min, ½ hour, ½ day, 1 day, 1 week. Allows select the time interval shown in the graph
- Quality profile: allows to select the quality profile
- Powering:
 - VDC: Selects the preamplifier powering.
 - DiSeqC (only satellite band): selects the DiSeqC parameter (Sat A, Sat B, Sat C, Sat D).
 - Positioner (only satellite band): makes it possible to control the DiSeqC motors used to move mobile parabolic antennas. This function is available in satellite mode and when the equipment is powering the LNB.

Halt: This command stops the motor movement.

East: Allows to move the motor in the EAST direction. Each click corresponds to one step in the movement of the motor (pitch motors). By holding the key down, successive movement sequences will be executed until the key is released.

West: Motor movement in the WEST direction. Each click corresponds to one step in the movement of the motor (pitch motors). By holding the key down, successive movement sequences will be executed until the key is released.

Store: 8 storage positions are available to store at up to 8 antenna positions . This command allows one of 8 positions to be chosen where the current position of the antenna will be stored.

Goto: recovers one of the 8 positions for

7.4.4.1.- Main window

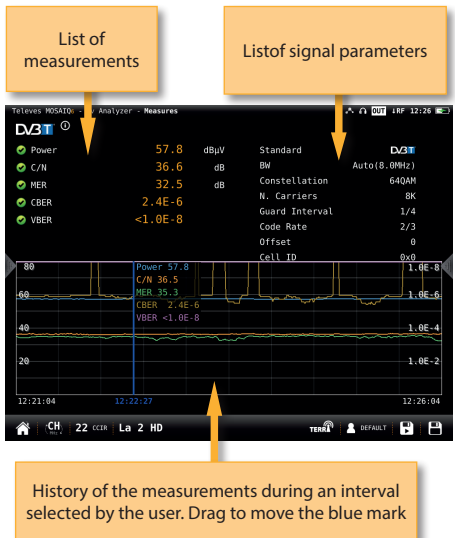

History of the measurements during an interval selected by the user. Drag to move the blue mark

the antenna that has been previously stored

- SCR (only satellite band): Selects the SCR parameters (multiswitch, standard and slots) When a slot is enabled (for example slot 3, freq. 1210MHz), the meter will tune into the slot frequency (1210MHz) and will set the slot with the meter parameters: frequency, band (powering), and DiSEqC. In addition, a SCR icon will be shown in the bar at the top (SCR3) to indicate that the slot is enabled. While the slot is enabled, all the setting changes of the meter, will be applied to the currently slot (SCR3).
- CTB (only analog channels): Turns ON/OFF the CTB measurement. If you select CTB ON, a popup window will be displayed asking you to turn the signal off. CTB can only be made with the service disabled, because it is a measurement made in the frequency of the video carrier of the TV signal. Turn the signal ON again to measure CTB and all other measurements properly.
- CSO Offsets (only analog channels): The CSO measure is carried out in different frequencies (at different distances from the video carrier) within the selected channel. Using this menu you can select the offset where you want to measure the CSO, and you can save up to 6 offset values, that can be the default values or user-selected ones.

7.4.5.- Spectrum (RF Input)

This feature shows the spectrum of the signal.

7.4.5.1.-Main window

Swipe to tune next/previous channel
Drag to tune any channel
Spread/Pinch to change span

Spectrum parameters

Power or C/N measurement.
Tap to change

Tap to enable/disable marks

The screenshot shows a spectrum plot with a power level of 77.8 dBuV. The interface includes a top bar with '50A', 'TV Analyzer - Spectrum', and '12:28'. The plot shows a signal between 472.000MHz and 492.000MHz. A 'MARKS' button is visible at the bottom right.

EN

If you tap to enable marks:

Drag to move the active mark

Tap to activate a mark
+ adds a new mark (max. 6).
- removes the active mark

Delta: measures the level difference between two marks

The screenshot shows the spectrum plot with three active marks at 482.287 MHz (34.2 dBuV), 485.285 MHz (8.3 dBuV), and 488.920 MHz (26.8 dBuV). The 'Delta' measurement between the first and second marks is -7.0 MHz and -27.2 dB. The 'C/N' measurement is 36.9 dB. The interface includes a top bar with '50A', 'TV Analyzer - Spectrum', and '12:29'. The plot shows a signal between 472.000MHz and 492.000MHz. A 'MARKS' button is visible at the bottom right.

7.4.5.2.- Options context menu



- Span: 100KHz, 1MHz, 5MHz, 10 MHz, 20 MHz, 50 MHz, 100 MHz, 200 MHz, 500 MHz, 1.0GHz, 2.0GHz, 3.3GHz, Other.
- Start Frequency: Allows the user to set the initial frequency of the spectrum graph.
- Stop Frequency: Allows the user to set the final frequency of the spectrum graph. Reference level: Auto, 50dBµV – 130dBµV
- RBW: 500 HzW – 5MHzW
- VBW: 100Hz – 1MHz
- Advanced: Access to spectrum advanced features:
 - Hold: enables/disables max. hold & min. hold features. Tapping on Clear button to restart hold trace.
 - Trigger: enables/disables the trigger by level feature. To select the level, tap on the label and a popup keyboard appears.
 - Fill: enables/disables the spectrum graph filled.
- Quality profile: allows to select the quality profile
- Powering:
 - VDC: Selects the preamplifier powering.
 - DiSEqC (only satellite band): selects the DiSEqC parameter (Sat A, Sat B, Sat C, Sat D).
 - Positioner (only satellite band): makes it possible to control the DiSEqC motors used to move mobile parabolic antennas. This function is available in satellite mode and when the equipment is powering the

LNB.

Halt: This command stops the motor movement.

East: Allows to move the motor in the EAST direction. Each click corresponds to one step in the movement of the motor (pitch motors). By holding the key down, successive movement sequences will be executed until the key is released.

West: Motor movement in the WEST direction. Each click corresponds to one step in the movement of the motor (pitch motors). By holding the key down, successive movement sequences will be executed until the key is released.

Store: 8 storage positions are available to store at up to 8 antenna positions . This command allows one of 8 positions to be chosen where the current position of the antenna will be stored.

Goto: recovers one of the 8 positions for the antenna that has been previously stored

SCR (only satellite band): Selects the SCR parameters (multiswitch, standard and slots) When a slot is enabled (for example slot 3, freq. 1210MHz), the meter will tune into the slot frequency (1210MHz) and will set the slot with the meter parameters: frequency, band (powering), and DiSEqC. In addition, a SCR icon will be shown in the bar at the top (SCR3) to indicate that the slot is enabled. While the slot is enabled, all the setting changes of the meter, will be applied to the currently slot (SCR3).

•Aim antenna:

Emits a modular audible signal. This is a useful feature to point antennas without having to look at the display

•Relative Marks: ON/OFF

If ON is selected, the marks will be relative to their position in the grid, not to their frequency

7.4.6.- Constellation (RF Input)

This feature shows the constellation diagram of the tuned channel.

7.4.6.1.- Main window

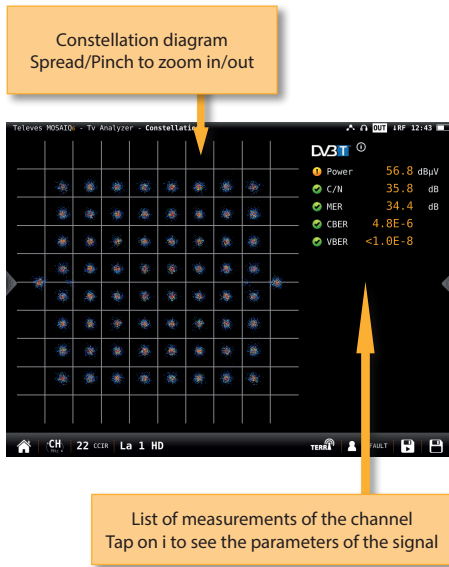

whose constellation must be displayed.

- Quality profile: allows to select the quality profile
- Powering:

- VDC: Selects the preamplifier powering.
- DiSEqC (only satellite band): selects the DiSEqC parameter (Sat A, Sat B, Sat C, Sat D).
- Positioner (only satellite band): makes it possible to control the DiSEqC motors used to move mobile parabolic antennas. This function is available in satellite mode and when the equipment is powering the LNB.

Halt: This command stops the motor movement.

East: Allows to move the motor in the EAST direction. Each click corresponds to one step in the movement of the motor (pitch motors). By holding the key down, successive movement sequences will be executed until the key is released.

West: Motor movement in the WEST direction. Each click corresponds to one step in the movement of the motor (pitch motors). By holding the key down, successive movement sequences will be executed until the key is released.

Store: 8 storage positions are available to store at up to 8 antenna positions . This command allows one of 8 positions to be chosen where the current position of the antenna will be stored.

Goto: recovers one of the 8 positions for the antenna that has been previously stored

-SCR (only satellite band): Selects the SCR parameters (multiswitch, standard and slots) When a slot is enabled (for example slot 3, freq. 1210MHz), the meter will tune into the slot frequency (1210MHz) and will set the slot with the meter parameters: frequency, band (powering), and DiSEqC. In addition, a SCR icon will be shown in the bar at the top (SCR3) to indicate that the slot is enabled. While the slot is enabled, all the setting changes of the meter, will be applied to the currently slot (SCR3).

7.4.6.2.- Options context menu



- Grid: ON/OFF. Shows/hide the grid.
- Carrier (only DVB-T/T2): All, TPS+continual (only DVB-T), Other. Allows you to select the constellation of the selected carrier(s).
- Layer (only ISDB-T/Tb): Allows to select the layer

7.4.7.- Echoes (RF Input)

This feature you allows to visualize the echoes of the received signal, helping the installer to minimize them as much as possible for optimal signal reception.

7.4.7.1.- Main window

The blue mark indicates the delay and the level of the signal
Drag to move

Orange mark indicates the minimum level of the echoes
Drag to move

List of measurements of the channel
Tap on i to see the parameters of the signal

List of echoes with the delay and level of each one

Num echoes: 1		
#	Delay(μs)	Level(dB)
0	5	-31.7

7.4.7.2.- Options context menu:

OPTIONS

- Min Level -36.9 dB
- Quality Profile >
- Powering >

Num echoes: 1		
#	Delay(μs)	Level(dB)
0	6	-31.3

•Min. Level: allows to indicate the level from which the meter must take account of the echoes. You

can also change this level by dragging the horizontal orange level.

- Zoom: OFF, 2x, 4x, 8x, 16x. You can also Spread/pinch on the screen.
- Units: us, Km.
- Quality profile: allows to select the quality profile
- Powering:

- VDC: Selects the preamplifier powering.
- DiSEqC (only satellite band): selects the DiSEqC parameter (Sat A, Sat B, Sat C, Sat D).
- Positioner (only satellite band): makes it possible to control the DiSEqC motors used to move mobile parabolic antennas. This function is available in satellite mode and when the equipment is powering the LNB.

Halt: This command stops the motor movement.

East: Allows to move the motor in the EAST direction. Each click corresponds to one step in the movement of the motor (pitch motors). By holding the key down, successive movement sequences will be executed until the key is released.

West: Motor movement in the WEST direction. Each click corresponds to one step in the movement of the motor (pitch motors). By holding the key down, successive movement sequences will be executed until the key is released.

Store: 8 storage positions are available to store at up to 8 antenna positions . This command allows one of 8 positions to be chosen where the current position of the antenna will be stored.

Goto: recovers one of the 8 positions for the antenna that has been previously stored

- SCR (only satellite band): Selects the SCR parameters (multiswitch, standard and slots) When a slot is enabled (for example slot 3, freq. 1210MHz), the meter will tune into the slot frequency (1210MHz) and will set the slot with the meter parameters: frequency, band (powering), and DiSEqC. In addition, a SCR icon will be shown in the bar at the top (SCR3) to indicate that the slot is enabled. While the slot is enabled, all the setting changes of the meter, will be applied to the currently slot (SCR3).

7.4.8.- MER/carrier (RF Input)

This feature represents MER value for each carrier of the DVB-T signal. This is pretty useful to detect if there is any interference inside the channel that makes the quality signal to get worse and that is invisible for a traditional spectral analysis.

7.4.8.1.- Main window

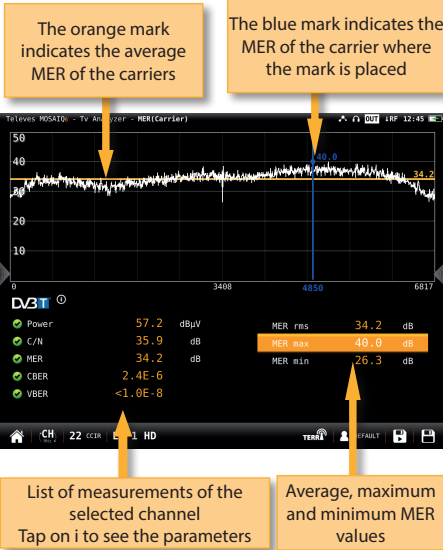

- MER RMS: Average MER of the DVB-T signal.
- MER max: Maximum MER value of the DVB-T signal. In parentheses the number of carrier with this maximum valuer of MER. If you tap on this measurement, the blue mark will move to the carrier with the maximum MER, and will be moving searching the carrier with maximum MER each time.
- MER min: Minimum MER value of the DVB-T signal. In parentheses the number of carrier with this minimum valuer of MER. If you tap on this measurement, the blue mark will move to the carrier with the minimum MER, and will be moving searching the carrier with minimum MER each time.

7.4.8.2.- Options context menu

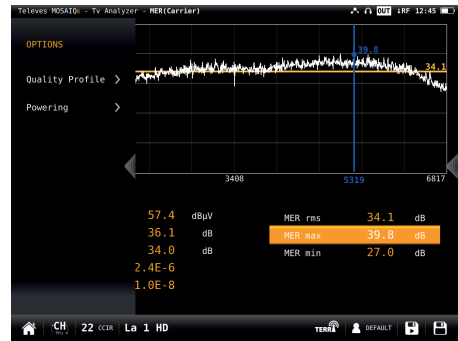

- Carrier: Allows to select the carrier where the user wants to measure the MER.
- Quality profile: allows to select the quality profile
- Powering: Selects the preamplifier powering.
- Min. Carrier: Allows you to select the minimum carrier to be shown in the graph.
- Max. Carrier: Allows you to select the maximum carrier to be shown in the graph.
- Reset Positions: Sets the minimum and maximum carriers shown in the graph to the maximum and minimum carriers of the channel.

7.4.9.- Uncorrected packets (RF Input)

This feature makes an uncorrected packet analysis during a timer interval selected by the user.

EN

7.4.9.1.- Main window



Total analysis: Start and end time of the analysis, and number of uncorrected packets in all the intervals analysed.

Current interval: Start and end time of the current interval, and number of uncorrected packets.

Previous interval: Start and end time of the previous interval and number of uncorrected packets.

Worst interval: Start and end time of the interval with more uncorrected packets, and number of uncorrected packets in the worst interval of analysis since it was started.

Locked: Time gone by since the demodulator locked to the digital signal the last time, longest time the digital signal was locked, and number of locking.

Unlocked: Time gone by since the demodulator unlocked to the digital signal the last time, longest time the digital signal was unlocked, and number of unlocking.

Error-free: Time gone by since last uncorrected packet, and longest time gone by since last uncorrected packet.

7.4.9.2.- Options context menu:



- Restart: restart the uncorrected packets analysis
- Interval: Change the analysis interval time. The interval is configurable between 1 minute and 1 hour.
- Powering:

- VDC: Selects the preamplifier powering.
- DiSEqC (only satellite band): selects the DiSEqC parameter (Sat A, Sat B, Sat C, Sat D).
- Positioner (only satellite band): makes it possible to control the DiSEqC motors used to move mobile parabolic antennas. This function is available in satellite mode and when the equipment is powering the LNB.
 - Halt: This command stops the motor movement.

East: Allows to move the motor in the EAST direction. Each click corresponds to one step in the movement of the motor (pitch motors). By holding the key down, successive movement sequences will be executed until the key is released.

West: Motor movement in the WEST direction. Each click corresponds to one step in the movement of the motor (pitch motors). By holding the key down, successive movement sequences will be executed until the key is released.

Store: 8 storage positions are available to store at up to 8 antenna positions. This command allows one of 8 positions to be chosen where the current position of the antenna will be stored.

Goto: recovers one of the 8 positions for the antenna that has been previously stored

- SCR (only satellite band): Selects the SCR

parameters (multiswitch, standard and slots) When a slot is enabled (for example slot 3, freq. 1210MHz), the meter will tune into the slot frequency (1210MHz) and will set the slot with the meter parameters: frequency, band (powering), and DiSEqC. In addition, a SCR icon will be shown in the bar at the top (SCR3) to indicate that the slot is enabled. While the slot is enabled, all the setting changes of the meter, will be applied to the currently slot (SCR3).

7.4.10.-IP Analysis (Ethernet Input)

This function makes a deep analysis of the IP signal, and shows the parameters of the signal and all the corresponding measures, as well as a chart that represents a history of the measurements in a period of time selected by the user.

7.4.10.1.- Main window

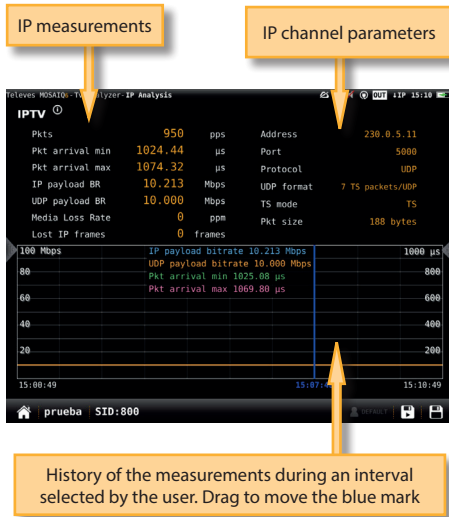

7.4.10.2.- Options context menu

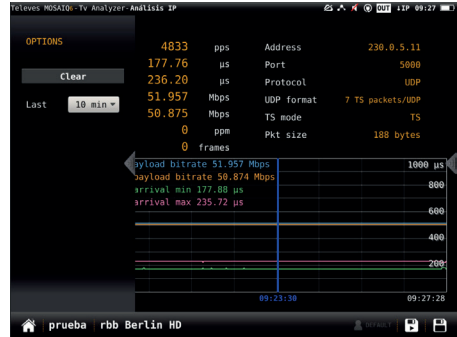

- Clear: clears the graph.
- Last: 10 min, ½ hour, 1hour, ½ day, 1 day, 1 week. Allows select the time interval shown in the graph.



8. Spectrum analyser

These feature has two screens: spectrum analyser and waterfall. Long swipe to switch between them.

8.1.- Spectrum analyser

This feature shows the spectrum of the input signal.

8.1.1.- Main window

Swipe to tune next/previous channel
Drag to tune any channel
Spread/Pinch to change span

Spectrum parameters

Power or C/N measurement.
Tap to change

Tap to enable/disable the marks

If you tap to enable the marks:

Drag to move the active mark

Tap to activate a mark
+ adds a new mark (max. 6).
- removes the active mark
Delta: measures the level difference between two marks

8.1.2.- Options context menu

The options menu includes: Span, Ref Level, dB/div, RBW, VBW, Advanced, Quality Profile, Powering, and Air antenna (OFF).

- Span: 100KHz, 1MHz, 5MHz, 10 MHz, 20 MHz, 50 MHz, 100 MHz, 200 MHz, 500 MHz, 1.0GHz, 2.0GHz, 3.3GHz, Other.
- Start Frequency: Allows the user to set the initial frequency of the spectrum graph.
- Stop Frequency: Allows the user to set the final frequency of the spectrum graph.

- Reference level: Auto, 50dBμV – 130dBμV
- RBW: 500 HzW – 5MHzW
- VBW: 100Hz – 1MHz
- Advanced: Access to spectrum advanced features:
 - Hold: enables/disables max. hold & min. hold features. Tapping on Clear button to restart hold trace.
 - Trigger: enables/disables the trigger by level feature. To select the level, tap on the label and a popup keyboard appears.
 - Fill: enables/disables the spectrum graph filled.
- Quality profile: allows to select the quality profile
- Powering:
 - VDC: Selects the preamplifier powering.
 - DiSEqC (only satellite band): selects the DiSEqC parameter (Sat A, Sat B, Sat C, Sat D).
 - Positioner (only satellite band): makes it possible to control the DiSEqC motors used to move mobile parabolic antennas. This function is available in satellite mode and when the equipment is powering the LNB.
 - Halt: This command stops the motor movement.
 - East: Allows to move the motor in the EAST direction. Each click corresponds to one step in the movement of the motor (pitch motors). By holding the key down, successive movement sequences will be executed until the key is released.
 - West: Motor movement in the WEST direction. Each click corresponds to one step in the movement of the motor (pitch motors). By holding the key down, successive movement sequences will be executed until the key is released.
 - Store: 8 storage positions are available to store at up to 8 antenna positions . This command allows one of 8 positions to be chosen where the current position of the antenna will be stored.
 - Goto: recovers one of the 8 positions for the antenna that has been previously stored
 - SCR (only satellite band): Selects the SCR parameters (multiswitch, standard and slots) When a slot is enabled (for example

slot 3, freq. 1210MHz), the meter will tune into the slot frequency (1210MHz) and will set the slot with the meter parameters: frequency, band (powering), and DiSEqC. In addition, a SCR icon will be shown in the bar at the top (SCR3) to indicate that the slot is enabled. While the slot is enabled, all the setting changes of the meter, will be applied to the currently slot (SCR3).

- Aim antenna:
 - Emits a modular audible signal. This is a useful feature to point antennas without having to look at the display
- Relative Marks: ON/OFF
 - If ON is selected, the marks will be relative to their position in the grid, not to their frequency.

8.2.- Waterfall

The waterfall diagram is a three-dimensional representation of the signal spectrum. Signal levels are converted to colours and displayed along a time axis.

8.2.1.- Main window

Swipe to tune next/previous channel
Drag to tune any channel
Spread/Pinch to change span

Spectrum parameters

Waterfall time axis is the vertical one and frequency axis is the horizontal one, while level is converted to colour through the colour scale in the top right side

Every spectrum trace in the top half generates a new waterfall line in the bottom half.

8.2.2.- Options context menu:

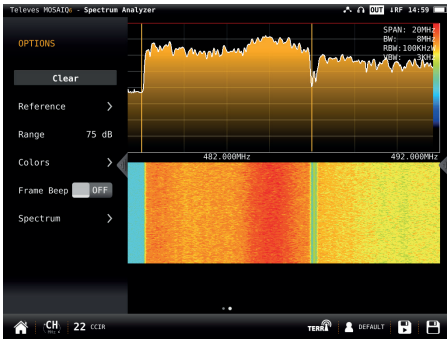

- Clear: It clears the waterfall display.
- Reference: it changes the level of the highest colour in the colour scale. Signal levels above this reference will be displayed in this colour.
- Range: it changes difference in dB between the highest and the lowest colour of the colour scale on the waterfall display.
- Colours: it changes the colour palette. Different colour combinations can be selected for the waterfall representation (Jet, Hot and BlueHot).
- Frame beep: when this option is ON, a beep sounds each time the waterfall screen fully refreshes, so there is no need to look at the screen continuously. Looking at the screen just when the beep sounds guarantees not missing any waterfall information.
- Spectrum: accesses to the spectrum options context menu (see section 7.1.- *Spectrum analyser*).



9. Radio Analyser

This feature is similar to TV Analysis in the radio band. So it has two screens: scan and mosaiq 3+1. Long swipe to switch between them.

9.1.- Scan Radio

This features scans the FM and DAB band.

The scan measurement leverages the location based thresholds to clearly show whether or not signal levels comply with the cable system's specifications with their green, yellow and red bar.

9.3.1.- Main window

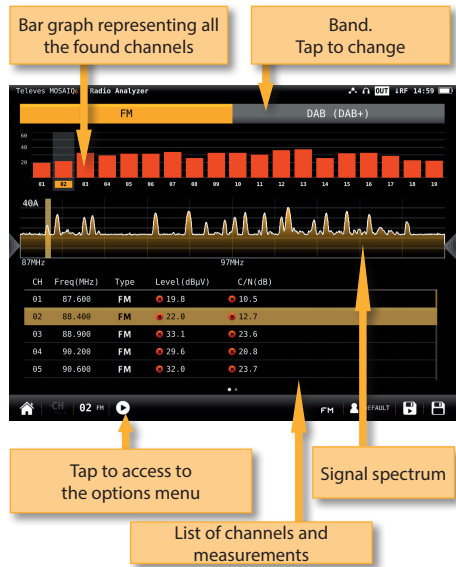

Tapping on icon  a popup window will appear:

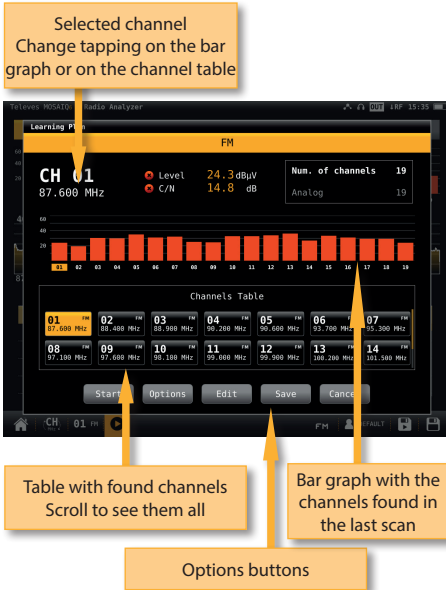

- Start: Starts a new system scan
- Options:
 - Fast: ON/OFF. When the fast scan is enabled (ON), the meter will not make CBER and MER measurements for DAB channels. So, only power and C/N measurements will be shown.
 - Wide outlet: ON/OFF. Enable this option when the outlet in your installation has both terrestrial and satellite bands. So, both bands will be scanned consecutively. If this options is disabled, only the selected band will be scanned.
Note: Note that if the selected user profile does not allow to make measurements in some bands, the scan will not be done in that band.
- Edit: Allows to add/delete channels from the plan. If the channel is selected (orange coloured), when you tap on it, it will be deselected. Otherwise, if the channel is unselected (grey coloured), when you tap on it, it will be selected.
- Save: Saves a new plan with the found channels.

•Cancel: Closes the options window

9.3.2.- Options context menu



- Fast: ON/OFF. When the fast scan is enabled (ON), the meter will not make CBER and MER measurements for DAB channels. So, only power and C/N measurements will be shown.
 - Show all: ON/OFF. When show all is ON, all the measurements of all the channels are shown. When it is OFF, you can only see the measurements of the channel that is being measured in that moment.
 - Span full: ON/OFF. When Span full ins ON you can see all the bars corresponding to all the found channels. When this option is OFF, only 24 bars are shown, so it is necessary to scroll to see them all.
 - Tilt: ON/OFF. When the tilt option is ON, this function measures the tilt between the channels indicated in the labels CH A and CH B. Then you can see a white line between these two channels and the tilt measurement on it.
 - Attenuation: ON/OFF. When the attenuation option is ON, the MOSAIQ6 measures the attenuation of the installation relative to a reference point, usually the head-end output. So, the first thing you must do is connect the meter to the reference point and tap on the Calibrate button. In this way, the equipment will measure and save the level of all the channels.
- Then you must go to all the pints of the installation where we want to measure and connect the meter, taking care to have this function ON. The MOSAIQ6 will measure the levels of all the channels comparing them with the reference ones.

EN

When this option is ON, the bars of the graphic don't represent the level or the power of the channels, but the attenuation of each one of them. The list shows power (or level) and C/N. In addition, a green trace is shown in the spectrum. This trace indicates the levels in the reference point.

- Quality profile: allows to select the quality profile .
- Powering: Selects the preamplifier powering.

9.2.- Mosaiq 3+1

This screen has 4 widgets, 3 in the top of the screen and one in the lower part of the screen. These widgets are user-configurable, that is, the user can select the function he or she wants to visualize in each widget.

9.2.1.- Main Window

Tap on the title bar of the widget to change the function

Double tap to see the feature in full screen

Short swap on the spectrum to change to previous/next channel

The available features are explained in section 9.3.- Radio features.

9.2.2.- Options context menu

- Quality profile: allows to select the quality profile .
- Powering: Selects the preamplifier powering.
- Filter (only for FM): Allows to select the filter to demodulate the FM signal

9.3.- Radio features

This section explains all the features available to visualize in the widgets of the Mosaiq 3+1 mode.

9.3.1.- Info radio

This feature shows the information of the tuned channel.

If it is a FM channel, the information shown is: RDS, PS name, PTY, PI, TP & radio text.

If it is a DAB channel, the information shown is: Ensemble, PTY, Service, Mode, Audio.

9.3.1.1.- Main Window

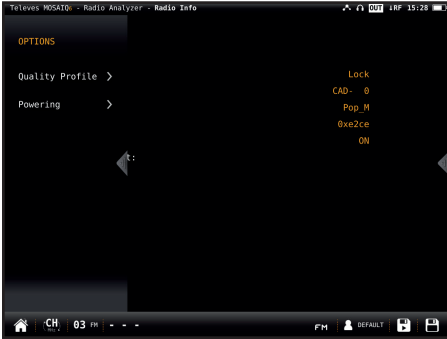

- Quality profile: allows to select the quality profile .
- Powering: Selects the preamplifier powering.

9.3.2.- Services (only for DAB channels)

This feature shows a graph representing the services distribution. Tapping on a section, you can see the name of the corresponding service.

9.3.2.1.- Main Window

Graph with the distribution of the channel services

List of services with IDs and bitrates. The colour of each square corresponds to the colour of the graph section

Distribution of the service's PIDs and bitrates

Service's PIDs. The colors indicate the type of PID

9.3.2.2.- Options context menu



- Quality profile: allows to select the quality profile .
- Powering: Selects the preamplifier powering.

9.3.3.- Measurements

This feature shows the measurements of the selected channel. The measurements depends on the type of channel:

FM: Level, C/N

DAB: Power, C/N, BER and MER

9.3.3.1.- Main window

List of measurements of the channel

List of signal parameters

History of the measurements during an interval selected by the user. Drag to move the blue mark

9.3.3.2.- Options context menu



- Clear: restarts the graph.
- Last: 5 min, ½ hour, ½ day, 1 day, 1 week. Allows select the time interval shown in the graph
- Quality profile: allows to select the quality profile
- Powering: Selects the preamplifier powering.



109. Wi-Fi Analyser

The **MOSAIQ6** is able to perform a full analysis of the Wi-Fi band in both 2,4GHZ, and 5GHZ bands. To change the band selection, tap on the corresponding icon placed in the bottom bar.

When you access to this feature, the **MOSAIQ6** activates the Wi-Fi automatically and, if it has been connected to an available Wi-Fi network before, the **MOSAIQ6** has saved the password, so it will connect to the same network again automatically.

The default selected Wi-Fi network is the first in the Wi-Fi list, in addition, this Wi-Fi is highlighted in the channel map of the widget in the bottom of the screen. The selected Wi-Fi does not have to match the Wi-Fi the MOSAIQ6 is connected to.

The screen corresponding to this feature is Mosaiq3+1 type. This configuration has 4 widgets, 3 square ones in the top and a rectangular in the bottom. The top widgets are user-configurable.

10.1.- Main window

Tap on the top bar to select the widget feature

Double-tap to see the feature screen in full screen

The rectangular widget shows the channel map feature

WiFi List

WiFi Measures

Channel Map

10.2.- Features

This section explains all the features available to visualize in Wi-Fi analyser function.

10.2.1- Wi-Fi List

This feature shows a list with all the Wi-Fi networks detected by the **MOSAIQ6**.

In this list, the user can select the Wi-Fi network whose measurements he wants to view by tapping on it.

Note: to minimize this widget, the user must tap twice on the line corresponding to the selected Wi-Fi, otherwise another Wi-Fi will be selected.

The list can be ordered by SSID, BSSID, channel name, frequency, encryption type or signal level, the user just has to tap on the header of the corresponding column.

10.2.2.1.- Main window

Tap on the column header to order the list according to that parameter

Tap on the Wi-Fi to select it

SSID	BSSID	CH	Freq	Encryption	Level (dBm)
Gsertel-Guest	12:da:43:c3:4a:d8	6	2437	WPA2	-51
triton-mesh-1	e2:a8:76:8a:bd:0d	6	2437	WPA2	-51
gsertel-radius	10:da:43:c3:4a:d8	6	2437	WPA2	-59
GL-AR150-17a	e6:95:6e:4f:01:7a	6	2437	WPA2	-60
Ladatel_2_4	ac:22:0b:d2:cd:a8	5	2432	WPA WPA2	-60
GL-AR150-5b8	e6:95:6e:41:e5:b8	6	2437	WPA WPA2	-61
Nighthawk	a0:63:91:30:de:a7	1	2412	WPA2	-62
HBBEVOLUTION_051917992	3c:a3:88:b9:4c:e7	5	2432	WPA2	-67
triton_2_4g	3c:37:06:71:49:6e	6	2437	WPA2	-67
RUT240-BB7C	02:1e:42:22:bb:7c	1	2412	WPA2	-71
RUT950-69AB	02:1e:42:22:69:ab	6	2437	WPA2	-72
V40_Thing-5B	3a:130:f9:eb:79:22	4	2427	WPA2	-58
dd-wrt	c0:56:27:1d:0d:00	6	2437		-69
Ladatel_Guest	c0:56:27:24:c2:3a	11	2462		-70
Trendnet-Guest	7a:0a:11:0a:01:06	11	2462	WPA2	-74

10.2.1.1.- Main window

Status and level measurement

Wi-Fi network parameters

Level measurement historical during a time interval selected by the user. Drag to move the blue marker

10.2.1.2.- Contextual options menu

- Clear: resets the chart.
- Last: 10 min, ½ hour, ½ day, 1 day, 1 week. Allows you to select the time interval shown in the chart.

10.2.1- Wi-Fi measurements

This feature shows all the measurements of the Wi-Fi network selected by the user.

The default selected Wi-Fi network is the first in the Wi-Fi list. To select another Wi-Fi, you must maximize the Wi-Fi List widget (see section 10.2.1.- Wi-Fi List), or the Channel Map widget (see section 10.2.4.- Channel Map)

10.2.3- Time graph

This feature shows a graph with the level measurement historical of all the Wi-Fi networks detected by the **MOSAIQ6**.

10.2.3.1.- Main window

You can select the Wi-Fi networks that you want to see in the graph

Select/unselect all the networks

History of the level measurement during an interval selected by the user

When this feature is maximized, the user can select a Wi-Fi using the “up” and “down” arrow buttons of the device. The selected Wi-Fi will be shown in the foreground.

10.2.4.1.- Main window

Graph with the distribution of all the Wi-Fi networks and the levels of the carriers

Parameters and level of the carrier of the selected Wi-Fi

10.2.3.2.- Contextual options menu

- Clear: resets the graph.
- Last: 10 min, ½ hour, ½ day, 1 day, 1 week. Allows select the time interval shown in the graph.

10.2.4- Channel map

This feature shows a graph with the distribution of all the Wi-Fi networks detected by the MOSAIQ6.



11. Network Tools

In this menu are grouped all the features that allow to check the network.

The screen corresponding to this feature is Mosaic4 type. This configuration has 4 widgets. All the widgets are user-configurable.

11.1.- Main window

Tap on the top bar to select the widget feature

Double-tap to see the feature screen in full screen

MOSAIQ6 network parameters

Orange icon if the ping is stopped
Green icon if the ping is running
Red icon if the connection to the server can not be established

IP address of the server.
Tap to change.
And packets loss measure

Televés MOSAIQ6 Net Tools - Ping

Connection Type	Ethernet	IP Destination	10.113.0.8
IP	10.113.0.179	Packets Loss/Send	3 / 11
Mask	255.255.0.0	Packets Loss	27 %
GW	10.113.0.1	Ping	18 ms
DNS	192.168.10.249		

ICMP SEQ TIME

3	18 ms
4	18 ms
5	18 ms
6	18 ms
7	-
8	-
9	-
10	19 ms
11	18 ms

Speed Test

384 Kbps

Start

11.2.1.1.- Main window

MOSAIQ6 network parameters

Orange icon if the ping is stopped
Green icon if the ping is running
Red icon if the connection to the server can not be established

IP address of the server.
Tap to change.
And packets loss measure

Televés MOSAIQ6 Net Tools - Ping

Connection Type	Ethernet	IP Destination	10.113.0.8
IP	10.113.0.179	Packets Loss/Send	3 / 11
Mask	255.255.0.0	Packets Loss	27 %
GW	10.113.0.1	Ping	18 ms
DNS	192.168.10.249		

ICMP SEQ TIME

3	18 ms
4	18 ms
5	18 ms
6	18 ms
7	-
8	-
9	-
10	19 ms
11	18 ms

List of the successive pings

Tap to Start/Stop the ping

11.2.- Features

This section explains all the features available to visualize in Network Tools function.

11.2.1- Ping

This function attempts to connect to the server selected by the user. If the connection is established, the **MOSAIQ6** makes successive pings to the server and shows the delay times.

11.2.2.- ARP Scan

The ARP (Address Resolution Protocol) Scan feature scans the devices in the network and returns the IP, the MAC and the manufacturer of each one.

11.2.2.1.- Main window

Number of devices founded

Tap to start the scan

List of devices with IP, MAC and manufacturer of each one

IP	MAC	MANUFACTURER
10.113.0.1	bc:16:15:ae:24:06	Cisco
10.113.0.2	cc:8e:71:5c:91:c5	(Unknown)
10.113.0.13	00:0f:1e:fd:94:2b	S-PRO
10.113.0.14	00:0e:7c:42:02:ad	Televex
10.113.0.15	7c:01:61:01:7f:01	(Unknown)
10.113.0.16	18:33:15:58:00:11	(Unknown)
10.113.0.17	0c:c4:7a:7b:15:1c	Super
10.113.0.19	00:0e:7c:43:00:1b	Televex
10.113.0.26	c4:34:6b:64:43:0e	Hewlett
10.113.0.28	00:e0:33:aa:00:76	E. E. P. D.
10.113.0.29	00:0e:7c:42:05:2e	Televex
10.113.0.30	20:10:ad:01:22	ASUSTek
10.113.0.32	00:0e:7c:43:00:1b	Televex

11.2.2.1.- Main window

Tap to edit the destination IP

Tap to start the scan

List of ports with the state and the service of each one

PORT	STATE	SERVICE
22 /TCP	Open	ssh
80 /TCP	Open	http
111 /TCP	Open	rpcbind
139 /TCP	Open	netbios-ssn
445 /TCP	Open	microsoft-ds
902 /TCP	Open	iss-realSecure
2049 /TCP	Open	nfs
111 /UDP	Open	rpcbind
123 /UDP	Open	ntp

11.2.3- NMAP Scan

The NMAP (Network Mapper) Scan feature and gets information of the enabled ports and services of the device with the IP selected by the user.

11.2.4- Speed Test

This function attempts to connect to the server, checks the DHCP protocol and the connection to the Internet. Then, the MOSAIQ6 makes a download and upload speed test.

11.2.3.1.- Main window

Orange icon while the test is running
Green icon if the speed is ok
Red icon if the speed is too low

Type of connection

117 Mbps

Download 443.39 Mbps
Upload 242.27 Mbps

Start

Measures of down and upstream speeds

Tap to start test



12. Drive Test

The Drive Test feature activates the GPS automatically. This is a suitable function to detect possible signal coverage problems in a specific area and find out what's causing it.

The screen corresponding to this feature is Mosaic3+1 type. This configuration has 4 widgets. All the widgets are user-configurable.

12.1.- Main window

Tap on the top bar to select the widget feature

Double-tap to see the feature screen in full screen

Status Running

GPS Status LOCKED

Last DVBT

#Channels 3

#Satellites 20

Power 78.6 dBmV

C/N 43.1 dB

MER 37.1 dB

CBER <1.0E-6

VBER <1.0E-8

Evolution

Sel. Channels

Stop the test

Pause/Run the test

Select channels to measure

When you tap on "Sel Channels", a pop-up window will show all the plans of the selected channel plan, so you can select those that you want to check in the drive test:

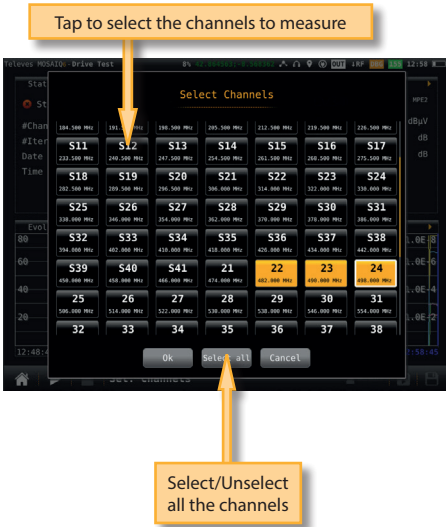

The channel analysis time is the time that each channel is analyzed before forward to the next channel, if AUTO is selected, Hexylon will forward to the next channel when it considers that the measurements will be stable. Note that, if the time necessary to perform the measurements on all the selected channels is greater than the time interval, the time between one iteration and the next one will be the minimum necessary to perform the measurements in all the selected channels.

12.2.- Features

This section explains all the features available to visualize in Network Tools function.

12.2.1- Status

This function shows the current status of the test.

12.2.1.1- Main window

Once you press the test start button, you must select the drive test file name, as well as the interval between measurements (you can choose between time interval or distance), the reference measurement (this is the one the map will use as a reference for the color of the icons), and the analysis time for each channel:

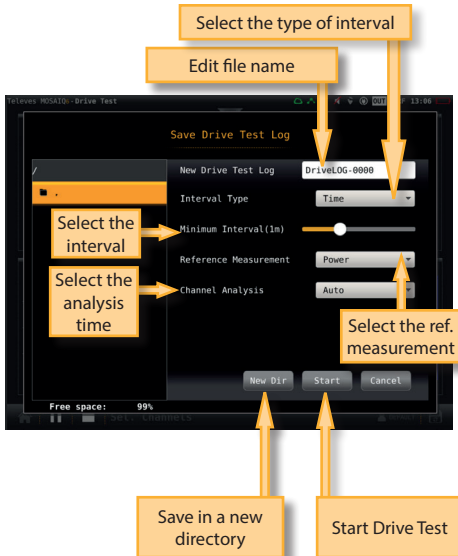

Orange icon if the test is paused
Green icon if the test is running
Red icon if the test is stopped

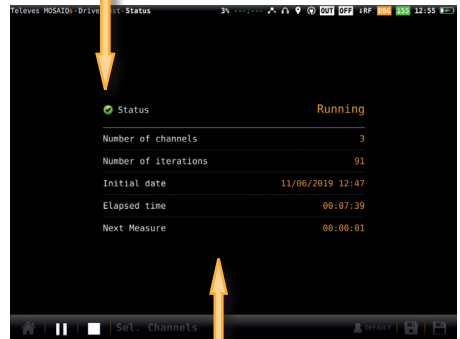

Number of channels: is the number of channels selected by the user to be measured in each iteration
Iterations: number of iterations of the test made from the start to now
Initial date: date when the test began
Elapsed time: time elapsed from the start date to now

12.2.2.- GPS

This function shows all the information of the GPS.

12.2.2.1.- Main window

Green icon if the GPS is locked
 Red icon if the GPS is unlocked



Number of satellites is the number of locked satellites
 Latitude, Longitude, Altitude: GPS measures
 Locked: is the time elapsed since the last time the GPS is locked

12.2.3.- Last

This function shows the current measurements obtained by the MOSAIQ6 during the drive test.

12.2.3.1.- Main window

List of measurements

List of signal parameters

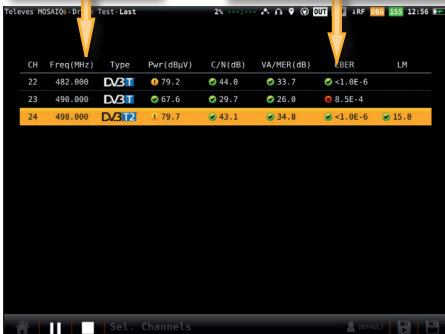

CH	Freq(MHz)	Type	Pwr(dBμV)	C/N((dB)	VA/MER((dB)	BER	LM
22	482.000	DVB-T	79.2	44.0	33.7	$3.1 \cdot 10^{-6}$	$1.0 \cdot 10^{-6}$
23	490.000	DVB-T	67.6	29.7	26.0	$8.5 \cdot 10^{-4}$	
24	490.000	DVB-T	79.7	43.1	34.8	$3.1 \cdot 10^{-6}$	$1.0 \cdot 10^{-2}$

12.2.4.- Evolution

This function shows the time evolution of the selected channel measurements obtained by the MOSAIQ6 during the drive test, as well as the current measurements in all the channels. The window is similar to the one of the section 7.4.3.- Measurements

12.2.4.1.- Main window

List of channels with the corresponding measurements

Tap to select the channel (in blue)

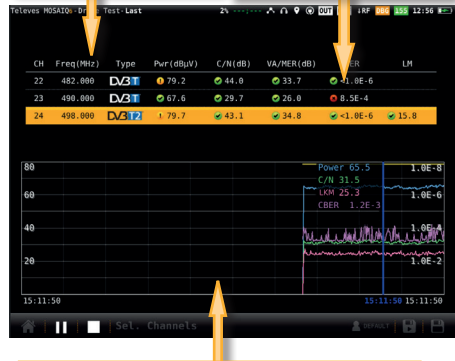

History of the measurements of the selected channel. Drag to move the blue mark



13. LOGS

The MOSAIQ6 saves two types of measurements files: LOGs and MacroLOGs.

A **LOG** saves all the measurements on the screen, as well as a screenshot. To save a LOG, tap on the icon  in the bottom bar.

A **MacroLOG** is a scheduled measurement that the meter repeats automatically in a time interval selected by the user.

To schedule a MacroLOG tap on icon  in the bottom bar.

Then a popup window will be open, where you can select the time interval. Then tap on the Start button:



The meter makes and saves the measurements in each specified time interval until the user taps on Stop button.

Tap on Stop to stop the MacroLOG



The LOGs feature allow us to see all the LOGs and MacroLOGs stored in the meter.

13.1- Main window

Stored LOGs Tap to select

Two views: Measurement and screenshot

Allows to select several logs in a directory

Saves LOG in USB memory

Creates a new directory

Deletes LOG

Renames LOG

For each LOG, there are two views:

- Measurement: shows a list with all the measurements

•Screenshot: shows a screenshot of the meter exactly as it is at the measurement time.

If you select a MacroLOG, you can also select the measurement iteration:

Drag to see the scheduled measurement iteration



Web application

To access your MOSAIQ6 web application, you must type the IP of your meter in the address bar of your web browser (Chrome recommended).

To know the IP of your meter, you must access to the top menu and select Network feature (see section *Settings in Top menu*).

The first time that you access to the web application you must use the following user and password:

User: admin

Password: admin

Then the web application will be open, showing the Resume window:

Tap to change password or logout



1.- Measurements

This feature shows all the LOGs and MacroLOGs stores in the meter.

There are two display modes:

•Calendar: the measurements are shown grouped by date in a calendar:

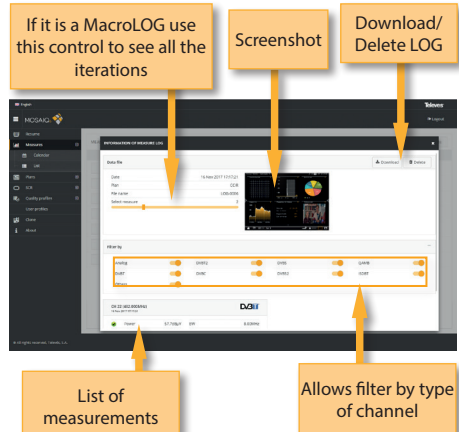
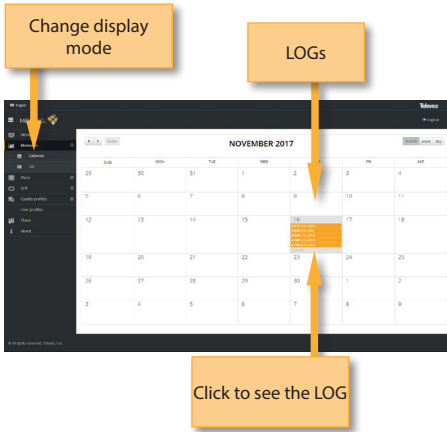

•List:



If the MacroLOG has, in addition, GPS information, you can see all the measurements iterations placed in a map in the position where they was made, so you have a detailed mapping and coverage analysis.

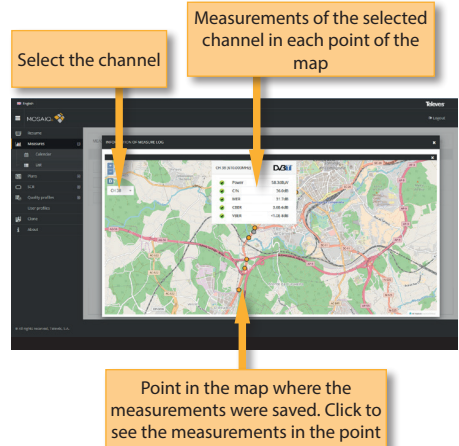

Once the LOG is selected, we see a window with all the information:

Using the buttons placed at the top right of the screen, you can remove the selected LOGs or download them to your computer in .xls format (it will be generated a .xls file for each LOG and they all will be downloaded together in a .zip file).

Note: please wait until the images or maps are displayed in your device screen before you download the file. This may take a few seconds.

2. Plans

In this window, you can see all the channel plans of your MOSAIQ6.

They are grouped in several categories: Terrestrial, Satellite, DAB, Customer, and IPTV.

The Terrestrial, Satellite and DAB channel plan are the standard channel plans of the corresponding band.

These plans can be removed from the meter, but they can not be edited. However, you can make a copy of one of them to build a new customer channel plan from it.

The duplicated plans will appear in the Customer list automatically..

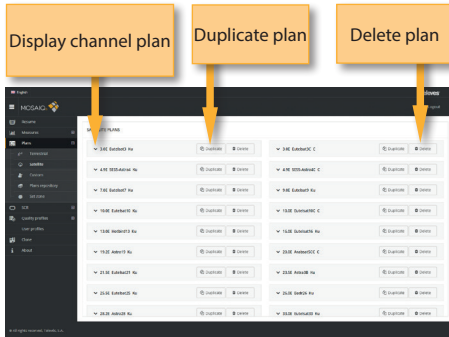

Mosaiq6 has no factory IPTV channel plan, neither FM plan. The user must create his own IPTV or FM channel plans.

To create a new channel plan, click on the Add button. As you can see in the image below, you must select the type of channel plan: terrestrial, satellite, FM, DAB or IPTV:

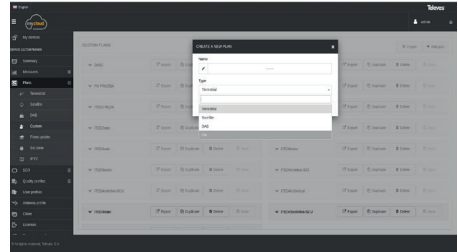

EN

You can add the IPTV channels one by one, or importing it from a .m3u file.

A .m3u file is a plain text file that specifies the locations of one or more media files. Each media file must have the following structure:

```
#EXTINF:-1, Das Erste HD
rtp://@239.228.245.1:10000
rtp://@239.228.245.58:10000
```

Each media file must begin with the "#EXTINF:" label.

"-1" indicates that it is a streaming file.

"," indicated that the next field is the channel name (in this case Das Erste HD) . If there is no name for a channel, a default name will be assigned.

At last it must appear the protocol and the address of the source. MOSAIQ6 only admits udp and rtp protocols.

If a channel does not meet some of these specifications, it will not be included in the plan.

Customer channel plans can be edited:

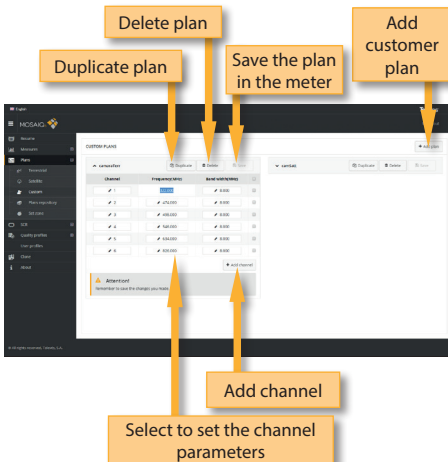

When the user select to import an IPTV channel plan from a .m3u file, the web app will ask you to select the file:

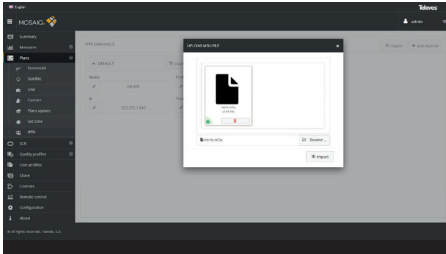

In this section, the user can also update the channel plans to the latest version saved in our server.

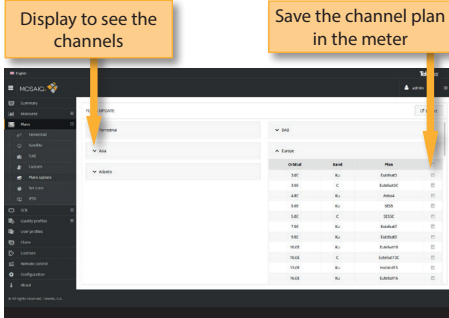

The application also allows to configure the channel plans according to the geographic area you will use the meter.

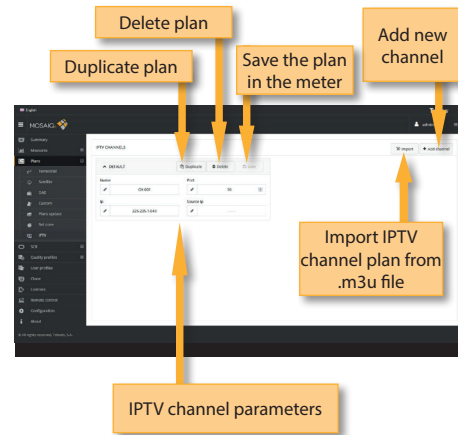

The user can select the channel plans using the feature Repository. In this window you can see all the channel plan grouped by zones.

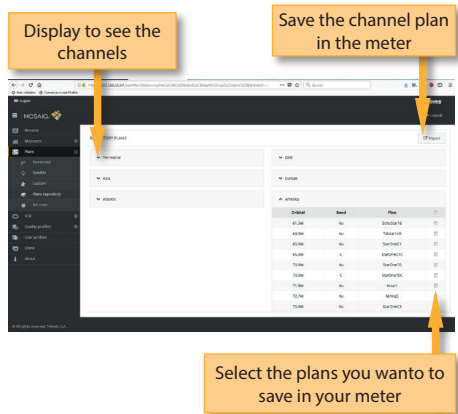

You can also upload to your meter the channel plans of a geographical zone automatically. To do that use the feature Set zone. In this window you can see a map of the world, and you can select the area where you will use the meter by clicking on it. With this and considering the language selected in your meter, the MOSAIQ6 will select automatically the channel plans both in terrestrial and satellite bands.

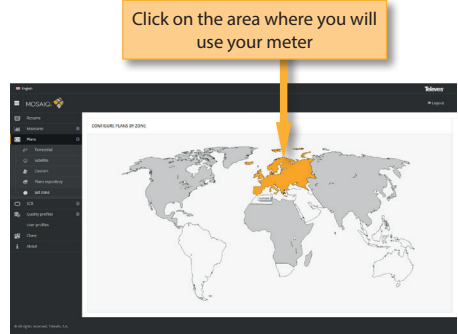

3. SCR

In this window, you can setup the multiswitches. The Mosaiq6 includes a list of multiswitches by default, but you can add more or edit any of the existing ones.

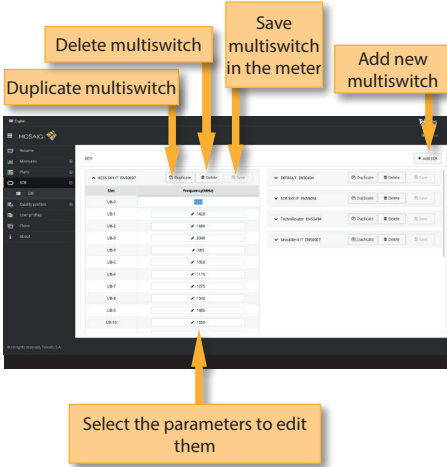

4. Quality profiles

Using the web application you can add new quality profiles. The MOSAIQ6 has two predefined quality profiles (head-end and outlet) that can not be edited, but they can be duplicated. The duplicated quality profiles are saved in the custom quality profiles, and the custom quality profiles can be edited.

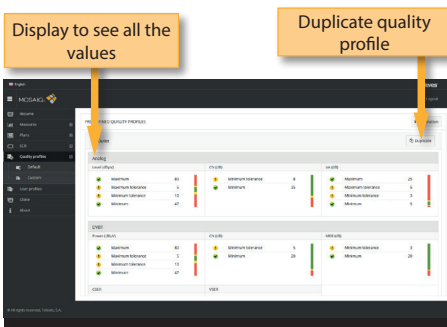

Custom quality profiles can be edited:

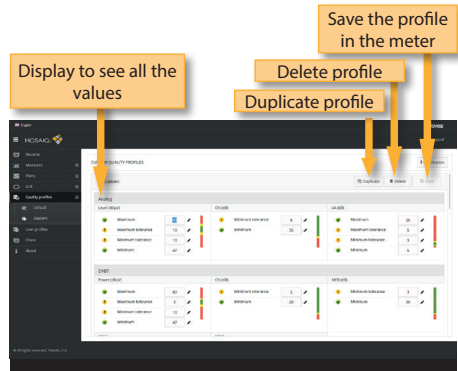

EN

5. User profiles

Using the web application you can add new user profiles. The MOSAIQ6 has one pre-defined user profile (named Default) that is configured automatically according to the geographical area selected by the user.

For each user profile, the user must select the band (or bands) that he or she wants to use in that profile, as well as the channel plan for each band other appropriate parameters, depending on the band.



6. Antenna profile

Using the web application you can add new antenna profile to your MOSAIQ6, to be used in in field strength measurement. See section *Inputs/Outputs* in *Top Menu* chapter.

The antenna profile will be load from a .csv file with three columns separated by comma (,): frequency (in MHz), K factor (in dB) when the antenna is being powered, K factor (in dB) when the antenna is not being powered.

Drag and drop or select .xlsx file

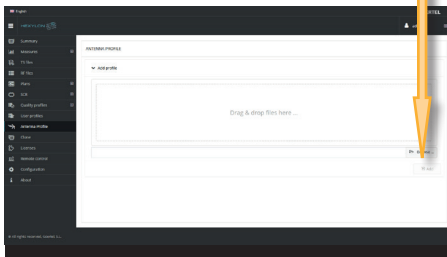

8. Licenses

Please contact the agents of our comercial network to purchase the license you wisht at any moment.

You will receive an e-mail with an attached file that you must save in yur computer.

Then select this feature to activate the license by dragging the file into the corresponding box that is shown on the screen, or find the file in your computer. Finally click on the Update button, the license will be activated in your **MOSAIQ6**.

9. Remote control

Using this feature you can control your MOSAIQ6 remotely. For this to work, it is necessary that the MOSAIQ6 and the computer are connected to the same LAN.

To access to this feature you must enter the password admin in the right top part of the window. Then you will see the screen of the MOSAIQ6 in your computer:



7. Clone

Using this feature it is very easy to have the same configuration in all your MOSAIQ6 meters.

You only have to export the configuration of the MOSAIQ6 that you want to copy, using the Export feature. So, the configuration will be saved in a file on you computer.

Then, connect other MOSAIQ6 where you want to copy the configuration to and select the Import feature.

Display to see Export feature

Click to export

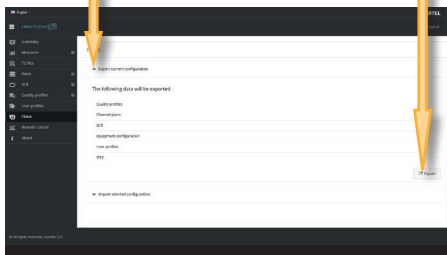

Using the mouse you can control the MOSAIQ6 with the hands, except the pinch/spread gestures.

10. Configuration

This feature allows you to restore the factory settings of your MOSAIQ6.

When you do that, all the measurements, channel plans, quality and user profiles stored in your meter will be deleted.

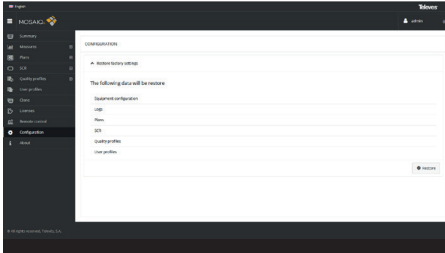

MOSAIQ6 Cloud

This functionality allows the user to have a replica of your meter in the cloud.

Each time the MOSAIQ6 is connected to the internet, the data in the cloud and the data in the MOSAIQ6 will be synchronized.

So, the user can add new channels plans, profiles, or change any other configuration while the MOSAIQ6 is being used to measure. Then, once the job is finished, you can connect your MOSAIQ6 to the internet, and automatically all the new settings will be applied to the meter, and the measurements saved during the workday will be saved in the cloud to be easily reviewed without having the MOSAIQ6 in the office.

To use this functionality, please follow these steps:

- Register yourself in our web (www.teledes.com). You only need an e-mail account.
- Then register your MOSAIQ6 in our web (See section *Before Starting*)
- Once both the user and the MOSAIQ6 are registered, you can access to the cloud of your MOSAIQ6

To access to the cloud, please type "https://mycloud.teledes.com" on your web browser address bar, and enter your user/password:

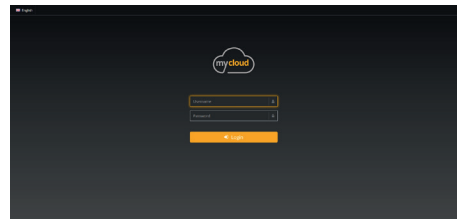

Then, a list with all the MOSAIQ6 meters registered by the user will be shown:

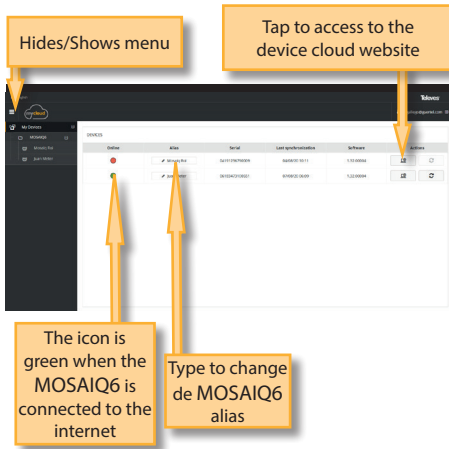

When the user access to the cloud website, a new page will be open:



The cloud website operates in the same way as the local website (see section *Web Application*).

Whenever the cloud synchronization is enabled (see section 1.4.- *Update in the Main Menu*), the MOSAIQ6 and the cloud synchronizes:

- Each time the MOSAIQ6 is connected to the internet
- Every 60 minutes (as long as the MOSAIQ6 is connected to the internet)
- Each time the user taps on the Synchronization button

All the data (measurements, profiles, channel plans, settings...), both on the MOSAIQ6 and on the cloud, will be synchronized attending to the most recent date.

Note: the changes will be applied to the meter when it is rebooted, or when the user taps on the button "Apply changes" in section 1.4.- *Update in the Main Menu*.

Error messages

LOW BATTERY

Indicates that the battery is about to finish. The battery icon is red now. It is recommended to connect the meter to the external power source.

LOW BATTERY

Shutting down Some time after the LOW BATTERY message appears (time varies depending on the functions used), it will appear this message. If the meter is not connected to the external power source, it will switch off.

BAD POWER

Unplug power source This message appears when the meter is connected to an external power source that does not supply it the right power. Please, use only the power source provided with the Mosaiq6.

SHORT-CIRCUIT

Check installation

This message appears when the meter detects a short-circuit at the RF input. It is recommended to check the installation to find out why the short circuit is produced.

DC OUTPUT LIMIT EXCEED

Switch DC OUTPUT off

This message appears when the meter detects an excessive consumption from the device that is being powered. It is recommended to turn off the powering feature of the MOSAIQ6.

DC AT RF INPUT

Check installation

This message appears when the meter detects DC at the RF input that is not generated by the MOSAIQ6. It is recommended to check the installation.

Maintenance

Always disconnect the unit before cleaning. Use only a mild solution of detergent and water applied with a soft damp cloth. Dry thoroughly before use.

Do not use aromatic hydrocarbons or chlorinated solvents. These products may damage the unit.

Do not use alcohol or alcohol based products on the front panel, especially the display.

These products may damage the unit.

Technical support

For any questions, contact Technical Support at www.televes.com

Before contacting Technical Support for repair, read the manual to ensure proper use and attempt to RESET the unit to clear any problems.

Repair service

Do not return the unit without first contacting Televes Technical Support.

If the unit needs to be returned, Televes will arrange for free shipping. The unit will need to be appropriately packed for shipping.

In compliance with IATA Regulations, when using our shipping service follow these instructions:

- Label the package.
- The equipment should fit as snugly as possible in the box. It is recommended to use the original packing materials.
- Attach the precaution label to the package.



Failure to comply with these shipping requirements may result in the shipping agent rejecting the package.

Warranty

Televes warrants, only to the original Purchaser, for a period of one (1) year from the date of original purchase, unless otherwise specified.

For the battery, due to the nature of the product, the warranty period is six (6) months.

Keep the purchase invoice to determine the warranty start date.

During the warranty period, Televes S.A. assumes any defect in materials or workmanship.

This warranty excludes any inoperability resulting from improper use, wear, service or repair performed by any third party not authorized, catastrophes or any cause unrelated to Televes S.A.



The terms HDMI, HDMI High-Definition Multimedia Interface, HDMI Trade dress and the HDMI Logos are trademarks or registered trademarks of HDMI Licensing Administrator, Inc.

 DECLARACIÓN DE CONFORMIDAD ■ DECLARATION OF CONFORMITY ■
 DECLARAÇÃO DE CONFORMIDADE ■ DECLARATION DE CONFORMITE
 ■ DICHIARAZIONE DI CONFORMITÀ ■ DEKLARACJA ZGODNOŚCI ■
 KONFORMITÄTSEKTLÄRUNG ■ ΠΙΣΤΟΠΟΙΗΤΙΚΟ ΣΥΜΜΟΡΦΩΣΗΣ ■
 FÖRSÄKRAN OM ÖVERENSSTÄMMELSE ■ ДЕКЛАРАЦИЯ СООТВЕТСТВИЯ ■

تقارب اطمعنا نايب ► www.doc.televes.com

European technology **Made in**  **EU**rope