

\*=Quota variabile per tipologia di cavo  
Variable dimension by type of cable

\*Dimensione max 57  
\*Max Dimension 57

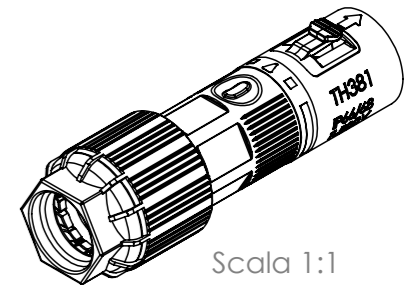
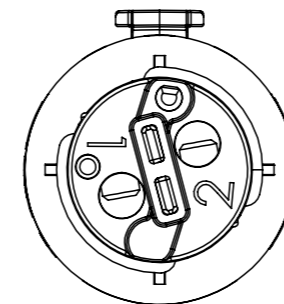
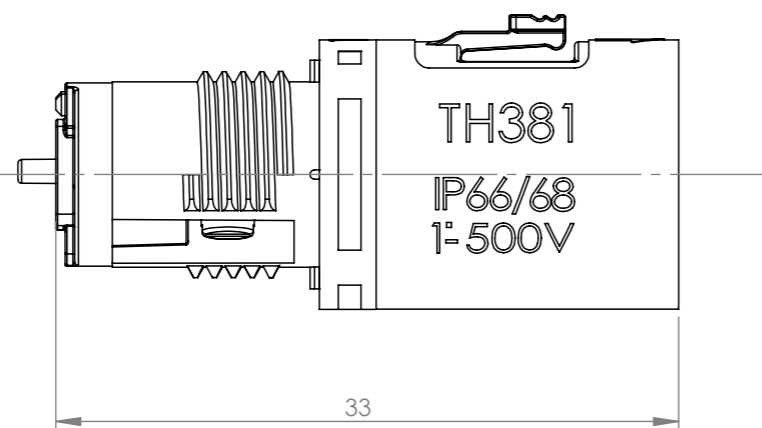
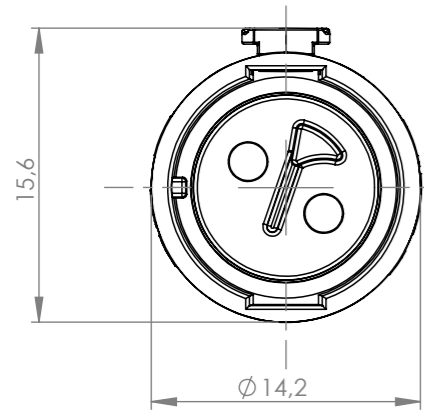
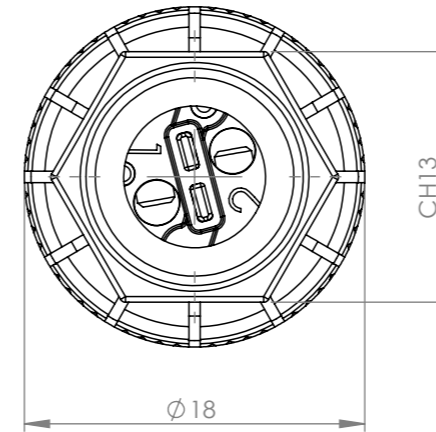
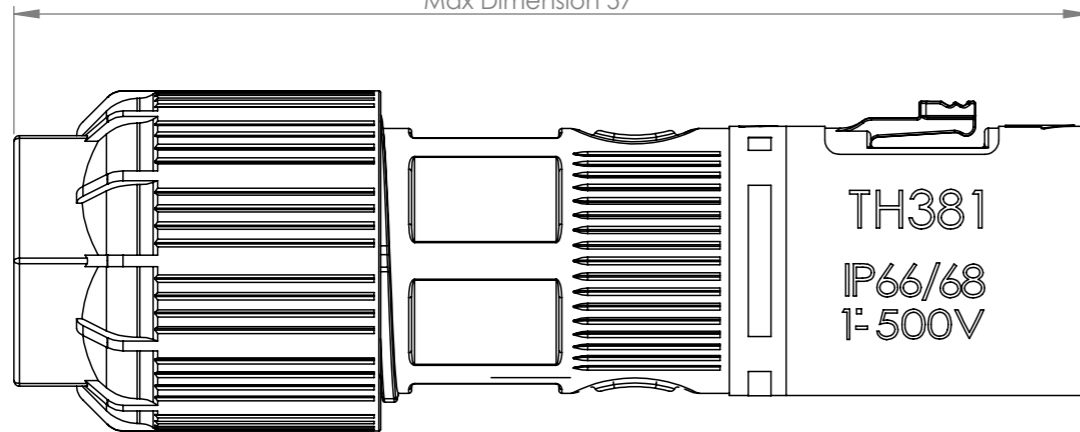

Tolleranze generali

Particolari stampati in materiale termoplastico: rif ISO 2768MK - Particolari lavorati alle macchine utensili: rif. UNI EN 22768  
Particolari tranciati in metallo: rif. UNI EN 22768 - grado IT10 per dim. lineari - grado IT11 quote di piega - angoli di piega ± 1

ACCESSORI / ACCESSORIES

COD. 6000462CC

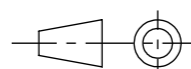

Questo disegno è proprietà esclusiva di Techno s.p.a. e non può essere copiato, ristampato, o comunque utilizzato senza permesso scritto dalla Techno s.p.a. in qualsiasi forma e per qualsiasi scopo. This drawing and all information contained here can not be used or reproduced, integrally or partially, without Techno s.p.a. written authorization.	Materiale-Material:		Titolo-Title:		
	Trattamento-Treatment:		Micro-Connector Plug 2P Screw IP68 Vers Up		
	N° documento cliente Customer ref		Peso [gr]: Weight [gr]:	9.54	
	Disegnato - Drawn by:	G.Flores	Data: Date:	2025-10-29	
Disegnato - Drawn by:	G.Flores	Data: Date:	2025-10-29	Scala-Scale:	2:1
Controllato-Checked by:	M.Strada	Data: Date:	2026-03-11	Formato - Format	A3
			N° Disegno - Drawing N°		
			THB.381.A2AU		
			Nome file - Filename		
			THB.381.A2AU		
Rev.	00	Foglio N° Sheet N°	1	N° Fogli N° of sheets	1