



Caratteristiche meccaniche

Peso prodotto

g 123

Dimensioni

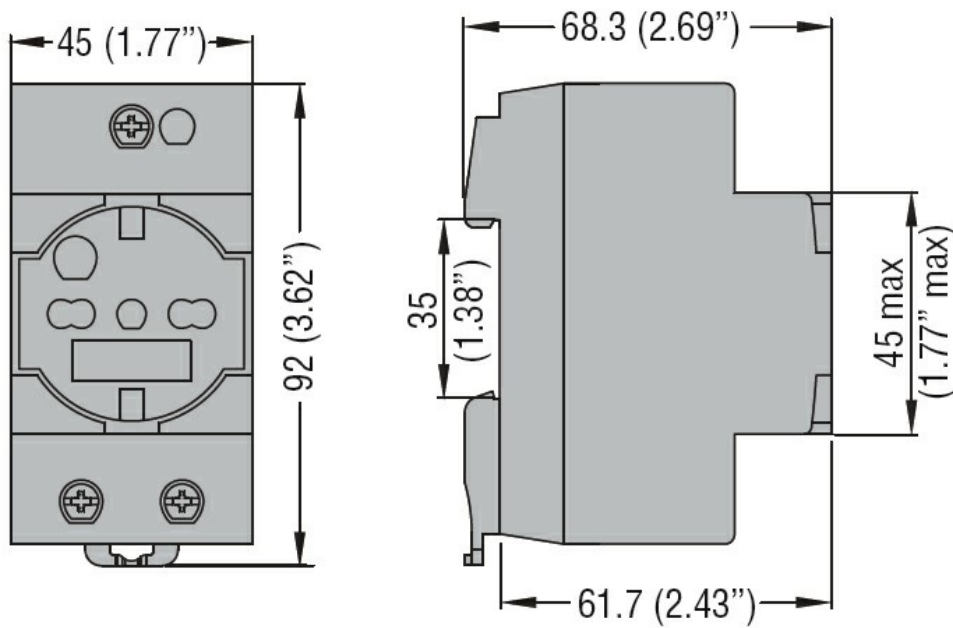

Omologazioni e conformità

Omologazioni

IEC/EN 60884-1

Certificazioni

EAC

Classificazione ETIM

ETIM 8.0

EC000330 -
Presca multipla