

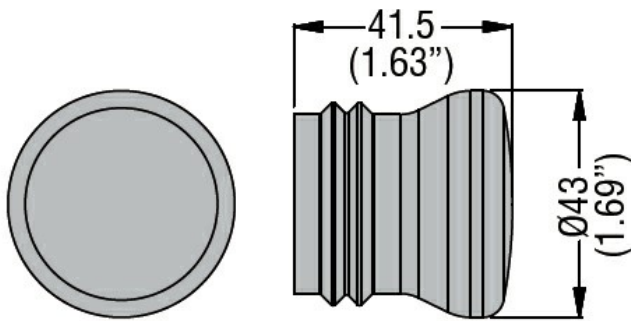

**Mechanical features**

Weight g 12

**Dimensions**



**Certifications and compliance**

Compliance /

Certificates /

**ETIM classification**

ETIM 8.0 EC002040 - Protective cap for command devices