



### General characteristics

#### Material

Housing	Aluminium-zinc alloy
Roller	Plastic

### Contact characteristics

Type of contact		1NO+1NC Snap action
Thermal current I <sub>th</sub>	A	10
IEC/EN 60947-5-1 designation		B300 R300
Rated insulation voltage U <sub>i</sub>	V	400
Rated impulse withstand voltage U <sub>imp</sub>	kV	4
Insulation class		I
IEC Conventional free air thermal current I <sub>th</sub> ≤ 40°C	A	10
Resistance per pole (average value)	mΩ	<25
Conductivity		10mA 5V

### Mechanical features

Operating head fixing		Fixed
Operating torque	N	10
	lb	2.2
Tightening torque (Max)		
Switch fixing	Nm	2.5
	lbin	22.1
Cable connection		2m / 5xAWG18-0.75mm <sup>2</sup> PVC Style 2517
Weight	g	290

### Operations

Mechanical life	cycles	>10000000
Mechanical operation	cycles/h	3600

### Ambient conditions

Temperature			
Operating temperature	min	°C	-25
	max	°C	+70
Storage temperature	min	°C	-40
	max	°C	+70

### Resistance & Protection

IP degree	Body housing	IP67
Pollution degree		3

### Dimensions

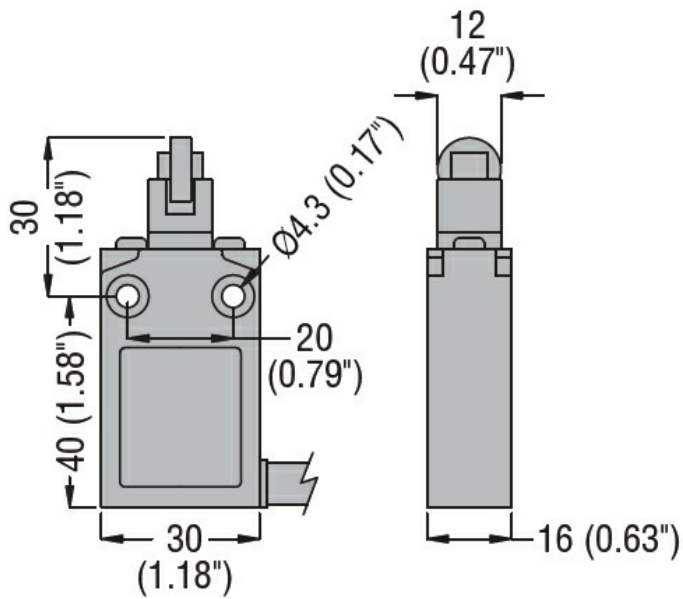

### Wiring diagrams

## Snap action

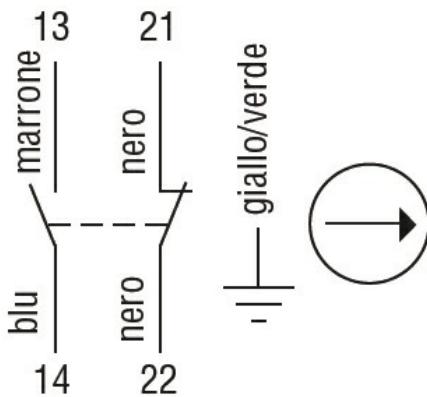

## 1NO + 1NC

### Certifications and compliance

#### Compliance

CSA C22.2 n° 14.

IEC/EN 60947-1

IEC/EN 60947-5-1

UL508

#### Certificates

cULus

EAC

### ETIM classification

ETIM 8.0

EC000030 - End  
switch