



Contact characteristics

Number of poles	Nr.	3
Rated insulation voltage U_i IEC/EN	V	1000
Rated impulse withstand voltage U_{imp}	kV	8
Operational frequency	min	Hz 25
	max	Hz 400
IEC Conventional free air thermal current $I_{th} \leq 40^\circ C$	A	140
Operational current I_e	AC-1 ($\leq 40^\circ C$)	A 140
	AC-1 ($\leq 55^\circ C$)	A 115
	AC-1 ($\leq 70^\circ C$)	A 100
	AC-3 ($\leq 440V \leq 55^\circ C$)	A 95
	AC-4 (400V)	A 45
Rated operational power AC-3 ($T \leq 55^\circ C$)	230V	kW 30
	400V	kW 55
	415V	kW 55
	440V	kW 55
	500V	kW 75
	690V	kW 90
	1000V	kW 45
Rated operational current AC-3 ($T \leq 55^\circ C$)	230V	A 95
	400V	A 95
	415V	A 95
	440V	A 95
	500V	A 95
	690V	A 93
	1000V	A 33
IEC max current I_e in DC1 with $L/R \leq 1ms$ with 1 poles in series	$\leq 24V$	A 140
	48V	A 140
	75V	A 100
	110V	A 10
	220V	A -
IEC max current I_e in DC1 with $L/R \leq 1ms$ with 2 poles in series	$\leq 24V$	A 140
	48V	A 140
	75V	A 140
	110V	A 110
	220V	A 12
IEC max current I_e in DC1 with $L/R \leq 1ms$ with 3 poles in series	$\leq 24V$	A 140
	48V	A 140

	75V	A	155
	110V	A	120
	220V	A	125
<hr/>			
IEC max current I _e in DC1 with L/R ≤ 1ms with 4 poles in series			
	≤24V	A	140
	48V	A	140
	75V	A	155
	110V	A	140
	220V	A	140
<hr/>			
IEC max current I _e in DC3-DC5 with L/R ≤ 15ms with 1 poles in series			
	≤24V	A	140
	48V	A	44
	75V	A	36
	110V	A	6
	220V	A	–
<hr/>			
IEC max current I _e in DC3-DC5 with L/R ≤ 15ms with 2 poles in series			
	≤24V	A	140
	48V	A	63
	75V	A	60
	110V	A	55
	220V	A	7
<hr/>			
IEC max current I _e in DC3-DC5 with L/R ≤ 15ms with 3 poles in series			
	≤24V	A	140
	48V	A	115
	75V	A	90
	110V	A	85
	220V	A	76
<hr/>			
IEC max current I _e in DC3-DC5 with L/R ≤ 15ms with 4 poles in series			
	≤24V	A	140
	48V	A	110
	75V	A	110
	110V	A	105
	220V	A	95
<hr/>			
Short-time allowable current for 10s (IEC/EN60947-1)		A	760
<hr/>			
Protection fuse			
	gG (IEC)	A	160
	aM (IEC)	A	100
<hr/>			
Making capacity (RMS value)		A	1200
<hr/>			
Breaking capacity at voltage			
	440V	A	1100
	500V	A	775
	690V	A	745
<hr/>			
Resistance per pole (average value)		mΩ	0.45
<hr/>			
Power dissipation per pole (average value)			
	I _{th}	W	8.8
	AC-3	W	4.1
<hr/>			
Tightening torque for terminals			
	min	Nm	6
	max	Nm	7
	min	I _{bin}	4.4
	max	I _{bin}	5.2
<hr/>			
Tightening torque for coil terminal			
	min	Nm	0.8

		max	Nm	1
		min	Ibin	0.59
		max	Ibin	0.74
Conductor section	AWG/Kcmil	max		2/0
	Flexible w/o lug conductor section	min	mm ²	1.5
		max	mm ²	70
	Flexible c/w lug conductor section	min	mm ²	1.5
		max	mm ²	70
Power terminal protection according to IEC/EN 60529				IP20 front
Mechanical features				
Operating position		normal allowable		Vertical plan ±30°
Fixing				Screw / DIN rail 35mm
Weight			g	2020
Auxiliary contact characteristics				
Thermal current I _{th}			A	140
Operations				
Mechanical life			cycles	15000000
Electrical life			cycles	1400000
Safety related data				
Performance level B10d according to EN/ISO 13489-1		rated load mechanical load	cycles	1400000
			cycles	15000000
AC coil operating				
Rated AC voltage at 60Hz			V	220
AC operating voltage	of 50/60Hz coil powered at 50Hz drop-out	max	%Us	55
	of 60Hz coil powered at 60Hz pick-up	min	%Us	80
		max	%Us	110
	drop-out	min	%Us	20
		max	%Us	55
AC average coil consumption at 20°C	of 60Hz coil powered at 60Hz	in-rush holding	VA	300
			VA	20
Dissipation at holding ≤20°C 50Hz			W	6.5
Max cycles frequency				
Mechanical operation			cycles/h	1500
Operating times				
Average time for U _s control in AC	Closing NO	min	ms	16

Opening NO	max	ms	32
	min	ms	9
	max	ms	24

UL technical data

Rated operational voltage AC (UL)	V	600
-----------------------------------	---	-----

Yielded mechanical performance

for three-phase AC motor

200/208V	HP	30
220/240V	HP	30
460/480V	HP	60
575/600V	HP	75

General USE

Contactor

AC current	A	150
------------	---	-----

Short-circuit protection fuse, 600V

High fault

Short circuit current	kA	100
Fuse rating	A	200
Fuse class		J

Standard fault

Short circuit current	kA	10
Fuse rating	A	250
Fuse class		RK5

Ambient conditions

Temperature

Operating temperature

min	°C	-50
max	°C	70

Storage temperature

min	°C	-60
max	°C	+80

Max altitude

m	3000
---	------

Dimensions

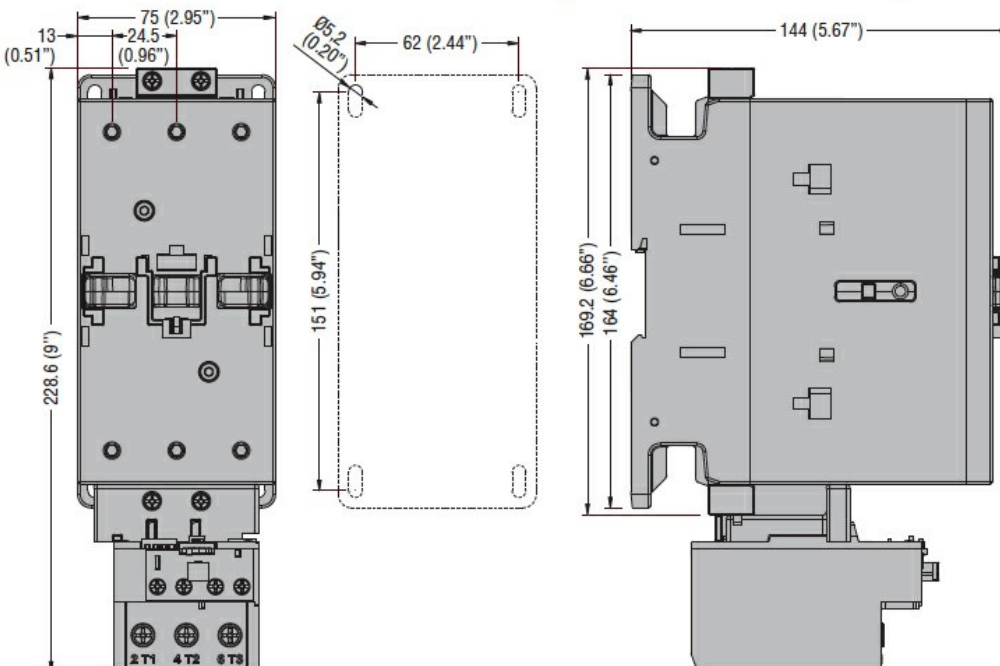

Wiring diagrams

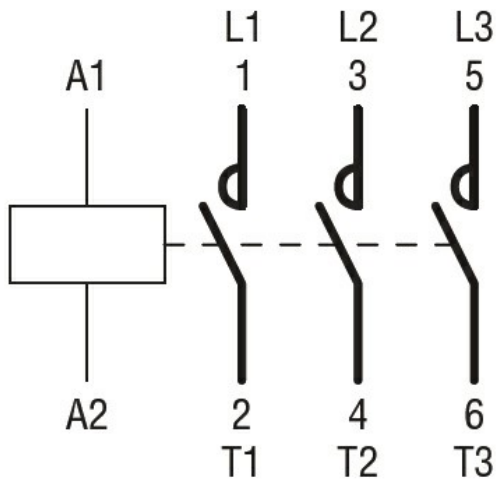

Certifications and compliance

Compliance

CSA C22.2 n° 60947-1

CSA C22.2 n° 60947-4-1

IEC/EN 60335-2-89

IEC/EN/BS 60947-1

IEC/EN/BS 60947-4-1

UL 60947-1

UL 60947-4-1

Certificates

CCC

CSA C22.2 n. 60335-2-40:22 LZGH A2L

CSA C22.2 No. 60335-2-89:21 LZGH A2L

cULus

UL 60335-2-40 LZGH A2L

UL 60335-2-89 LZGH A2L

ETIM classification

ETIM 8.0

EC000066 -
Power contactor,
AC switching