



### Contact characteristics

Number of poles	Nr.	4
Rated insulation voltage U <sub>i</sub> IEC/EN	V	1000
Rated impulse withstand voltage U <sub>imp</sub>	kV	8
Operational frequency	min	Hz 25
	max	Hz 400
IEC Conventional free air thermal current I <sub>th</sub> ≤ 40°C	A	115
Operational current I <sub>e</sub>	AC-1 (≤40°C)	A 115
	AC-1 (≤55°C)	A 95
	AC-1 (≤70°C)	A 80
	AC-3 (≤440V ≤55°C)	A 80
	AC-4 (400V)	A 38
Rated operational current AC-3 (T≤55°C)	230V	A 80
	400V	A 80
	415V	A 80
	440V	A 80
	500V	A 78
	690V	A 57
	1000V	A 28
Rated operational power AC-1 (T≤40°C)	230V	kW 43
	400V	kW 76
	500V	kW 95
	690V	kW 120
Short-time allowable current for 10s (IEC/EN60947-1)	A	640
Protection fuse	gG (IEC)	A 125
	aM (IEC)	A 80
Making capacity (RMS value)	A	800
Breaking capacity at voltage	440V	A 640
	500V	A 625
	690V	A 456
Resistance per pole (average value)	mΩ	0.6
Power dissipation per pole (average value)	I <sub>th</sub>	W 7.9
	AC-3	W 3.8
Tightening torque for terminals	min	Nm 4
	max	Nm 5
	min	lbin 2.95
	max	lbin 3.69

Tightening torque for coil terminal

min	Nm	0.8
max	Nm	1
min	I <sub>bin</sub>	0.8
max	I <sub>bin</sub>	0.74

Max number of wires simultaneously connectable

Nr.	2
-----	---

Conductor section

AWG/Kcmil

max	2
-----	---

Flexible w/o lug conductor section

min	mm <sup>2</sup>	1.5
max	mm <sup>2</sup>	35

Flexible c/w lug conductor section

min	mm <sup>2</sup>	1.5
max	mm <sup>2</sup>	35

Power terminal protection according to IEC/EN 60529

IP20 front

**Mechanical features**

Operating position

normal allowable	Vertical plan ±30°
------------------	--------------------

Fixing

Screw / DIN rail  
35mm

Weight

g 1360

**Operations**

Mechanical life

cycles 15000000

Electrical life

cycles 1300000

**Safety related data**

Performance level B10d according to EN/ISO 13489-1

rated load	cycles	1300000
mechanical load	cycles	15000000

EMC compatibility

yes

**AC coil operating**

Rated AC voltage at 50/60Hz, 60Hz

min	V	20
max	V	48

AC operating voltage

of 50/60Hz coil powered at 50Hz  
pick-up

min	%Us	85 Us min
max	%Us	110 Us max

drop-out

max	%Us	≤70 Us min
-----	-----	------------

of 50/60Hz coil powered at 60Hz  
pick-up

min	%Us	85 Us min
max	%Us	110 Us max

drop-out

max	%Us	≤70 Us min
-----	-----	------------

AC average coil consumption at 20°C

of 50/60Hz coil powered at 50Hz

in-rush	VA	90
holding	VA	2.7

of 50/60Hz coil powered at 60Hz

	in-rush	VA	90
	holding	VA	2.7
of 60Hz coil powered at 60Hz			
	in-rush	VA	90
	holding	VA	2.7
Dissipation at holding $\leq 20^{\circ}\text{C}$ 50Hz		W	1...2.5
<b>DC coil operating</b>			
DC rated control voltage			
	min	V	20
	max	V	48
max		V	48
DC operating voltage			
pick-up			
	min	%Us	80 Us min
	max	%Us	110 Us max
drop-out			
	max	%Us	$\leq 70$ Us min
Average coil consumption $\leq 20^{\circ}\text{C}$			
	in-rush	W	67
	holding	W	1.3
<b>Max cycles frequency</b>			
Mechanical operation		cycles/h	1500
<b>Operating times</b>			
Average time for Us control			
in AC			
Closing NO	min	ms	12
	max	ms	28
Opening NO	min	ms	8
	max	ms	22
in DC			
Closing NO	min	ms	40
	max	ms	85
Opening NO	min	ms	20
	max	ms	55
<b>UL technical data</b>			
Rated operational voltage AC (UL)		V	600
Full-load current (FLA) for three-phase AC motor			
	at 480V	A	77
	at 600V	A	77
Yielded mechanical performance			
for three-phase AC motor			
	200/208V	HP	25
	220/240V	HP	30
	460/480V	HP	60
	575/600V	HP	75
General USE			
Contactor			
	AC current	A	115
<b>Ambient conditions</b>			
Temperature			

Operating temperature

min	°C	-40
max	°C	70

Storage temperature

min	°C	-50
max	°C	80

Max altitude

m 3000

**Resistance & Protection**

Pollution degree

3

**Dimensions**

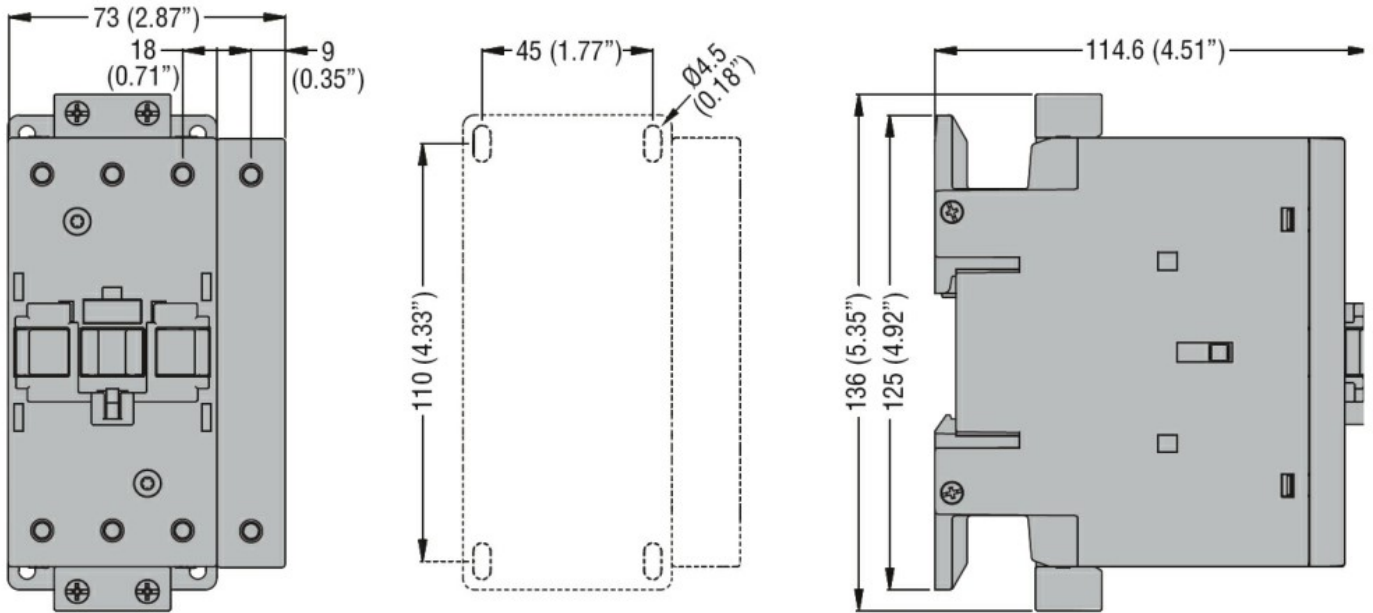

**Wiring diagrams**

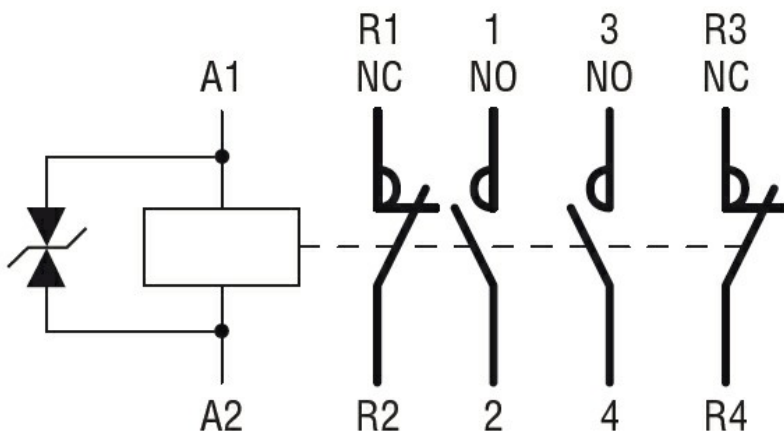

**Certifications and compliance**

Compliance

CSA C22.2 n° 60947-1

CSA C22.2 n° 60947-4-1

IEC/EN 60335-2-89

IEC/EN/BS 60947-1

IEC/EN/BS 60947-4-1

UL 60947-1

UL 60947-4-1

Certificates

CCC

CSA C22.2 n. 60335-2-40:22 LZGH A2L

CSA C22.2 No. 60335-2-89:21 LZGH A2L

cULus

UL 60335-2-40 LZGH A2L

UL 60335-2-89 LZGH A2L

**ETIM classification**

ETIM 8.0

EC000066 -  
Power contactor,  
AC switching