



Contact characteristics

Number of poles	Nr.	4
Rated insulation voltage U_i IEC/EN	V	690
Rated impulse withstand voltage U_{imp}	kV	6
Operational frequency	min	Hz 25
	max	Hz 400
IEC Conventional free air thermal current $I_{th} \leq 40^\circ\text{C}$	A	10
Protection fuse	gG (IEC)	A 25
Tightening torque for terminals	min	Nm 1.5
	max	Nm 1.8
	min	lbin 1.1
	max	lbin 1.5
Tightening torque for coil terminal	min	Nm 0.8
	max	Nm 1
	min	lbin 0.8
	max	lbin 0.74
Max number of wires simultaneously connectable	Nr.	2
Conductor section	AWG/Kcmil	
	max	10
Flexible w/o lug conductor section	min	mm ² 1
	max	mm ² 6
Flexible c/w lug conductor section	min	mm ² 1
	max	mm ² 4
Flexible with insulated spade lug conductor section	min	mm ² 1
	max	mm ² 4
Power terminal protection according to IEC/EN 60529		IP20 when properly wired

Mechanical features

Operating position	normal allowable	Vertical plan $\pm 30^\circ$
Fixing		Screw / DIN rail 35mm
Weight	g	496

Auxiliary contact characteristics

Thermal current I_{th}	A	10
IEC/EN 60947-5-1 designation		A600 - P600

Operating current AC15	230V	A	3
	400V	A	1.9
	500V	A	1.4
Operating current DC12	110V	A	5.7
Operating current DC13	24V	A	5.7
	48V	A	2.9
	60V	A	2.3
	110V	A	1.25
	125V	A	1.1
	220V	A	0.55
	600V	A	0.2

Operations

Mechanical life	cycles	20000000
-----------------	--------	----------

Safety related data

Performance level B10d according to EN/ISO 13489-1	mechanical load	cycles	20000000
--	-----------------	--------	----------

EMC compatibility	yes
-------------------	-----

DC coil operating

DC rated control voltage	V	110
--------------------------	---	-----

DC operating voltage	pick-up	min	%Us	70
		max	%Us	125
drop-out	min	%Us	10	
	max	%Us	40	

Average coil consumption $\leq 20^{\circ}\text{C}$	in-rush	W	5.4
	holding	W	5.4

Max cycles frequency

Mechanical operation	cycles/h	3600
----------------------	----------	------

Operating times

Average time for Us control in DC	Closing NO	min	ms	54
		max	ms	66
	Opening NO	min	ms	14
		max	ms	17
	Closing NC	min	ms	24
		max	ms	30
	Opening NC	min	ms	47
		max	ms	57

UL technical data

Rated operational voltage AC (UL)	V	600
-----------------------------------	---	-----

General USE	Auxiliary contacts	AC current	A	10
-------------	--------------------	------------	---	----

Contact rating of auxiliary contacts according to UL

A600 - P600

Ambient conditions

Temperature

Operating temperature

min	°C	-50
max	°C	70

Storage temperature

min	°C	-60
max	°C	80

Max altitude

m 3000

Resistance & Protection

Pollution degree

3

Dimensions

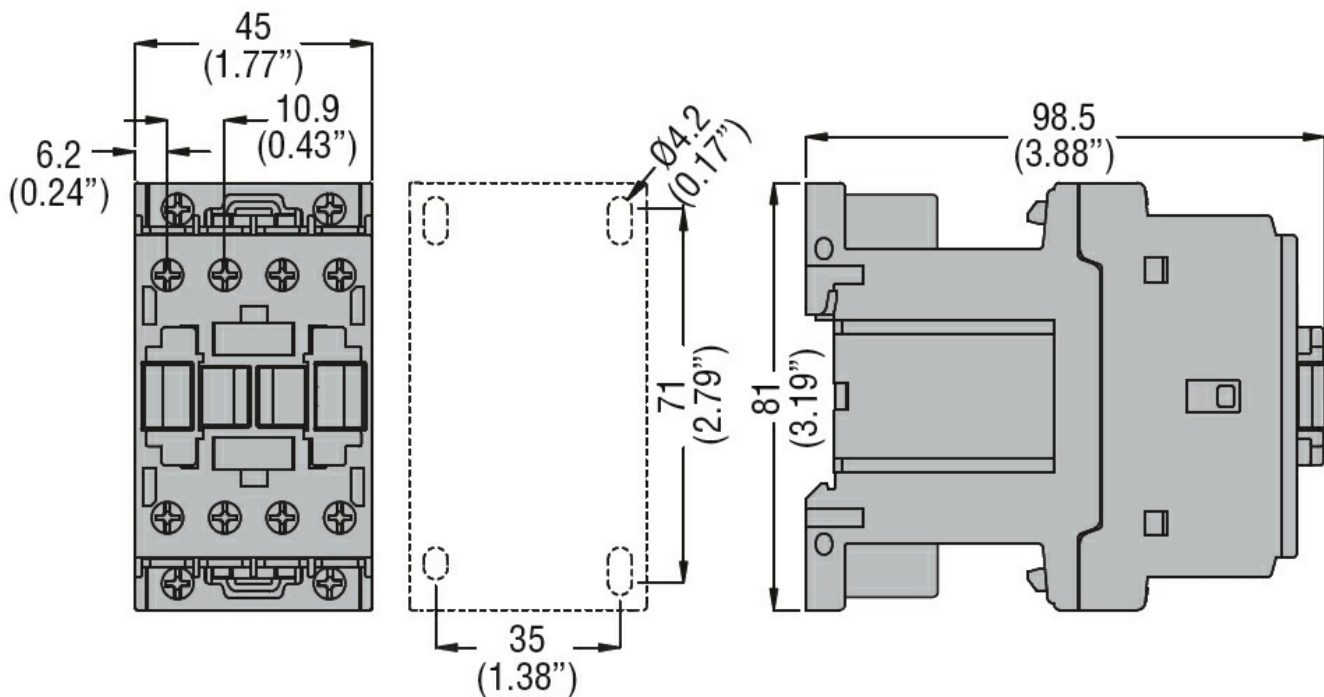

Wiring diagrams

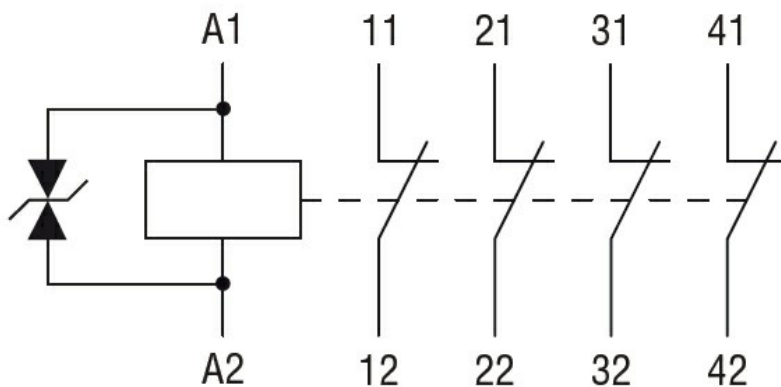

Certifications and compliance

Compliance

- CSA C22.2 n° 60947-1
- CSA C22.2 n° 60947-5-1
- IEC/EN 60947-1
- IEC/EN 60947-5-1
- UL 60947-1

	UL 60947-5-1
Certificates	CCC
	cULus
	EAC

ETIM classification	
ETIM 8.0	EC000196 - Contactor relay