



Contact characteristics

Number of poles	Nr.	4
Rated insulation voltage U _i IEC/EN	V	690
Rated impulse withstand voltage U _{imp}	kV	6
Operational frequency	min	Hz 25
	max	Hz 400
IEC Conventional free air thermal current I _{th} ≤ 40°C	A	32
Operational current I _e	AC-1 (≤40°C)	A 32
	AC-1 (≤55°C)	A 26
	AC-1 (≤70°C)	A 23
	AC-3 (≤440V ≤55°C)	A 18
	AC-4 (400V)	A 8.5
Rated operational power AC-1 (T≤40°C)	230V	kW 12
	400V	kW 21
	500V	kW 26
	690V	kW 36
IEC max current I _e in DC1 with L/R ≤ 1ms with 1 poles in series	≤24V	A 17
	48V	A 15
	75V	A 15
	110V	A 6
	220V	A –
IEC max current I _e in DC1 with L/R ≤ 1ms with 2 poles in series	≤24V	A 20
	48V	A 20
	75V	A 20
	110V	A 13
	220V	A 1
IEC max current I _e in DC1 with L/R ≤ 1ms with 3 poles in series	≤24V	A 22
	48V	A 22
	75V	A 20
	110V	A 16
	220V	A 11
IEC max current I _e in DC1 with L/R ≤ 1ms with 4 poles in series	≤24V	A 22
	48V	A 22
	75V	A 20
	110V	A 18
	220V	A 13
IEC max current I _e in DC3-DC5 with L/R ≤ 15ms with 1 poles in series	≤24V	A 12

	48V	A	11
	75V	A	11
	110V	A	2
	220V	A	–
<hr/>			
IEC max current I _e in DC3-DC5 with L/R ≤ 15ms with 2 poles in series	≤24V	A	15
	48V	A	13
	75V	A	13
	110V	A	8
	220V	A	2
<hr/>			
IEC max current I _e in DC3-DC5 with L/R ≤ 15ms with 3 poles in series	≤24V	A	18
	48V	A	18
	75V	A	16
	110V	A	12
	220V	A	6
<hr/>			
IEC max current I _e in DC3-DC5 with L/R ≤ 15ms with 4 poles in series	≤24V	A	18
	48V	A	18
	75V	A	16
	110V	A	13
	220V	A	8
<hr/>			
Short-time allowable current for 10s (IEC/EN60947-1)		A	200
<hr/>			
Protection fuse	gG (IEC)	A	32
	aM (IEC)	A	20
<hr/>			
Making capacity (RMS value)		A	180
<hr/>			
Breaking capacity at voltage	440V	A	144
	500V	A	120
	690V	A	94
<hr/>			
Resistance per pole (average value)		mΩ	2.5
<hr/>			
Power dissipation per pole (average value)	I _{th}	W	2.6
	AC-3	W	0.8
<hr/>			
Tightening torque for terminals	min	Nm	1.5
	max	Nm	1.8
	min	lbin	1.1
	max	lbin	1.5
<hr/>			
Tightening torque for coil terminal	min	Nm	0.8
	max	Nm	1
	min	lbin	0.8
	max	lbin	0.74
<hr/>			
Max number of wires simultaneously connectable		Nr.	2
<hr/>			
Conductor section	AWG/Kcmil		
	max		10
<hr/>			
Flexible w/o lug conductor section	min	mm ²	1
	max	mm ²	6
<hr/>			
Flexible c/w lug conductor section			

	min	mm ²	1
	max	mm ²	4
Flexible with insulated spade lug conductor section			
	min	mm ²	1
	max	mm ²	6
Power terminal protection according to IEC/EN 60529			IP20 when properly wired
Cable stripping length			
	main circuit	mm	10
	command circuit	mm	8
Mechanical features			
Operating position			
	normal allowable		Vertical plan ±30°
Fixing			Screw / DIN rail 35mm
Weight		g	496
Operations			
Mechanical life		cycles	20000000
Electrical life		cycles	1600000
Safety related data			
Performance level B10d according to EN/ISO 13489-1			
	rated load	cycles	1600000
	mechanical load	cycles	20000000
EMC compatibility			yes
DC coil operating			
DC rated control voltage		V	125
DC operating voltage			
	pick-up		
	min	%Us	70
	max	%Us	125
	drop-out		
	min	%Us	10
	max	%Us	40
Average coil consumption ≤20°C			
	in-rush	W	5.4
	holding	W	5.4
Max cycles frequency			
Mechanical operation		cycles/h	3600
Operating times			
Average time for Us control in AC			
	Closing NO		
	min	ms	8
	max	ms	24
	Opening NO		
	min	ms	10
	max	ms	20
	Closing NC		
	min	ms	14
	max	ms	28
	Opening NC		
	min	ms	7
	max	ms	18

in DC			
Closing NO	min	ms	54
	max	ms	66
Opening NO	min	ms	14
	max	ms	17

UL technical data

Rated operational voltage AC (UL) V 600

Full-load current (FLA) for three-phase AC motor

at 480V	A	14
at 600V	A	17

Yielded mechanical performance

for single-phase AC motor			
110/120V	HP	1	
230V	HP	3	
for three-phase AC motor			
200/208V	HP	5	
220/240V	HP	5	
460/480V	HP	10	
575/600V	HP	15	

General USE

Contactor	AC current	A	32
-----------	------------	---	----

Short-circuit protection fuse, 600V

High fault			
Short circuit current	kA	100	
Fuse rating	A	60	
Fuse class		J	
Standard fault			
Short circuit current	kA	5	
Fuse rating	A	80	

Ambient conditions

Temperature

Operating temperature			
min	°C	-50	
max	°C	70	
Storage temperature			
min	°C	-60	
max	°C	80	
Max altitude	m	3000	

Resistance & Protection

Pollution degree 3

Dimensions

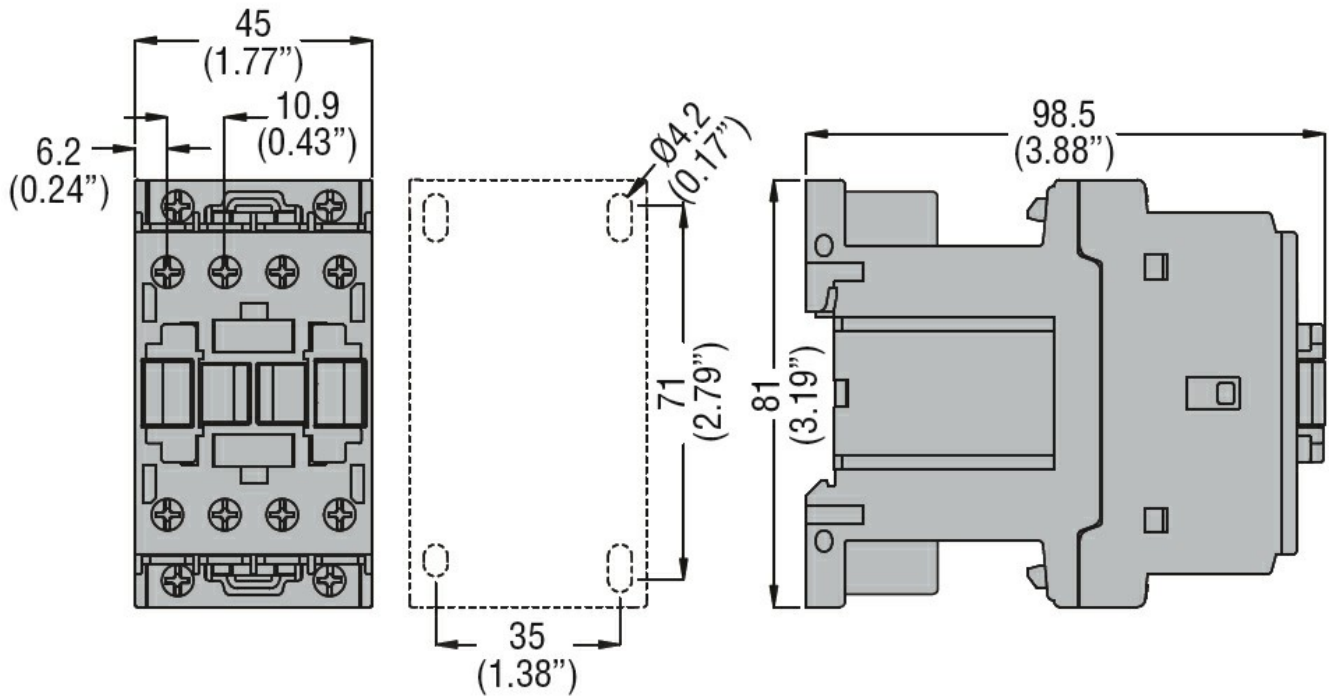

Wiring diagrams

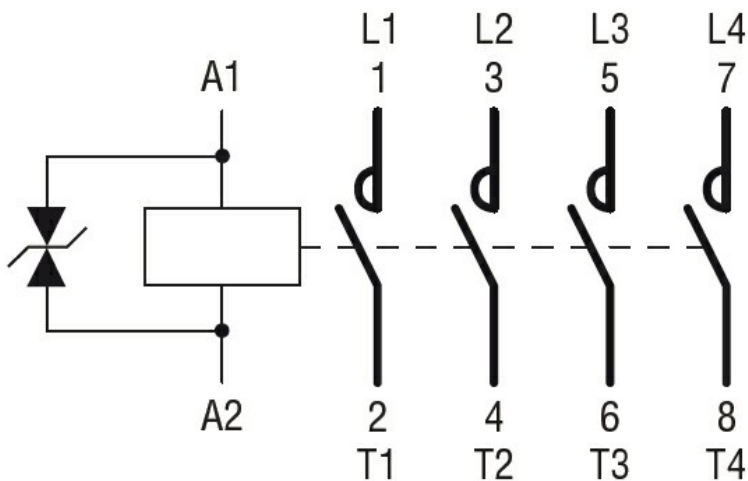

Certifications and compliance

Compliance

CSA C22.2 n° 60947-1
 CSA C22.2 n° 60947-4-1
 IEC/EN 60335-2-89
 IEC/EN/BS 60947-1
 IEC/EN/BS 60947-4-1
 UL 60947-1
 UL 60947-4-1

Certificates

CCC
 CSA C22.2 n. 60335-2-40:22 LZGH A2L
 CSA C22.2 No. 60335-2-89:21 LZGH A2L
 cULus
 EAC
 UL 60335-2-40 LZGH A2L

UL 60335-2-89 LZGH A2L

ETIM classification

ETIM 8.0

EC000066 -
Power contactor,
AC switching