



### Contact characteristics

Number of poles	Nr.	4
Rated insulation voltage $U_i$ IEC/EN	V	690
Rated impulse withstand voltage $U_{imp}$	kV	6
Operational frequency	min	Hz 25
	max	Hz 400
Operational current $I_e$	AC-1 ( $\leq 40^\circ\text{C}$ )	A 20
	AC-1 ( $\leq 55^\circ\text{C}$ )	A 18
	AC-1 ( $\leq 70^\circ\text{C}$ )	A 15
	AC-3 ( $\leq 440\text{V} \leq 55^\circ\text{C}$ )	A 9
	AC-4 (400V)	A 4
Rated operational power AC-1 ( $T \leq 40^\circ\text{C}$ )	230V	kW 8
	400V	kW 14
	500V	kW 16
	690V	kW 22
Short-time allowable current for 10s (IEC/EN60947-1)	A	96
Protection fuse	gG (IEC)	A 20
	aM (IEC)	A 10
Making capacity (RMS value)	A	92
Breaking capacity at voltage	440V	A 72
	500V	A 72
	690V	A 72
Resistance per pole (average value)	m $\Omega$	10
Power dissipation per pole (average value)	$I_{th}$	W 4
	AC-3	W 0.81
Tightening torque for terminals	min	Nm 0.8
	max	Nm 1
	min	lbin 9
	max	lbin 9
Tightening torque for coil terminal	min	Nm 0.8
	max	Nm 1
	min	lbin 9
	max	lbin 9
Max number of wires simultaneously connectable	Nr.	2
Conductor section	AWG/Kcmil	
	max	12

Flexible w/o lug conductor section	min	mm <sup>2</sup>	0.75
	max	mm <sup>2</sup>	2.5
Flexible c/w lug conductor section	min	mm <sup>2</sup>	1.5
	max	mm <sup>2</sup>	2.5
Flexible with insulated spade lug conductor section	min	mm <sup>2</sup>	1.5
	max	mm <sup>2</sup>	2.5
Power terminal protection according to IEC/EN 60529			IP20 when properly wired
<b>Mechanical features</b>			
Operating position	normal allowable		Vertical plan ±30°
Fixing			Screw / DIN rail 35mm
Weight		g	190
<b>Auxiliary contact characteristics</b>			
Thermal current I <sub>th</sub>		A	10
<b>Operations</b>			
Mechanical life		cycles	20000000
Electrical life		cycles	500000
<b>Safety related data</b>			
Performance level B10d according to EN/ISO 13489-1	rated load mechanical load	cycles	500000
		cycles	20000000
EMC compatibility			yes
<b>AC coil operating</b>			
Rated AC voltage at 60Hz		V	575
AC operating voltage			
of 60Hz coil powered at 60Hz			
pick-up	min	%Us	75
	max	%Us	115
drop-out	min	%Us	20
	max	%Us	55
AC average coil consumption at 20°C			
of 50/60Hz coil powered at 50Hz	in-rush holding	VA	30
		VA	4
of 50/60Hz coil powered at 60Hz	in-rush holding	VA	25
		VA	3
of 60Hz coil powered at 60Hz	in-rush holding	VA	30
		VA	4
Dissipation at holding ≤20°C 50Hz		W	0.95
<b>Max cycles frequency</b>			
Mechanical operation		cycles/h	3600
<b>Operating times</b>			
Average time for U <sub>s</sub> control in AC			

Closing NO	min	ms	12
	max	ms	21
Opening NO	min	ms	9
	max	ms	18
Closing NC	min	ms	17
	max	ms	26
Opening NC	min	ms	7
	max	ms	17
<hr/>			
in DC			
Closing NO	min	ms	18
	max	ms	25
Opening NO	min	ms	2
	max	ms	3
Closing NC	min	ms	3
	max	ms	5
Opening NC	min	ms	11
	max	ms	17

**UL technical data**

Rated operational voltage AC (UL)	V	600
Full-load current (FLA) for three-phase AC motor	at 480V	A 7.6
	at 600V	A 6.1

Yielded mechanical performance

for single-phase AC motor

110/120V	HP	0.5
230V	HP	1.5

for three-phase AC motor

200/208V	HP	2
220/240V	HP	3
460/480V	HP	5
575/600V	HP	5

General USE

Contactor

AC current	A	20
------------	---	----

**Ambient conditions**

Temperature

Operating temperature

min	°C	-50
max	°C	+70

Storage temperature

min	°C	-60
max	°C	+80

Max altitude

m	3000
---	------

**Resistance & Protection**

Pollution degree

3

**Dimensions**

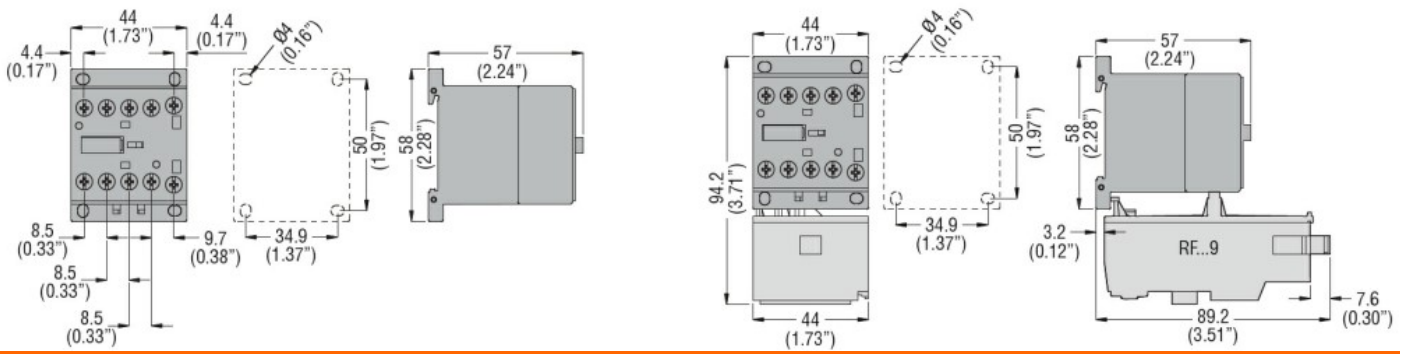

**Wiring diagrams**

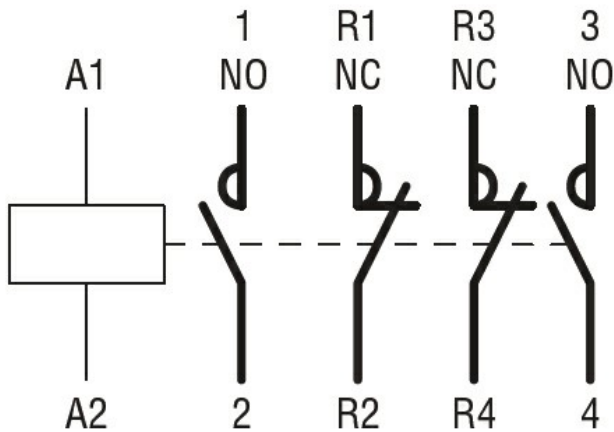

**Certifications and compliance**

**Compliance**

- CSA C22.2 n° 60947-1
- CSA C22.2 n° 60947-4-1
- IEC/EN 60335-2-89
- IEC/EN 60947-1
- IEC/EN 60947-4-1
- UL 60947-1
- UL 60947-4-1

**Certificates**

- CCC
- CSA C22.2 n. 60335-2-40:22 LZGH A2L
- CSA C22.2 No. 60335-2-89:21 LZGH A2L
- cULus
- EAC
- UL 60335-2-40 LZGH A2L
- UL 60335-2-89 LZGH A2L

**ETIM classification**

ETIM 8.0

EC000066 -  
Power contactor,  
AC switching