

SERIE / SERIES: HIGH PROTECTION, HIGH PROTECTION WIRED

BRAND: i-LED

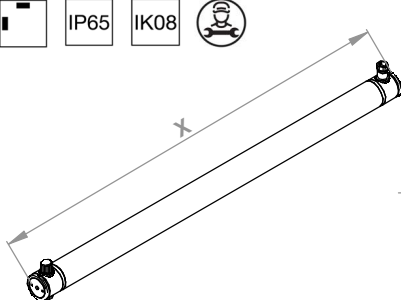
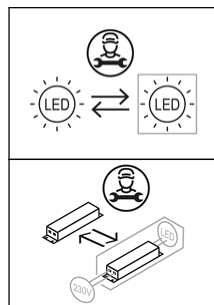
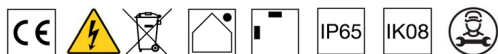

HIGH PROTECTION

A

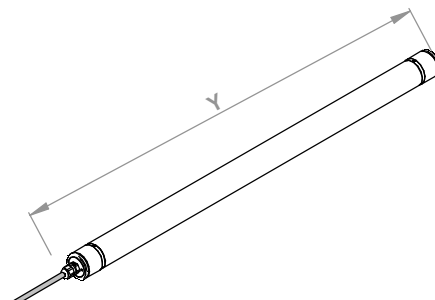
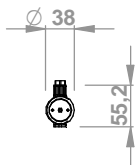

HIGH PROTECTION WIRED

B

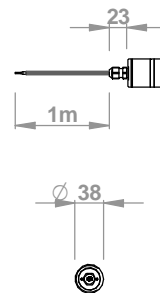

CODICI / CODES

CODE	Dimensions (LxWxH / Ø x H mm)	X [mm]	Y [mm]	Electrical Insulation Class	POWER (W)	VOLTAGE (V)	FREQ. [Hz]	WEIGHT (Kg)	IP	IK	CRI	Energy class light source		No. light source	Conn. Type
												Temperature color LED (°K)			
												3000	4000		
94679	666 x Ø38 x 51	666		2	14,5	220-240	50/60	0,74	66	8	90	E	E	3	Y
84402	666 x Ø38 x 51	666		2	14,5	220-240	50/60	0,74	66	8	90	E	E	3	Y
94680	1276 x Ø38 x 51	1276		2	22	220-240	50/60	1,20	66	8	90	E	E	3	Y
84405	1276 x Ø38 x 51	1276		2	22	220-240	50/60	1,20	66	8	90	E	E	3	Y
94681	1576 x Ø38 x 51	1576		2	35	220-240	50/60	1,50	66	8	90	E	E	4	Y
84408	1576 x Ø38 x 51	1576		2	22	220-240	50/60	1,50	66	8	90	E	E	4	Y
95465	694 x Ø38		694	2	14,5	220-240	50/60	0,82	66	8	90	E	E	3	Y
84411	694 x Ø38		694	2	14,5	220-240	50/60	0,82	66	8	90	E	E	3	Y
95466	1303 x Ø38		1303	2	22	220-240	50/60	1,20	66	8	90	E	E	3	Y
84414	1303 x Ø38		1303	2	22	220-240	50/60	1,20	66	8	90	E	E	3	Y
95467	1605 x Ø38		1605	2	35	220-240	50/60	1,57	66	8	90	E	E	4	Y
84417	1605 x Ø38		1605	2	22	220-240	50/60	1,57	66	8	90	E	E	4	Y

Ta -20°C ÷ 50°C

ACCESSORI INCLUSI / INCLUDED ACCESSORIES

SCATOLA CONNESSIONE IP66
IP66 BOX

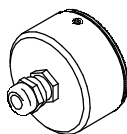

99225 | ON-OFF
83229 | DALI

Cavi Di Alimentazione
Power Cables
230V AC



99216 | 1.5m F. 4pin M12

Cavi Di Estensione Alim.
Power Cables Extensions



99217 | 150mm
99218 | 1500mm F. + M 4pin M12

CAVO DI ESTENSIONE NEOPRENE
NEOPRENE EXTENSION CABLE

99229
ON/OFF | 2x1mm²
83213
DALI | 4x1mm²
83205
DALI | 4x1.5mm²



CAVO DI ESTENSIONE NEOPRENE
NEOPRENE EXTENSION CABLE

98729
ON/OFF
2 POLI / PINS
99768
DALI
5 POLI / PINS

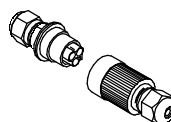

KIT FISSAGGIO A
SOSPENSIONE CON CAVO IN
ACCIAIO DI LUNGHEZZA 1.2m
ALLUMINIO ANODIZZATO
SUSPENSION MOUNTING KIT
WITH 2m STEEL CABLE
ANODIZED ALUMINIUM



99219

KIT FISSAGGIO A
SOSPENSIONE CON CAVO
IN ACCIAIO DI LUNGHEZZA
2m
SUSPENSION MOUNTING
KIT WITH 2m STEEL
CABLE



C-F100017

RACCORDO IN ALLUMINIO
ANODIZZATO
DA USARE SOLO CON 99219
ANODIZED ALUMINIUM JOINT
TO USE ONLY WITH 99219



99219

KIT FISSAGGIO A PLAFONE SERRAGGIO A
VITE IN POLICARBONATO
POLYCARBONATE CEILING MOUNTING
KIT WITH SCREW-TYPE FASTENING

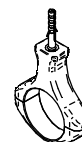

99222

SERIE / SERIES: HIGH PROTECTION, HIGH PROTECTION WIRED

BRAND: i-L^èD

KIT FISSAGGIO A CLIP
ACCIAIO NIKELATO
NICKEL-PLATED STEEL
CLIP MOUNTING KIT



99220

KIT FISSAGGIO A CLIP
POLICARBONATO
POLYCARBONATE CLIP
MOUNTING KIT



99238

STAFFE ANGOLARI
CORNER BRACKET

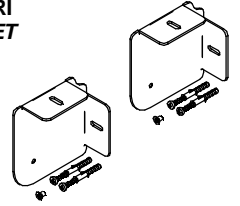

99224

STAFFE INSTALLAZIONE A MURO
WALL BRACKETS

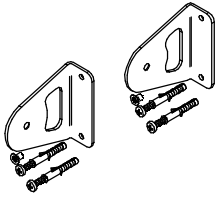

99220

INSTALLAZIONE / INSTALLATION / 99219

A
B
1.A

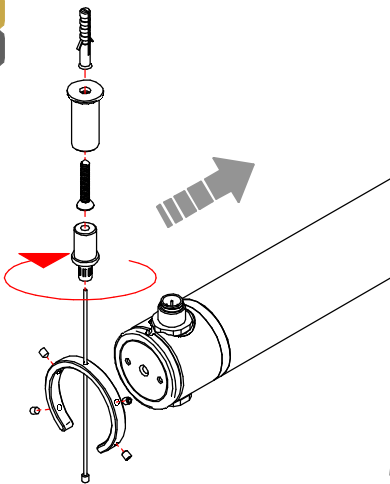

A
B
2.A

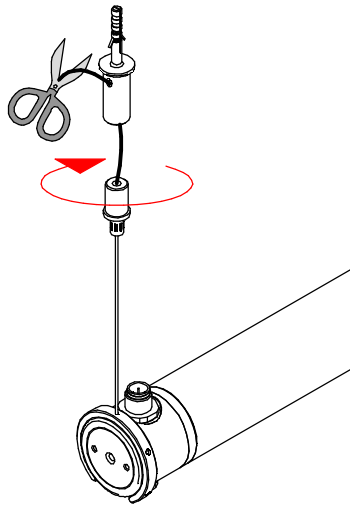

A
B
3.A

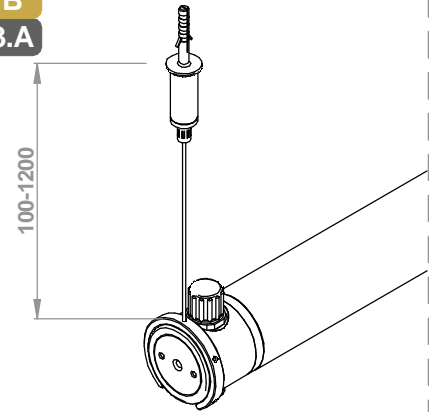

INSTALLAZIONE / INSTALLATION / C-F100017

A
B
1.B

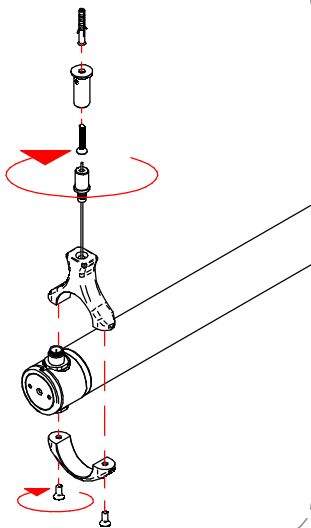

A
B
2.B

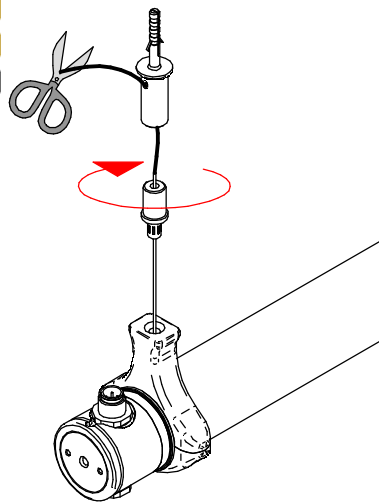

A
B
3.B

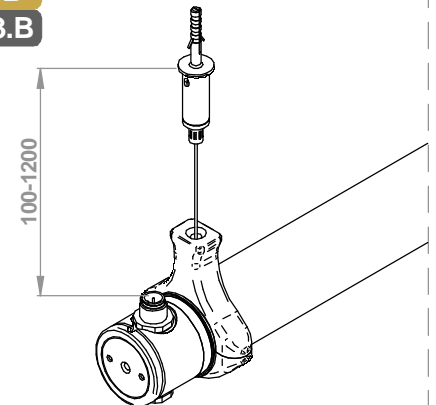

SERIE / SERIES: HIGH PROTECTION, HIGH PROTECTION WIRED

BRAND: i-LED

INSTALLAZIONE / INSTALLATION / 99222

A
B
1.C

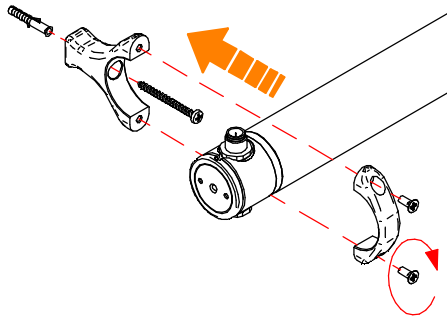

A
B
2.C

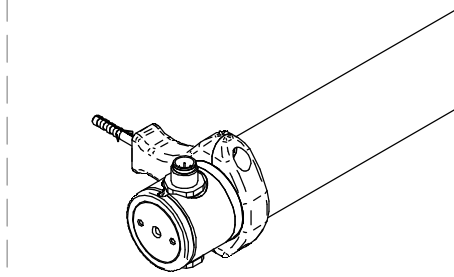

INSTALLAZIONE / INSTALLATION / 99220 99238

A
B
1.D

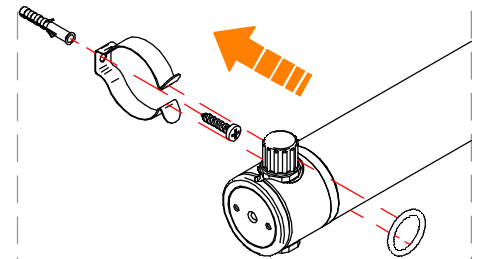

A
B
2.D

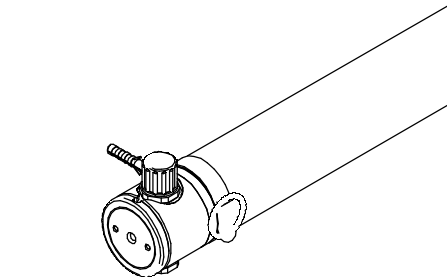

INSTALLAZIONE / INSTALLATION / 99219

A
1.E

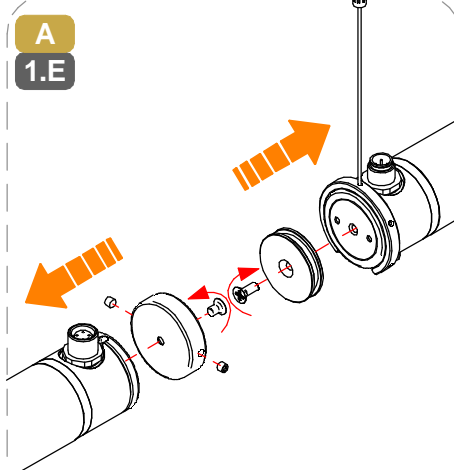

A
2.E

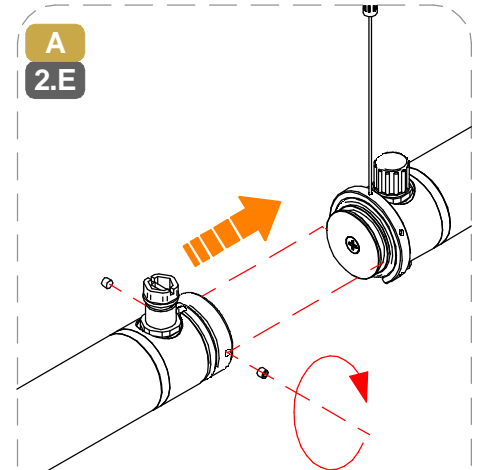

A
3.E

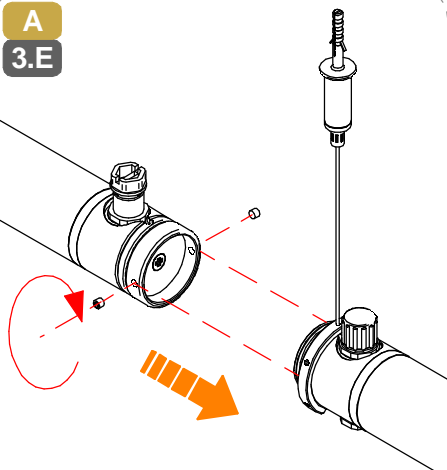

A
4.E

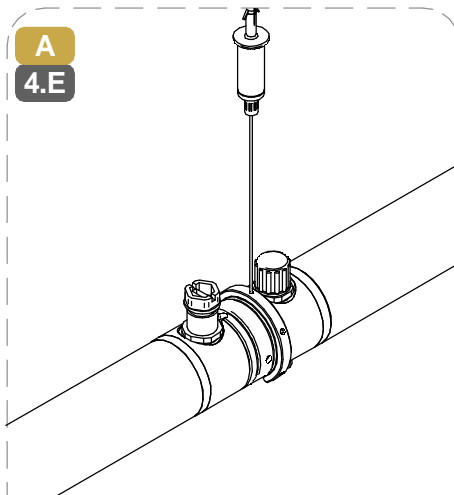

INSTALLAZIONE / INSTALLATION / 99224

A
1.F

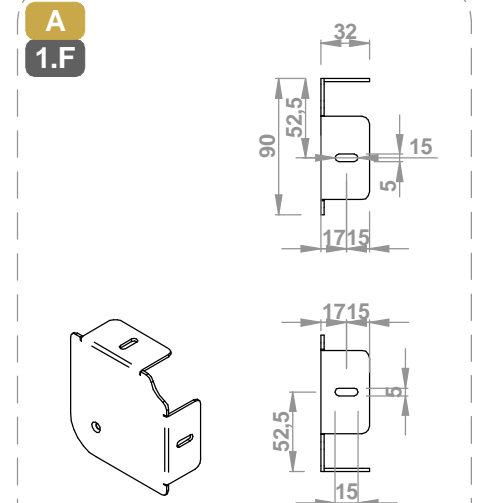

SERIE / SERIES: HIGH PROTECTION, HIGH PROTECTION WIRED

BRAND: i-L^eD

INSTALLAZIONE / INSTALLATION

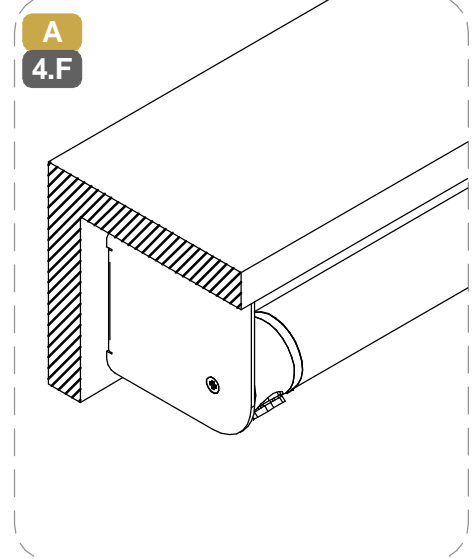
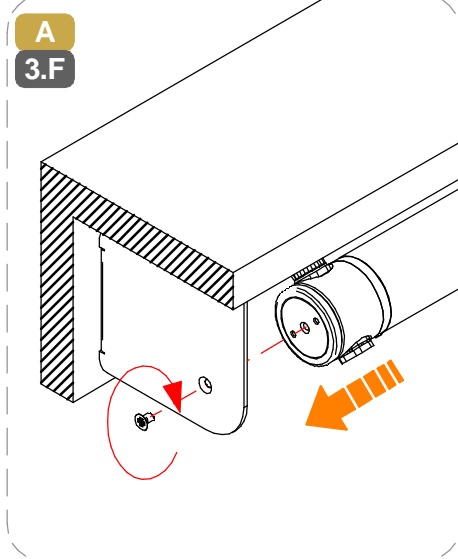
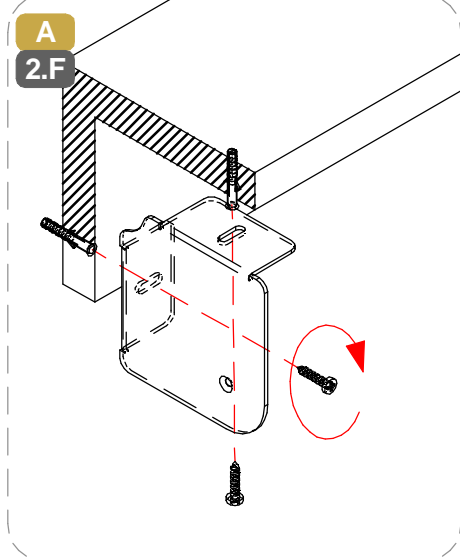

INSTALLAZIONE / INSTALLATION / 99220

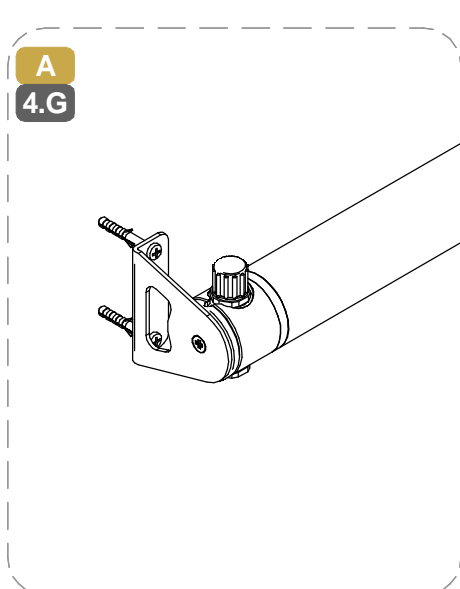
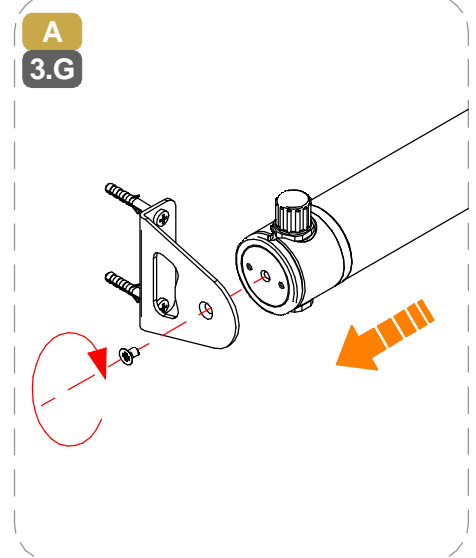
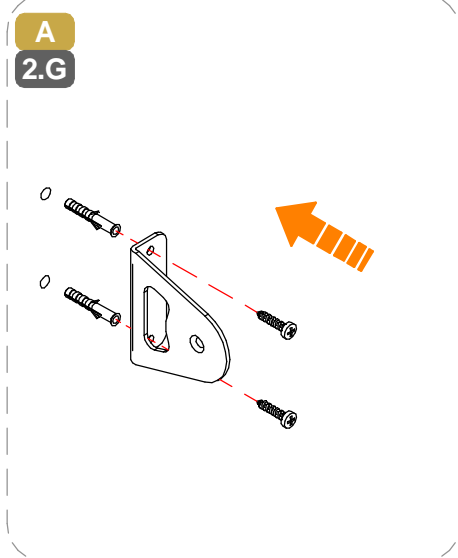
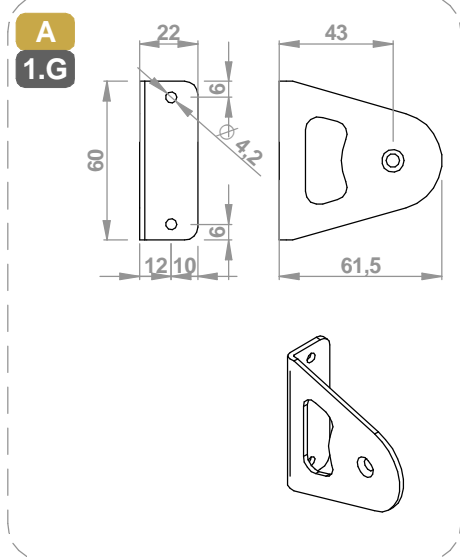

INSTALLAZIONE / INSTALLATION / 99225

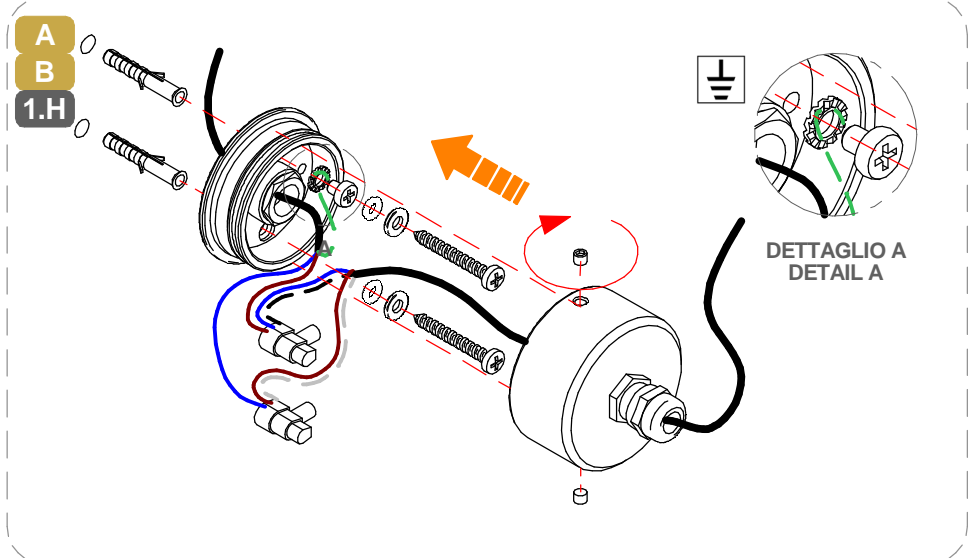

SERIE / SERIES: HIGH PROTECTION, HIGH PROTECTION WIRED

BRAND: i-LED

MARRONE / BROWN = LINEA / LINE

AZZURRO / LIGHT BLUE = NEUTRO / NEUTRAL

GIALLO-VERDE / YELLOW-GREEN = TERRA / EARTH CPC | PE

INSTALLAZIONE / INSTALLATION / 83229

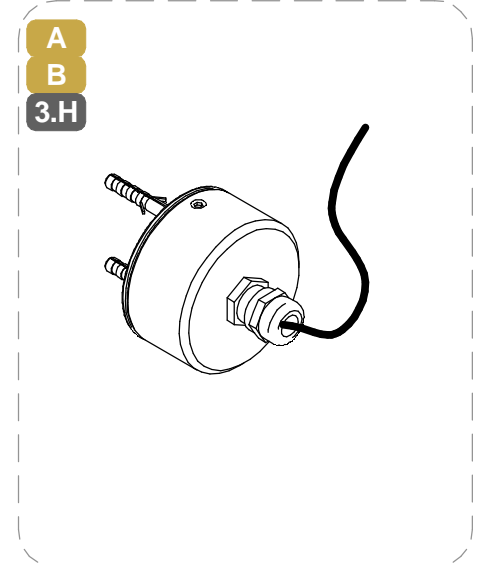
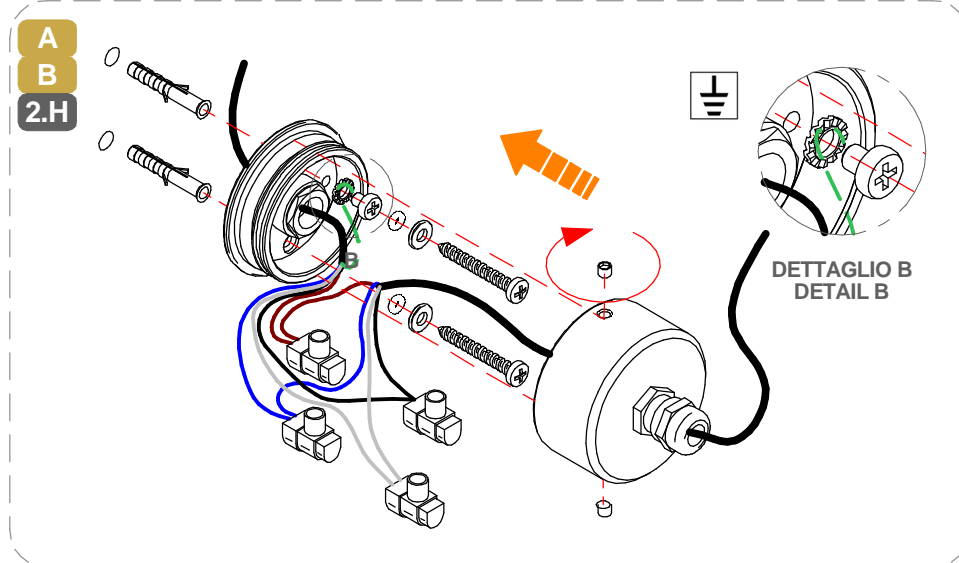

PER L'INSTALLAZIONE SONO
NECESSARI 2 KIT DI
FISSAGGIO

**2 MOUNTING KITS ARE
REQUIRED FOR INSTALLATION**

CABLAGGIO / WIRING

1

TUTTE LE OPERAZIONI DI COLLEGAMENTO ALLA RETE ELETTRICA DEVONO ESSERE CONDOTTE IN MANCANZA DI TENSIONE

ALL THE WIRING OPERATION MUST BE PERFORMED WITH MCB IN OFF POSITION

2

SE IL PRODOTTO E' DEFINITO IN CLASSE 1, IL CONDUTTORE DI MESSA A TERRA DI PROTEZIONE DEVE ESSERE SEMPRE COLLEGATO

IF THE FITTING IS CLASS 1 RATED, THE CPC / EARTH | PE CONDUCTOR MUST BE CONNECTED

3

SE L'IMPIANTO E' STATO COMPLETATO ED E' IN SICUREZZA, PUO' ESSERE ALIMENTATO

WHEN THE CIRCUIT IS COMPLETED AND SAFE, MCB CAN BE SET IN ON POSITION

TIPO DI CONNESSIONE
TYPE OF CONNECTION

X: Se il cavo flessibile esterno di questo apparecchio è danneggiato, deve essere sostituito da un cavo speciale, disponibile esclusivamente presso il fabbricante, o il suo servizio di assistenza.

X: If the external flexible cable of this appliance is damaged, it must be replaced with a special cable, which is only available from the manufacturer or its service department.

Y: Se il cavo flessibile esterno di questo apparecchio è danneggiato, deve essere sostituito esclusivamente dal fabbricante, dal suo servizio di assistenza o da personale qualificato equivalente, al fine di evitare pericoli.

Y: If the external flexible cable of this appliance is damaged, it must only be replaced by the manufacturer, its service department or equivalent qualified personell in order to avoid danger.

Z: Il cavo flessibile esterno di questo apparecchio non può essere sostituito; se il cavo è danneggiato l'apparecchio deve essere distrutto.

Z: The external flexible cable fo this appliance cannot be replaced; if the cable is damaged, the appliance must be destroyed.

CABLAGGIO IN PARALLELO | PARALLEL WIRING
TENSIONE DI RETE | MAINS VOLTAGE

AC

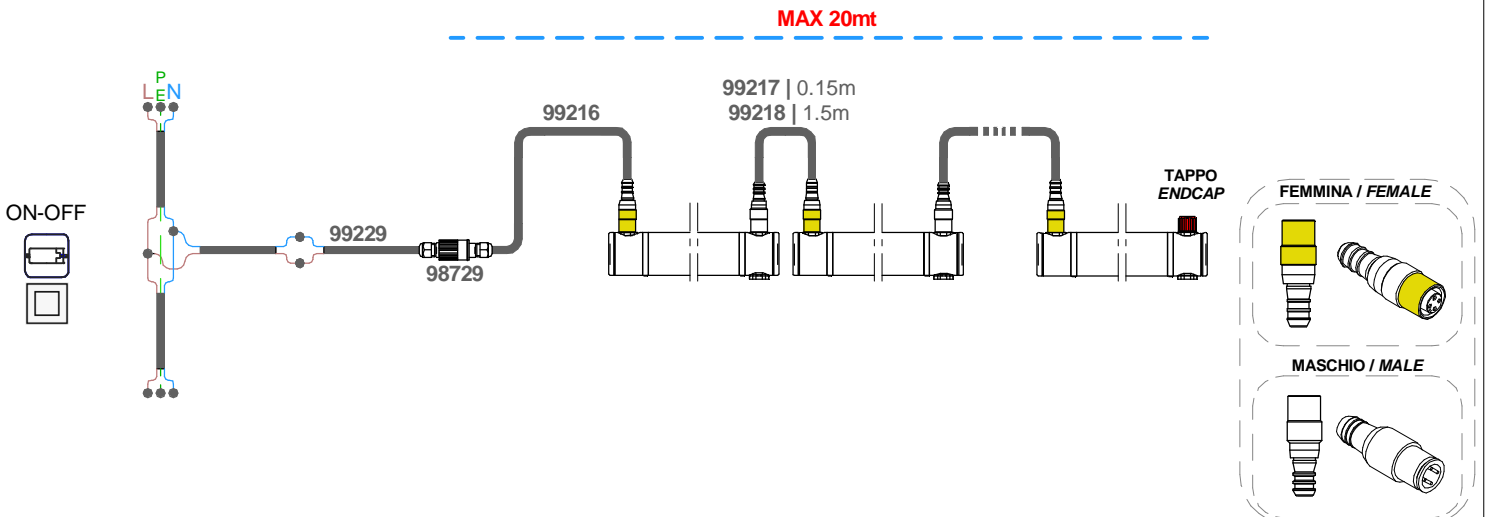

SERIE / SERIES: HIGH PROTECTION, HIGH PROTECTION WIRED

BRAND: i-LèD

MARRONE / BROWN = LINEA / LINE

AZZURRO / LIGHT BLUE = NEUTRO / NEUTRAL

GIALLO-VERDE / YELLOW-GREEN = TERRA / EARTH CPC | PE

**CABLAGGIO IN PARALLELO | PARALLEL WIRING
TENSIONE DI RETE / MAINS VOLTAGE**

AC

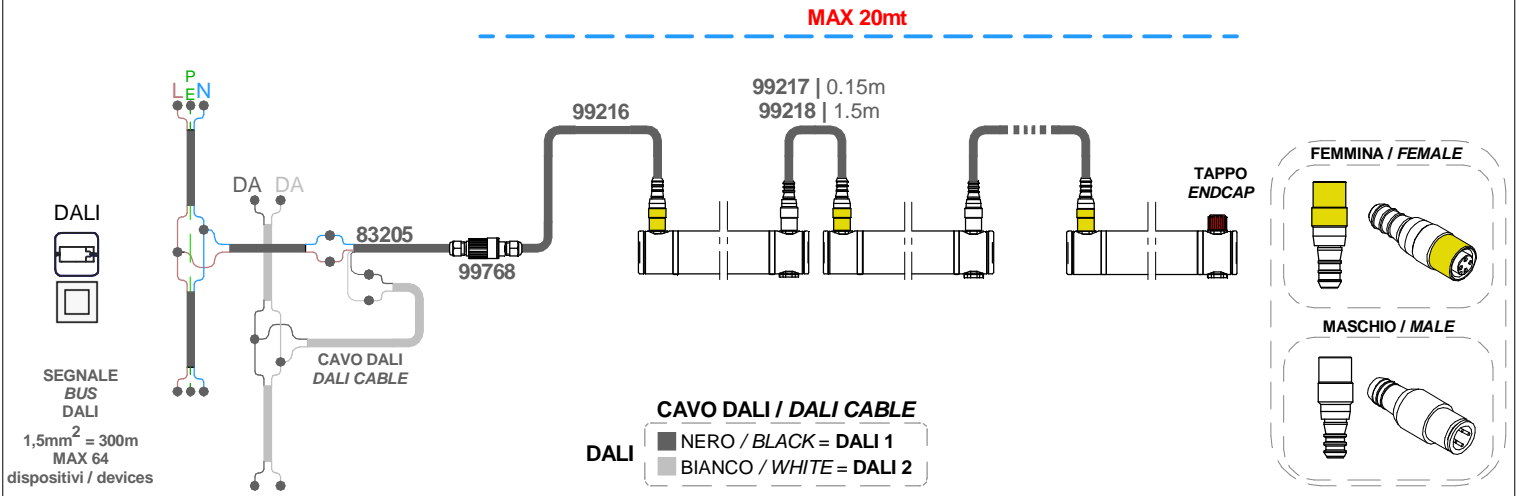

**CABLAGGIO IN PARALLELO | PARALLEL WIRING
TENSIONE DI RETE / MAINS VOLTAGE**

AC

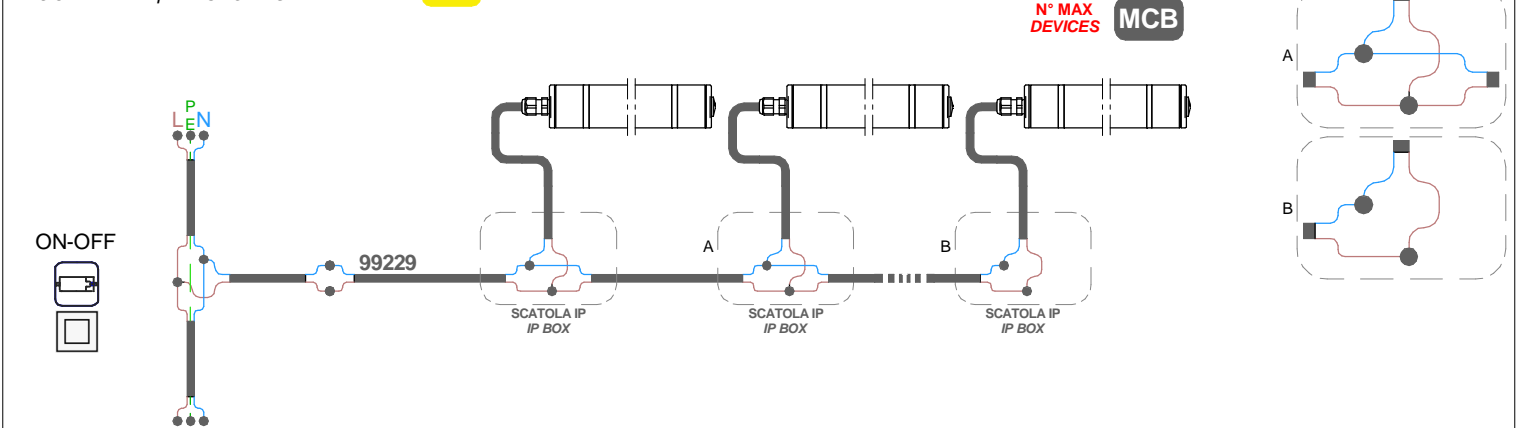

**CABLAGGIO IN PARALLELO | PARALLEL WIRING
TENSIONE DI RETE / MAINS VOLTAGE**

AC

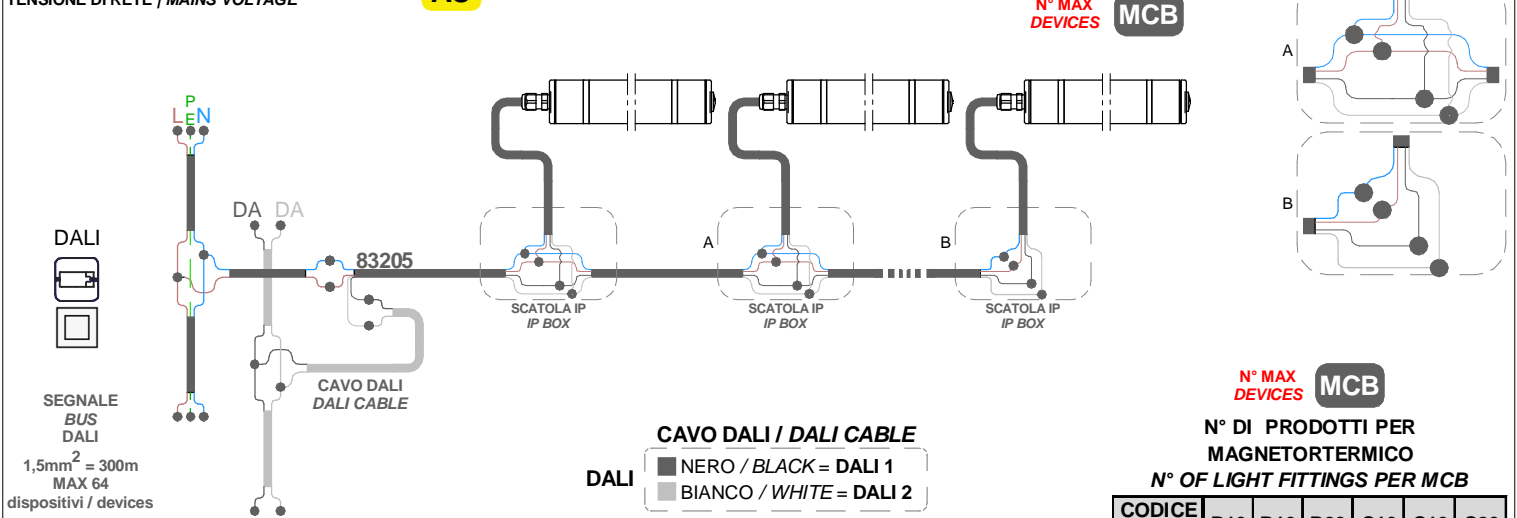

N° MAX DEVICES MCB

**N° DI PRODOTTI PER
MAGNETOTERMICO**

N° OF LIGHT FITTINGS PER MCB

CODICE CODE	B10	B16	B20	C10	C16	C20
95465	27	44	55	32	51	64
84411	44	70	88	51	82	102
95466	27	44	55	32	51	64
84414	44	70	88	51	82	102
95467	27	44	55	32	51	64
84417	44	70	88	51	82	102