

300x300 UPS

- CA027KWHWDI 3000K
- CA027KWHMDI 2700K
- CA027KBBWDI 3000K
- CA027KBBMDI 2700K

400x400 UPS

- CA028KWHWDI 3000K
- CA028KWHMDI 2700K
- CA028KBBWDI 3000K
- CA028KBBMDI 2700K

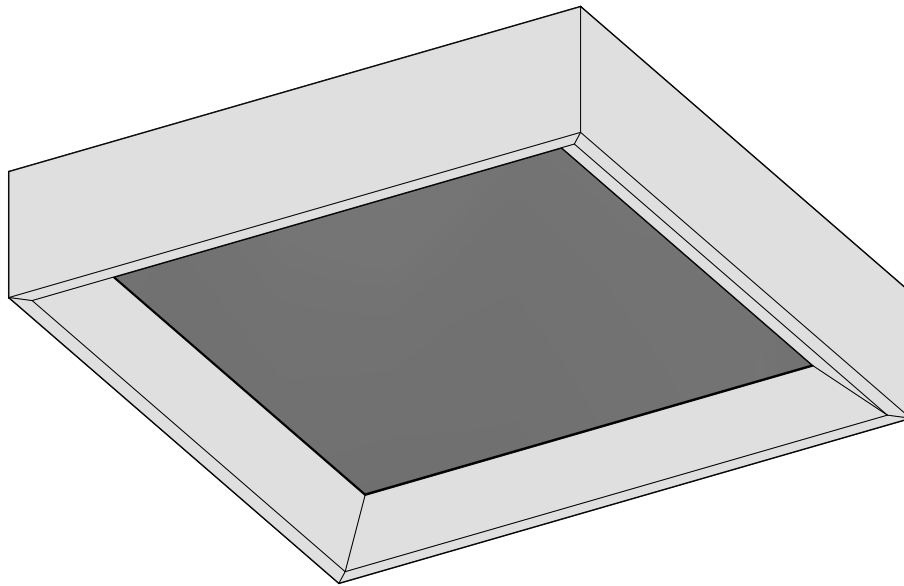

APPARECCHIO PER COLLEGAMENTO A RETE ELETTRICA DEDICATA  
INSTALLAZIONE E REGOLAZIONE ESEGUITA SOLO DA PERSONALE  
QUALIFICATO

APPLIANCE FOR CONNECTION TO DEDICATED POWER SUPPLY  
INSTALLATION AND ADJUSTMENT PERFORMED ONLY BY  
QUALIFIED STAFF

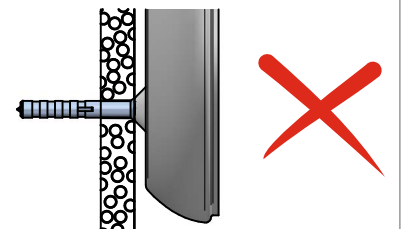
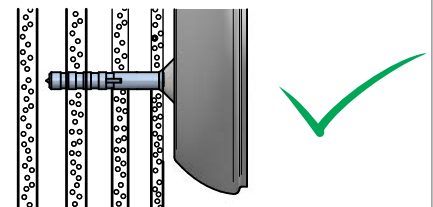
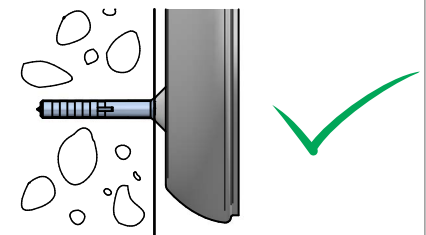
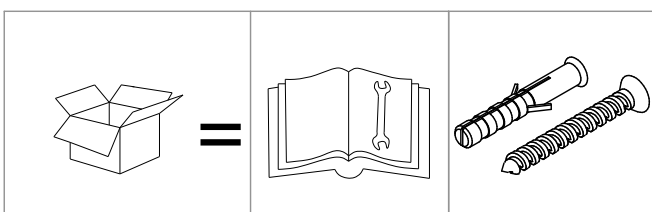
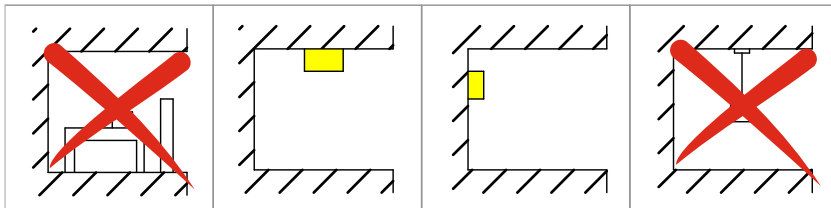
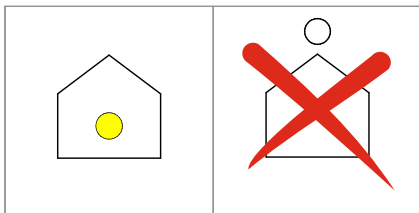

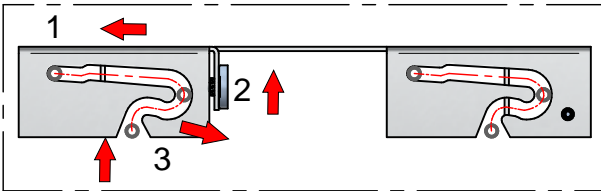
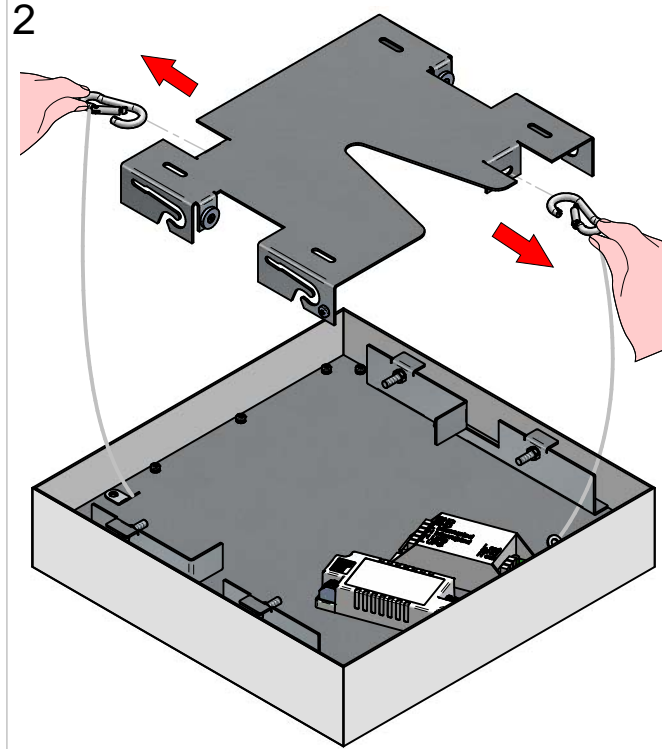
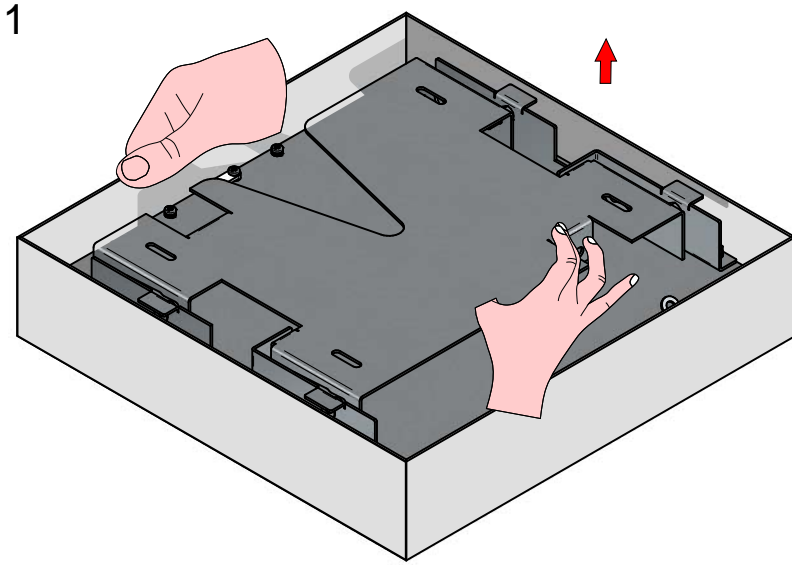

3.1

300x300 UPS

- CA027KWHWDI 3000K
- CA027KWHMDI 2700K
- CA027KBBWDI 3000K
- CA027KBBMDI 2700K

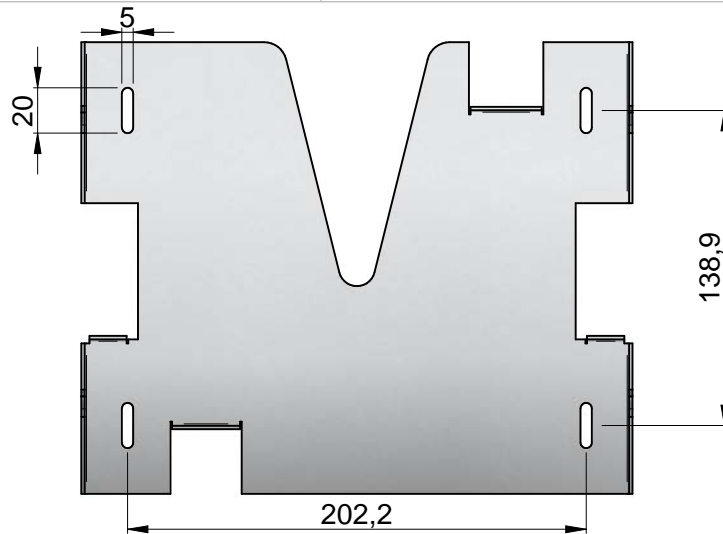

3.2

400x400 UPS

- CA028KWHWDI 3000K
- CA028KWHMDI 2700K
- CA028KBBWDI 3000K
- CA028KBBMDI 2700K

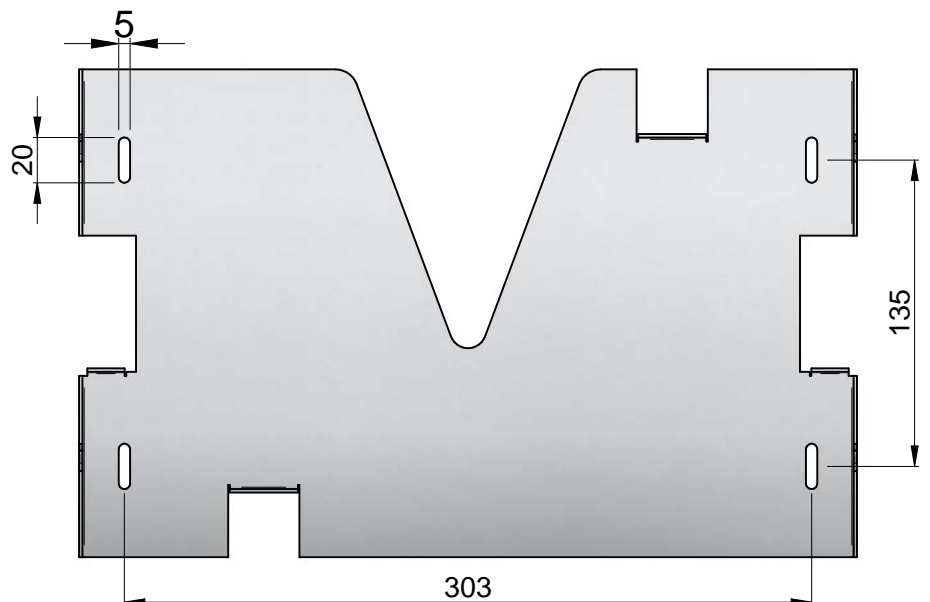

4

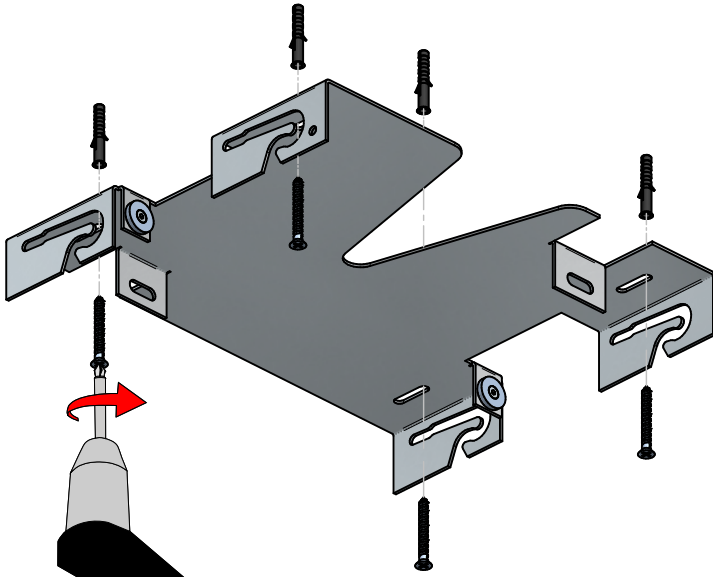

5

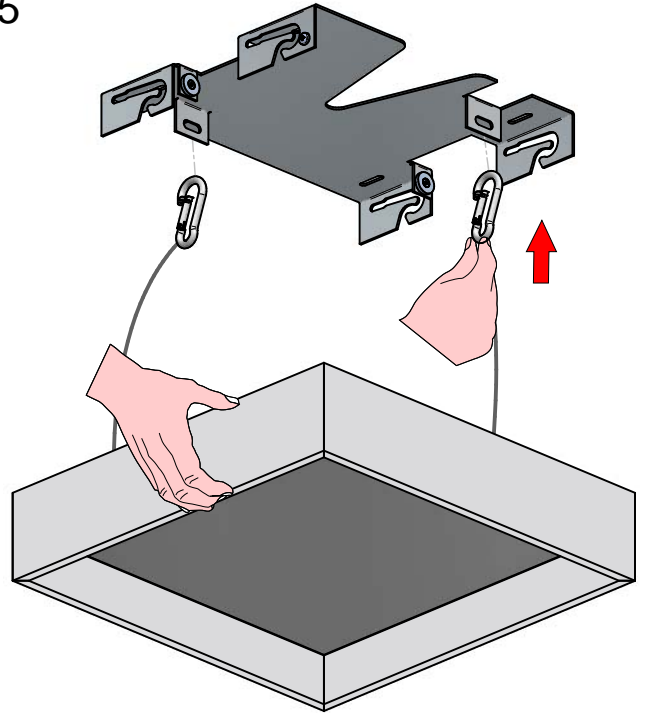

Commutatore

Driver EL

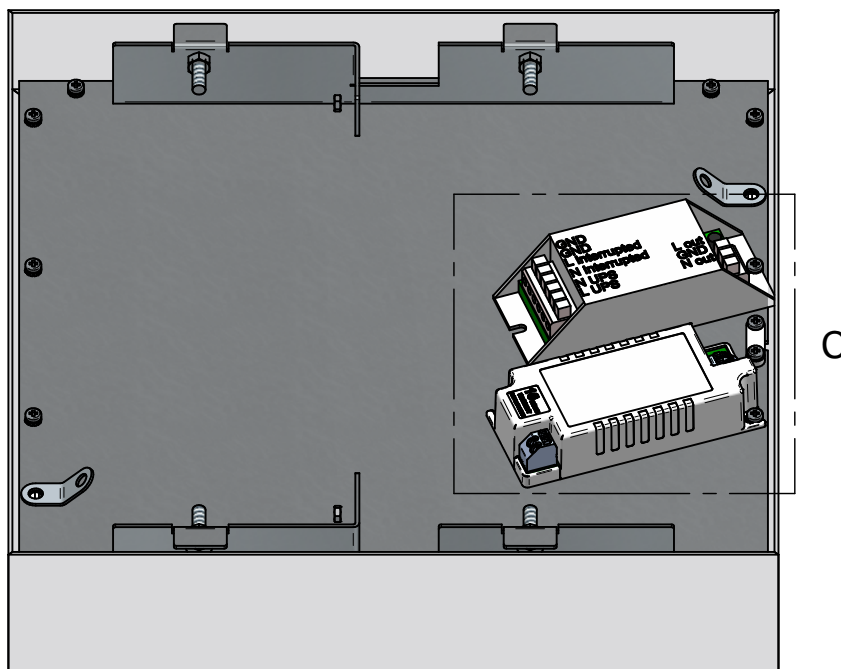
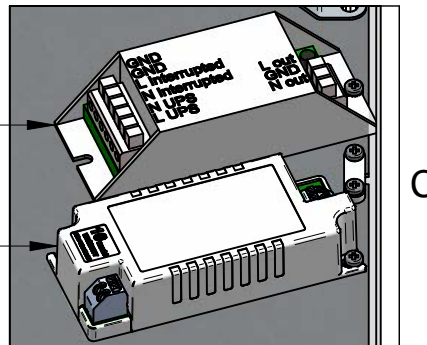

LE/NE  
APPARECCHIO DI EMERGENZA PER  
ALIMENTAZIONE CENTRALIZZATA CON  
LINEA DEDICATA "EM" UPS/CPS  
220V 0...50/60Hz

LE/NE  
EMERGENCY DEVICE FOR  
CENTRALIZED POWER SUPPLY WITH  
DEDICATED LINE "EM" UPS/CPS  
220V 0...50/60Hz

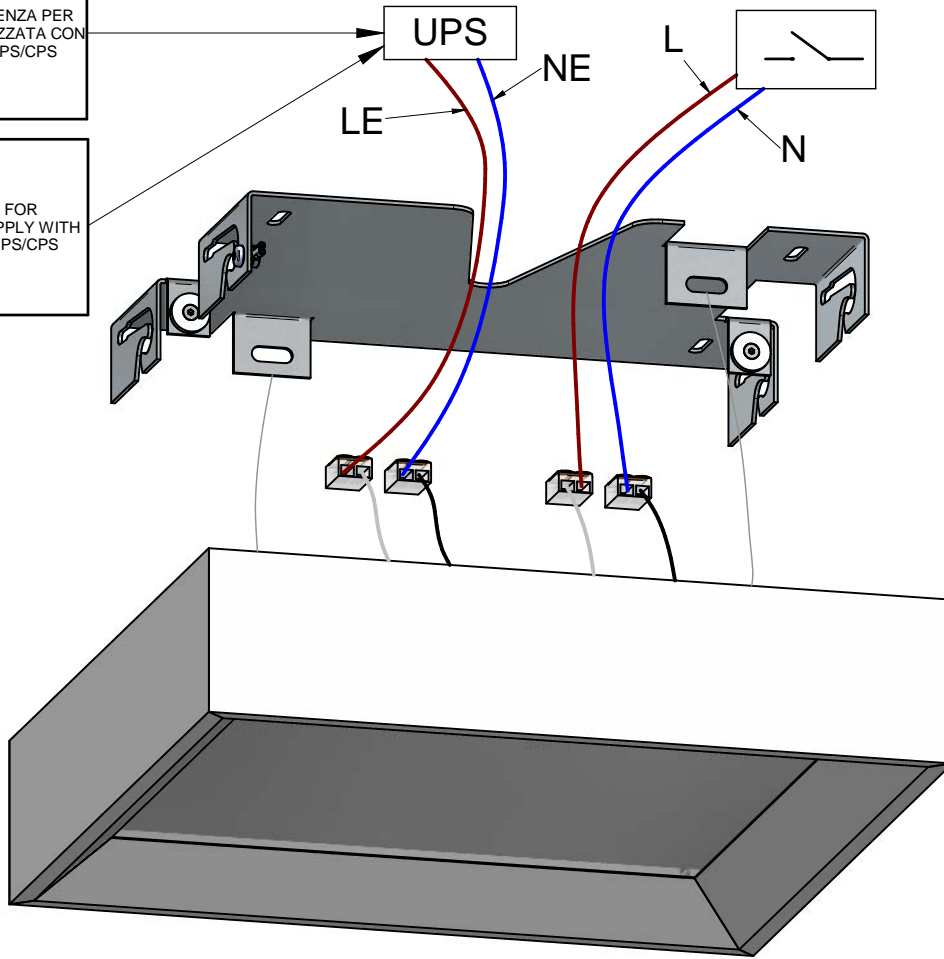

Cavo terra della staffa  
Land Bracket

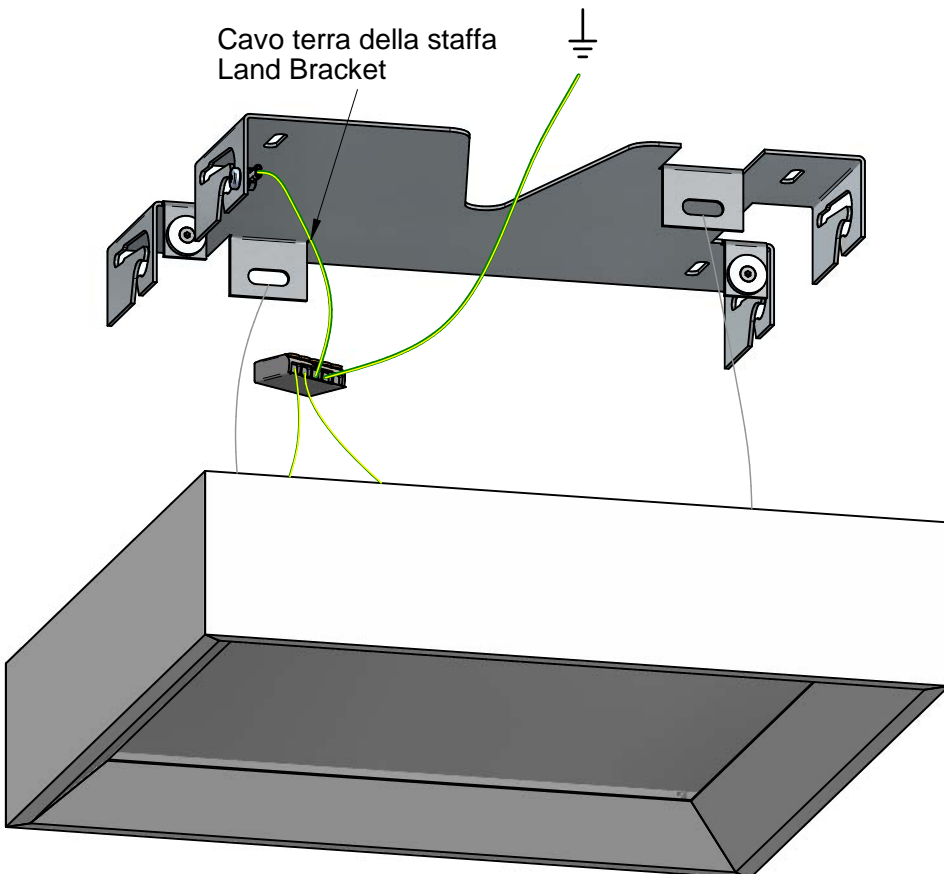



Fill in the label with the missing data, then attach it to the outside of the lamp, it must be visible

## English

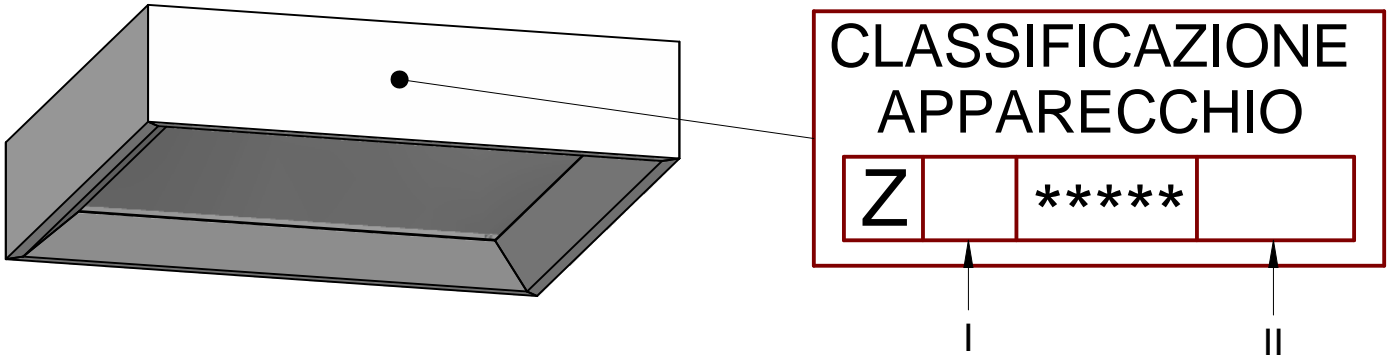

I. How it works (Fill in with a single digit):

1. **Permanent:** device with a light source that functions both in the presence and absence of ordinary power supply;
2. **Not Permanent:** device with a light source that only functions in the event of a failure to provide ordinary power;
3. **Permanent combined:** appliance with two or more light sources operating via ordinary power supply where at least one source is operational in the event of failure of ordinary power supply.
4. **Combined not permanent:** appliance with two or more light sources where at least one source is functional only in the event of a failure of the ordinary power supply.

II. Duration in emergency (Fill in with two-three characters, always expressed in minutes):

- 10 min;
- 60 min;
- 120 min;
- 1... ;

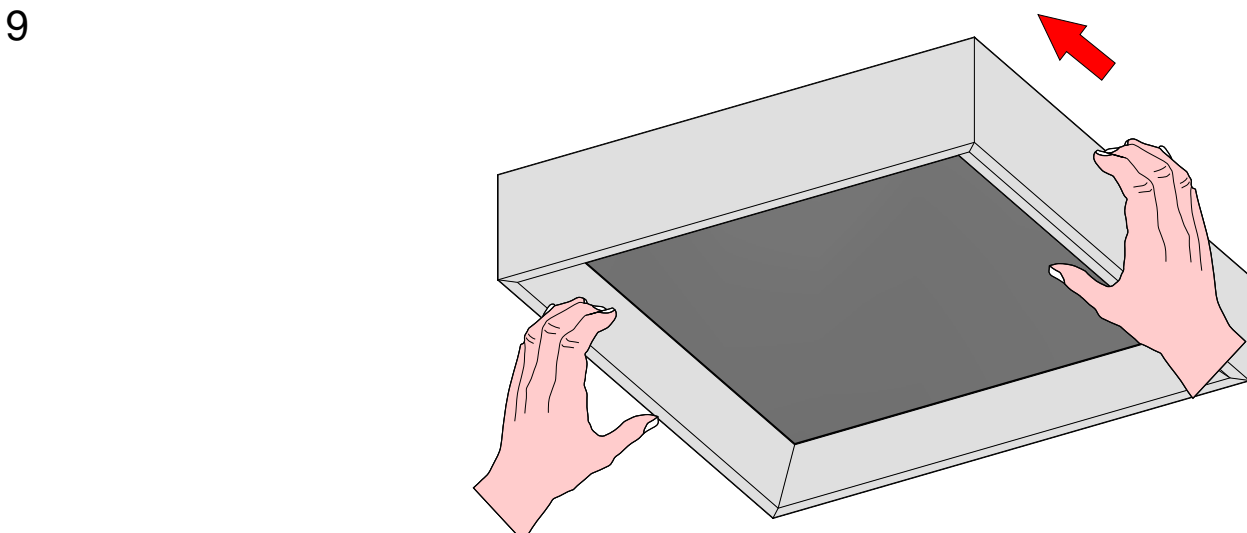
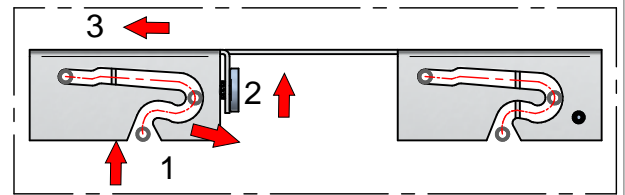
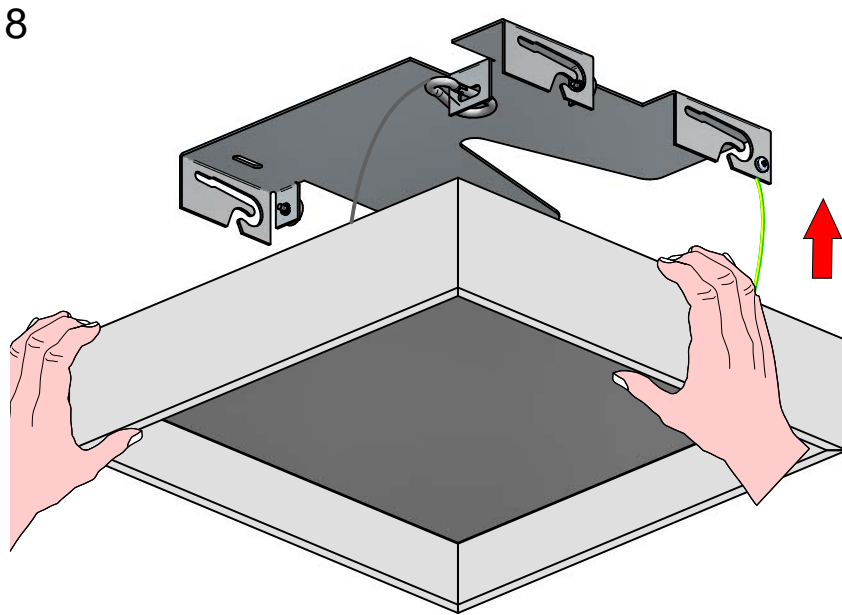
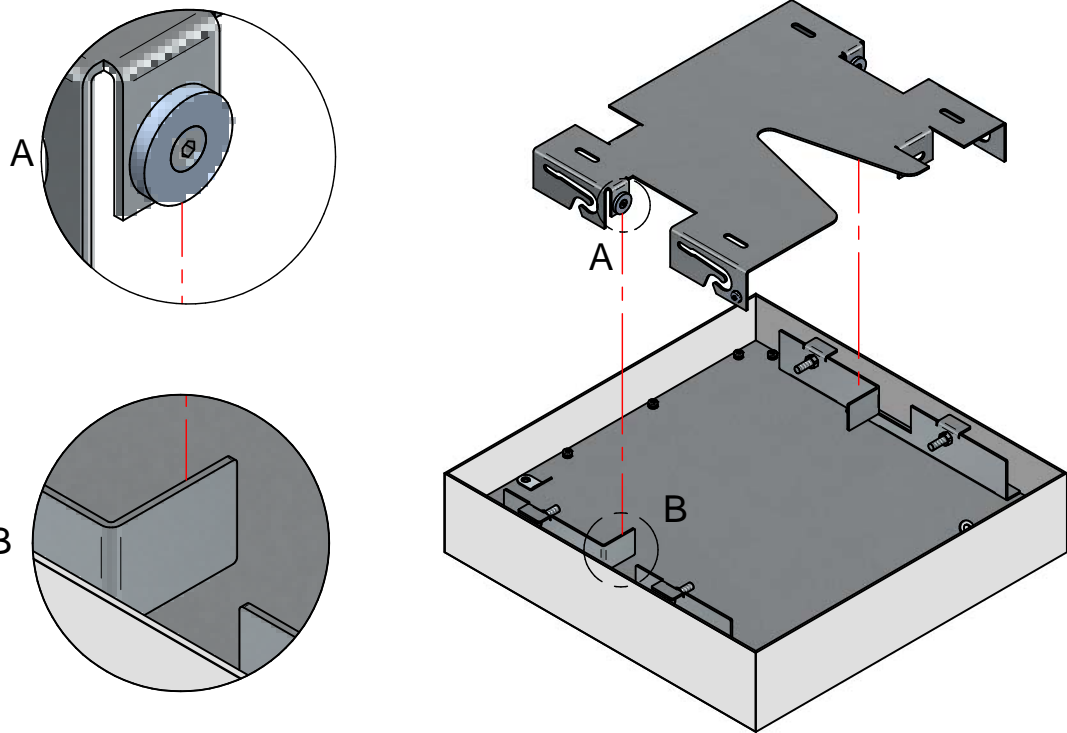

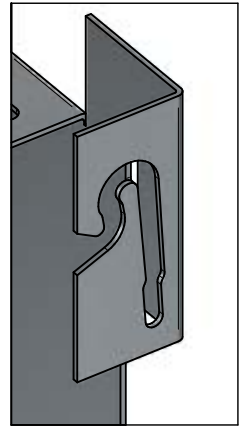
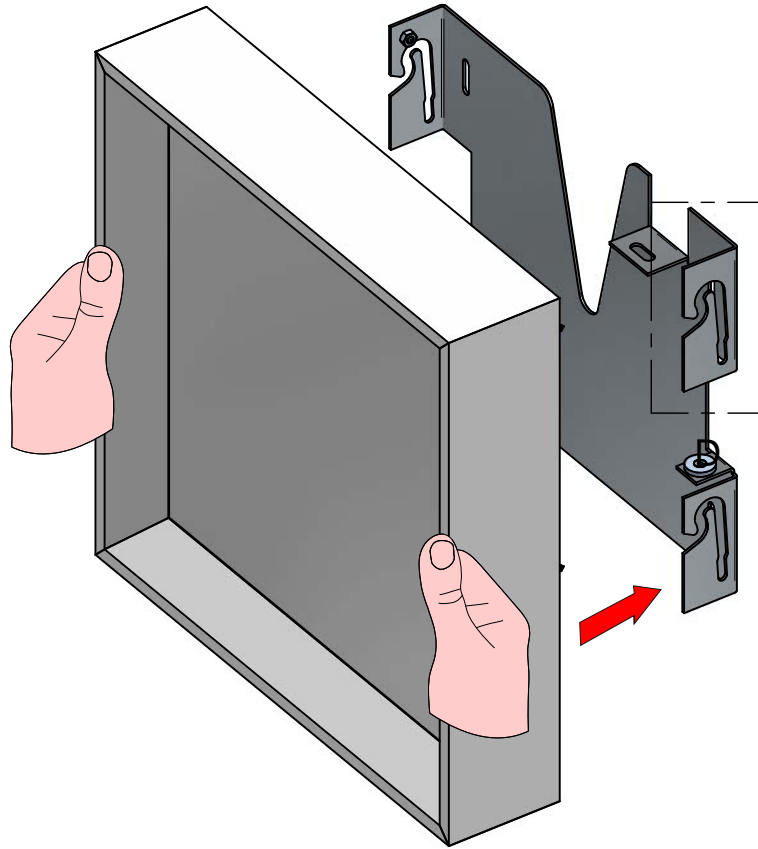
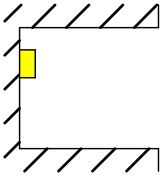

D

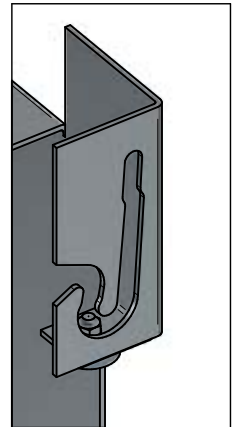
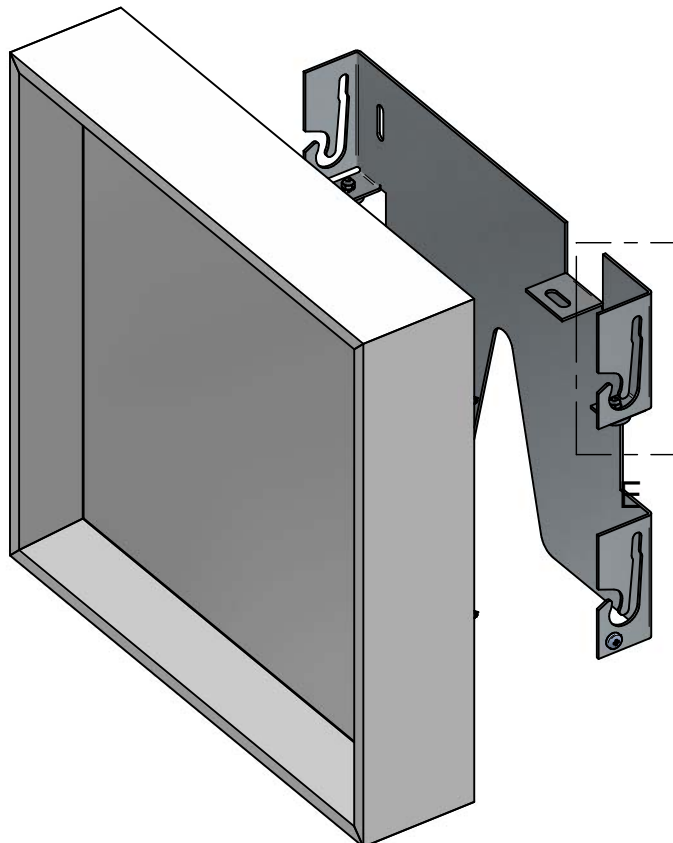

E



**ISTRUZIONI PER IL LAVAGGIO DELL'APPARECCHIO D'ILLUMINAZIONE**  
**LUMINAIRE CARE INSTRUCTIONS**  
**ISTRUCCIONES PARA LIMPIAR LA LUMINARA**  
**INSTRUCTIONS POUR LE LAVAGE DE L'APPAREIL D'ECLAIRAGE**  
**ANLEITUNG ZUR REINIGUNG DES BELEUCHTUNGSGERATS**

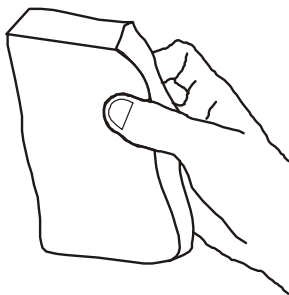
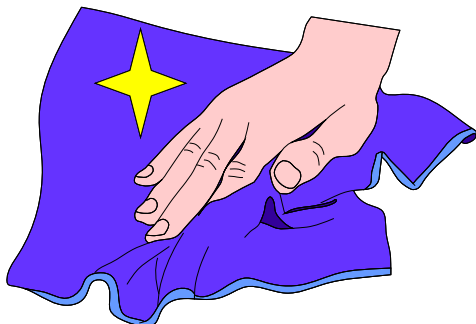

**IT - ATTENZIONE!!!**

Lavare la superficie del diffusore luce con panno umido, utilizzando solo acqua e sapone neutro.

**EN - WARNING!!!**

Wipe clean with a cloth damped in water with neutral detergent.

**ES - ATENCION!!!**

Limpie la superficie del difusor con un pano humedecido con agua y jabon neutro.

**FR - ATTENTION!!!**

Laver la surface du diffuseur de lumiere a l'aide d'un chiffon humide et en utilisant seulement de l'eau et du savon neutre.

**DE - ACHTUNG!!!**

Die oberfläche vom lampenschirm mit einem feuchten lappen reinigen. De lappen mit wasser und neutralseife befeuchten.

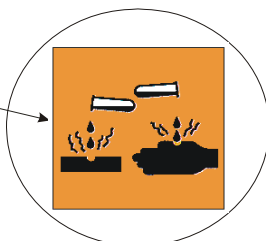
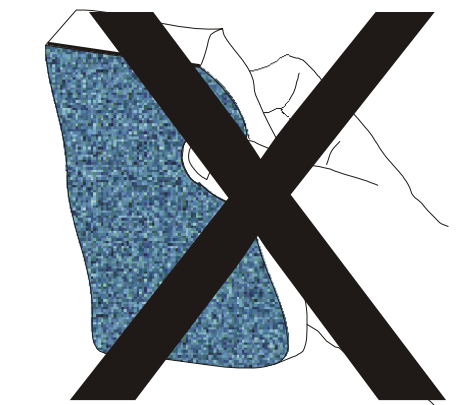

**IT - ATTENZIONE!!!**

Non utilizzare panni abrasivi e/o solventi.

**EN - WARNING!!!**

Avoiding the use of chemical solvents and/or abrasive cloths.

**ES - ATENCION!!!**

No utilizar panos abrasivos y solventes.

**FR - ATTENTION!!!**

Ne pas utiliser de chiffons abrasifs ou de dissolvants.

**DE - ACHTUNG!!!**

Abschleifende tuche und/oder losungsmittel nicht benutzen.