

SERIES/SERIES: SHAKER | CLARK 316

BRAND: i-LED

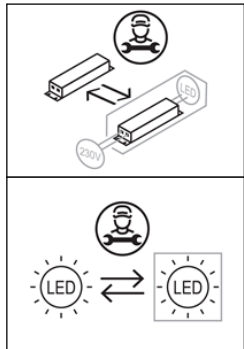
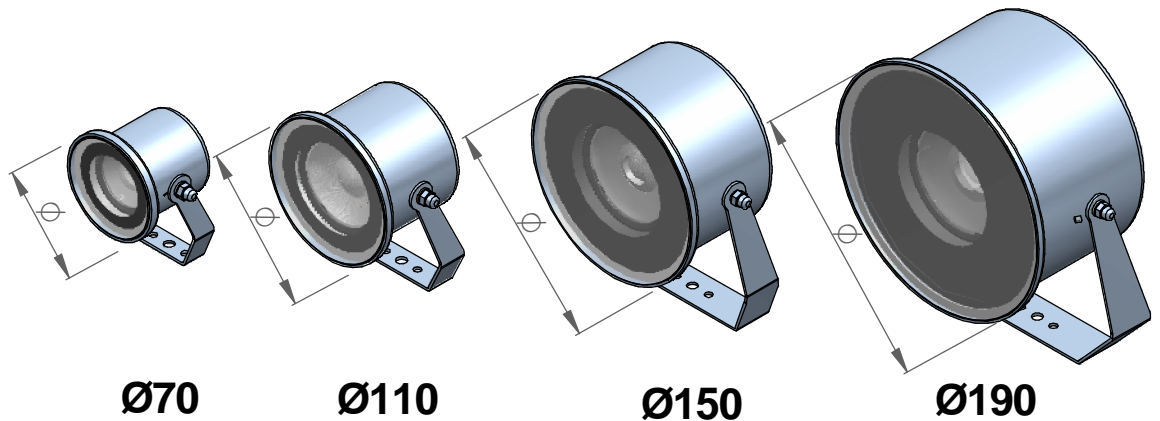
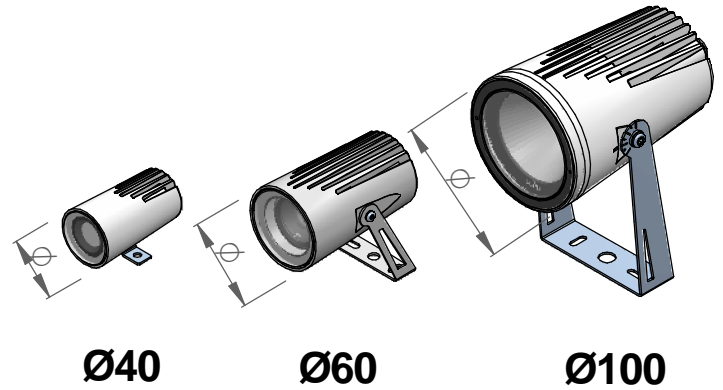

Installazione / Manutenzione

L'articolo dovrà essere installato da personale qualificato, **seguendo le normative d'installazione vigenti del paese di appartenenza**; In caso di malfunzionamento o necessità di manutenzione dell'articolo contattare il servizio clienti Linea Light tramite la seguente mail: support@linealight.com.

SONO SEVERAMENTE VIETATE LE OPERAZIONI DI INSTALLAZIONE E MANUTENZIONE DELL'ARTICOLO MENTRE QUEST ULTIMO È IN FUNZIONE: !!! ATTENZIONE !!! DURANTE IL FUNZIONAMENTO ALCUNE PARTI DELL'APPARECCHIO POSSONO RAGGIUNGERE TEMPERATURE ELEVATE.

Installation / Maintenance

The article must be installed by qualified personnel, **following the installation regulations in force in your country**; In the event of malfunction or need for maintenance of the article, contact Linea Light customer service via the following e-mail: support@linealight.com.

IT IS STRICTLY FORBIDDEN TO INSTALL AND MAINTAIN THE ARTICLE WHILE IT IS IN OPERATION; !!! WARNING !!! DURING OPERATION, CERTAIN PARTS OF THE APPLIANCE MAY REACH HIGH TEMPERATURES.

LINEA LIGHT declines any kind of responsibility if the instructions provided in the following instruction manual and in the main manual present in the article's packaging are not followed.

UTILIZZO CONFORME:

L'apparecchio è garantito esclusivamente se l'articolo in questione sia stato installato seguendo le istruzioni riportate in questo manuale di istruzioni e da quello generale presenti all'interno dell'imballaggio e scaricabili dal sito: www.linealight.com; **In caso di mancata osservazione delle precedenti avvertenze, l'azienda LINEA LIGHT declinerà ogni tipologia di responsabilità.**

Un utilizzo scorretto dell'articolo può influire nella durata utile della lampada e/o potrebbe causarne un guasto precoce. Evitare la pulizia dell'apparecchio utilizzando agenti chimici aggressivi, è sufficiente passare l'articolo con uno straccio inumidito con acqua. Per ulteriori avvertenze e/o spiegazioni di eventuali simboli si prega di visionare il foglio istruzioni generale.

CONSERVARE LE PRESENTI ISTRUZIONI PER FUTURI LAVORI DI INSTALLAZIONE/MANUTENZIONE.

COMPLIANT USE:

The luminaire is only guaranteed if the article in question has been installed in accordance with the instructions given in this instruction manual and the general manual found inside the packaging and downloadable from: www.linealight.com; **In the event of failure to comply with the above warnings, LINEA LIGHT declines all liability.**

Incorrect use of the article may affect the service life of the lamp and/or cause it to fail prematurely. Avoid cleaning the fixture using harsh chemicals, simply wipe the item with a cloth dampened with water. For further warnings and/or explanations of possible symbols please refer to the general instruction sheet.

KEEP THESE INSTRUCTIONS FOR FUTURE INSTALLATION/MAINTENANCE WORK.

(ITA) - I prodotti devono essere installati tassativamente con alimentazioni, cablaggi e accessori originali del Gruppo Linea Light, o eventualmente approvati dall'azienda. L'utilizzo di accessori non originali, o non approvati, determina il decadimento di ogni garanzia sul prodotto. **(ENG)** - All power supply, wiring and accessories used for product installation shall be original Linea Light Group parts or approved by the company. The warranty will become void if non original or non approved parts are used. **(FRA)** - Les produits doivent impérativement être installés avec des alimentations, des câblages et des accessoires Linea Light Group, ou qui ont été approuvés par l'entreprise. L'utilisation d'accessoires non d'origine, ou non approuvés, entraîne la déchéance de toute garantie sur le produit. **(ESP)** - Los productos se han de instalar obligatoriamente con alimentaciones, cableados y accesorios originales de Linea Light Group o, de otra forma, deben ser aprobados por la empresa misma. El uso de accesorios no originales, o no aprobados, anula todas las garantías del producto. **(GER)** Die Produkte müssen obligatorisch mit Originalstromversorgung, Originalkabeln und Originalzubehör der Linea Light Group oder mit Teilen, die von der Linea Light Group ausdrücklich empfohlen sind, installiert werden. Die Verwendung von nicht originale oder nicht vom Hersteller empfohlenem Zubehör führt zu einem sofortigen Verfall vom Garantieanspruch für das Produkt.

SERIES/SERIES: SHAKER | CLARK 316
BRAND: i-L^{ED}
MODELLI / MODELS

CODE	Dimensions (Ø x H mm)	Electrical Insulation Class	POWER R (WDC)	IP Degree	CLASS I / II		WEIGH T (Kg)	CRI	Energy class light source				No. light sourc e	Optic Control
					INPUT (V)	FREQUEN CY (Hz)			Temperature color LED (°K)					
					CLASS III				2200	2700	3000	4000		
					VOLTAGE (V)	CURRENT (mA)								
84241	43x74	II	2	66	220-240	50/60	0.2	80	F	D	D	D	1	standard
84242		II	2	66	220-240	50/60	0.2		F	D	D	D	1	
84243		II	2	66	220-240	50/60	0.2		F	D	D	D	1	
84244		II	2	66	220-240	50/60	0.2		F	D	D	D	1	
77611		II	2	66	220-240	50/60	0.2		F	D	D	D	1	
C00709	62x98	II	6.3	66	220-240	50/60	0.4		E	F	E	E	1	honeycomb
C00710		II	6.3	66	220-240	50/60	0.4		E	F	E	E	1	
C00711		III	6	66	9.5	630mA	0.4		E	F	E	E	1	standard
C00712	III	6	66	9.5	630mA	0.4	E		F	E	E	1	honeycomb	
84527	99x182	I	14	66	220-240	50/60	1.2		F	E	E	F	1	standard
84528		I	14	66	220-240	50/60	1.2		F	E	E	F	1	
84529		I	14	66	220-240	50/60	1.2		F	E	E	F	1	
84530		I	14	66	220-240	50/60	1.2		F	E	E	F	1	
77609		I	14	66	220-240	50/60	1.2		F	E	E	F	1	
76182		I	11.5	66	220-240	50/60	1.2		\	\	E	E	1	
76183		I	11.5	66	220-240	50/60	1.2		\	\	E	E	1	
76184		I	11.5	66	220-240	50/60	1.2		\	\	E	E	1	
76185		I	11.5	66	220-240	50/60	1.2		\	\	E	E	1	
77612		I	11.5	66	220-240	50/60	1.2		\	\	E	E	1	
C00140	73x111	II	3.2	67	220-240	50/60	0.6		\	F	E	E	1	standard
C00141		II	3.2	67	220-240	50/60	0.6		\	F	E	E	1	honeycomb
C00156		III	3.2	67	9	350	0.6		\	F	E	E	1	standard
C00157		III	3.2	67	9	350	0.6		\	F	E	E	1	honeycomb
C00142	112x148	II	11	67	220-240	50/60	1.05		\	E	E	E	1	standard
C00143		II	11	67	220-240	50/60	1.05		\	E	E	E	1	honeycomb
C00158		II	9	67	220-240	50/60	1.05		\	E	E	E	1	standard
C00159		II	9	67	220-240	50/60	1.05		\	E	E	E	1	honeycomb
C00154		147x199	II	15.5	67	220-240	50/60		1.75	\	E	E	E	1
C00160	II		15.5	67	220-240	50/60	1.75	\	E	E	E	1	standard	
C00155	II		15.5	67	220-240	50/60	1.75	\	E	E	E	1	honeycomb	
C00161	II		15.5	67	220-240	50/60	1.75	\	E	E	E	1	honeycomb	
C00773	190x244	II	25	67	220-240	50/60	2.3	\	E	E	E	1	standard	
C00775		II	25	67	220-240	50/60	2.3	\	E	E	E	1	standard	
C00774		II	25	67	220-240	50/60	2.3	\	E	E	E	1	honeycomb	
C00776		II	25	67	220-240	50/60	2.3	\	E	E	E	1	honeycomb	

Ta -20°C ÷ +50°C

**ACCESSORI NON INCLUSI
NOT INCLUDED ACCESSORIES**

***NON FISSARE LA SORGENTE LUMINOSA.
*DO NOT STARE AT LIGHT SOURCE.**
**A. ANTI-GLARE Ø70x50 mm
A. Ø70x50mm ANTI-GLARE**
cod.
C-U300018 (Shaker Ø62)

**B. ANTI-GLARE Ø106x75 mm
B. Ø106x75mm ANTI-GLARE**
cod.
99819 (Shaker Ø99)

**C. ANTI-GLARE Ø49x40 mm
C. Ø49x40mm ANTI-GLARE**
cod.
83246 (Shaker Ø43)

**D. PICCHETTO ACCIAIO L101mm
D. L101mm STEEL PEG**
cod.
98669 (only for Shaker Ø43)

**E. PICCHETTO DI FISSAGGIO
E. FIXING PEG**
cod.
89371 (Shaker Ø62 / Ø99)
98549 (Shaker Ø140 / Clark316)

**F. PICCHETTO ACCIAIO
F. STEEL PEG**
cod.
98624 - Ø10x160 (Shaker Ø43 / Ø62)
C-F500002 - Ø10x700 mm (Shaker Ø43 / Ø62)
C-F500003 - Ø10x1000mm (Shaker Ø43 / Ø62)
84890 - Ø17x160mm (CLark316)
98112 - Ø17x700mm (CLark316)
C-F500001 - Ø17x1000mm (CLark316)

SERIES: SHAKER | CLARK 316

BRAND: i-LèD

PRE-INSTALLAZIONE / PRE-INSTALLATION

PREDISPOSIZIONE DEI FORI D'INSTALLAZIONE SU PARETE / PAVIMENTO / SOFFITTO
DRILL THE ANCHORS' HOLES IN TO THE FLOOR / WALL / CEILING

Ø FORO TASSELLI
ANCHORS HOLE Ø

- Ø 5mm
- Ø 6mm

SHAKER Ø40



SHAKER Ø60



SHAKER Ø100



CLARK316
Ø70 / Ø110 / Ø150 / Ø190



INSTALLAZIONE / INSTALLATION

UTILIZZARE TASSELLI DA Ø5mm, INSTALLARE IL FARETTO NELLA POSIZIONE DESIDERATA (POSSIBILITA' DI ORIENTARE IL FARETTO TRAMITE BASCULAZIONE DELLO STESSO) / USE Ø5mm ANCHORS, INSTALL THE SPOTLIGHT IN THE DESIRED POSITION (IT'S POSSIBLE TO ADJUST THE BEAM ANGLE)

SHAKER

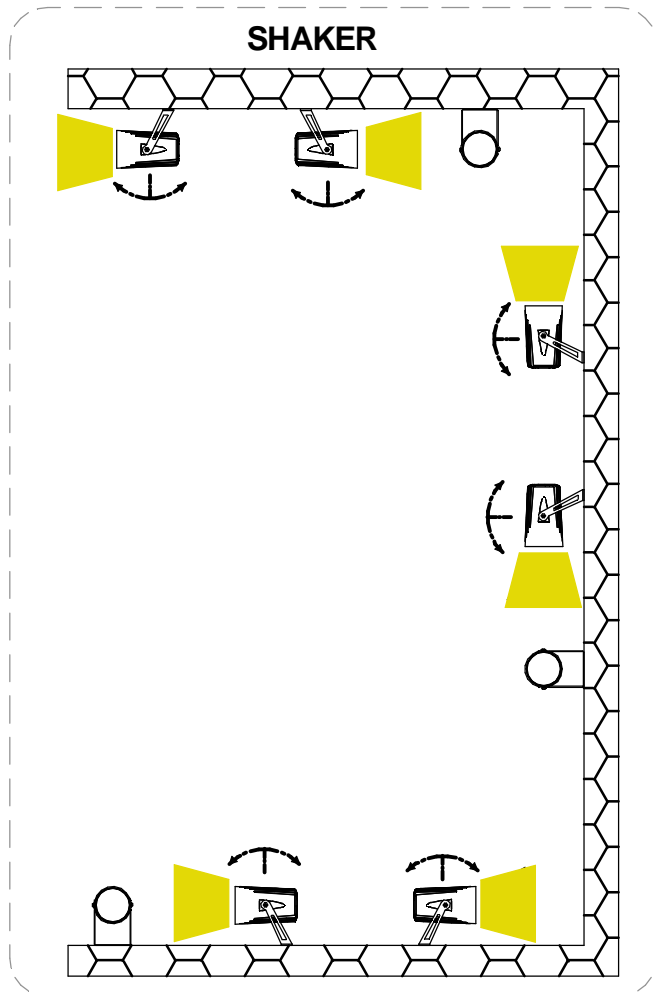

CLARK 316

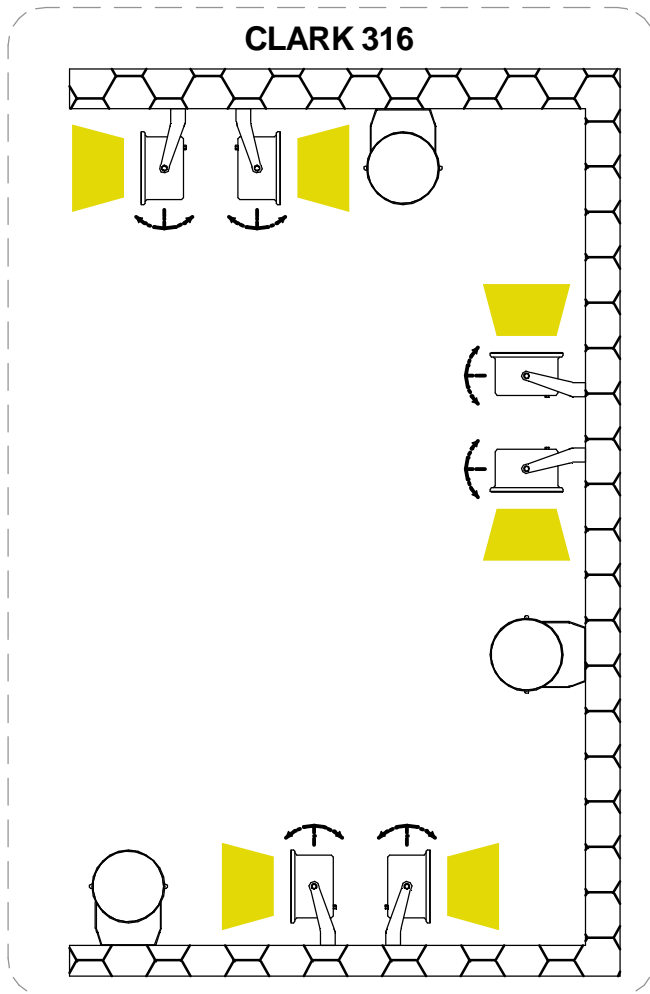

PER IL MONTAGGIO DEGLI ACCESSORI, FARE RIFERIMENTO AL FOGLIO D'ISTRUZIONE FGI00426
LOOK AT INSTALLATION INSTRUCTION FGI00426 TO INSTALLING THE ACCESSORIES

SHAKER

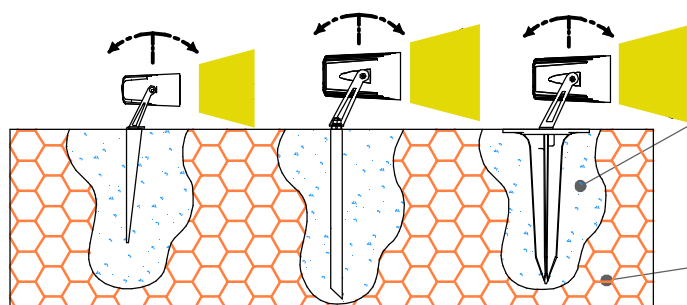

CLARK 316

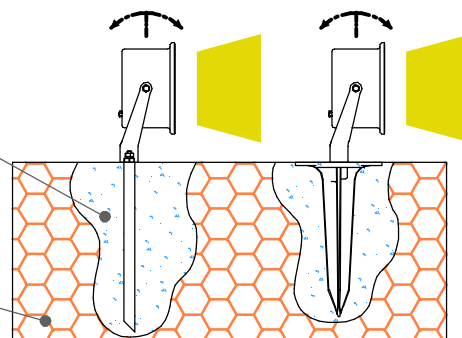

SERIES/SERIE: SHAKER | CLARK 316

BRAND: i-L^{ED}

INSTALLAZIONE SHAKER Ø40 e Ø62
SHAKER Ø40 and Ø62
INSTALLATION

INSERIRE I TASSELLI NEI FORI EFFETTUATI IN PRECEDENZA, RUOTARE IL FARO DI 90° IN MODO DA FAR PASSARE IL CACCIAVITE E AVVITARE VITE+RONDELLA

INSERT THE WALL PLUGS INTO THE HOLES PREVIOUSLY DRILLED, TURN THE SPOTLIGHT BY 90° SO THAT THE SCREWDRIVER CAN PASS THROUGH AND SCREW IN THE SCREW + WASHER

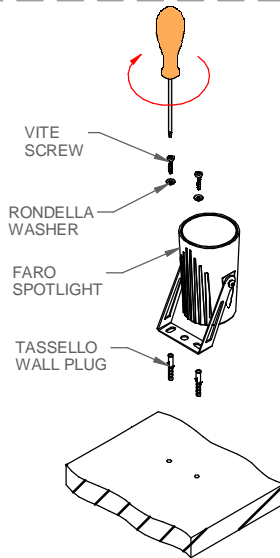

INSTALLAZIONE SHAKER Ø99/Ø140/TUTTI I CLARK316

SHAKER Ø99/Ø140/ALL CLARK316 INSTALLATION

RIMUOVERE LA STAFFA DAL FARO (A), INSERIRE I TASSELLI NEI FORI EFFETTUATI IN PRECEDENZA e AVVITARE LA STAFFA CON VITI+RONDELLE A QUESTI (B), RIMONTARE IL FARO SULLA STAFFA BLOCCATA (C)

REMOVE THE BRACKET FROM THE SPOTLIGHT (A), INSERT THE WALL PLUGS INTO THE HOLES PREVIOUSLY DRILLED AND SCREW THE BRACKET WITH SCREWS + WASHERS TO THESE (B), PLACE THE SPOTLIGHT ON THE LOCKED BRACKET (C)

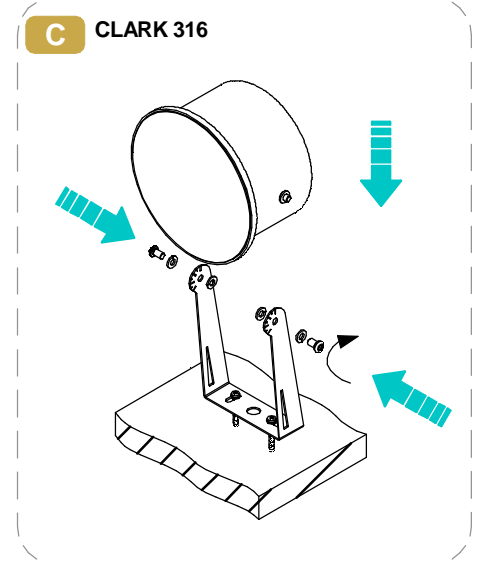
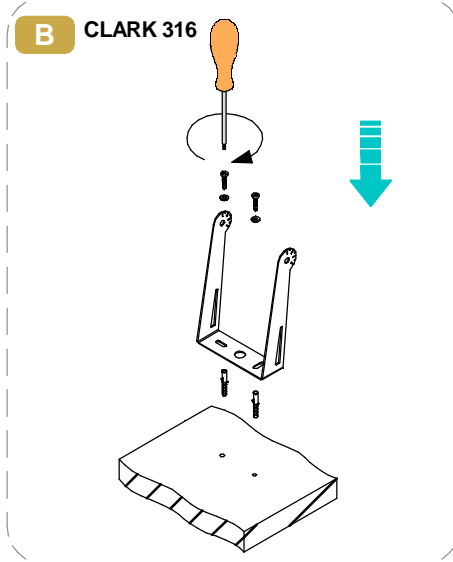
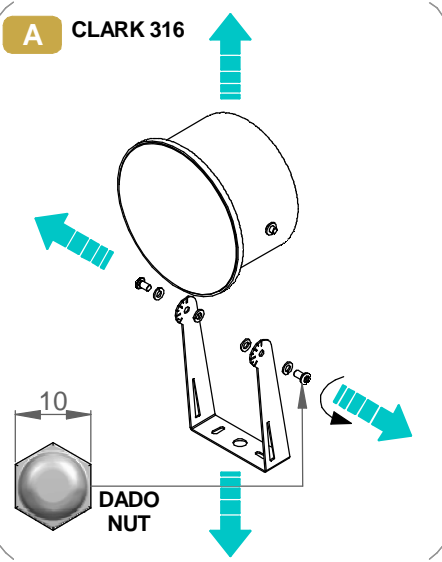
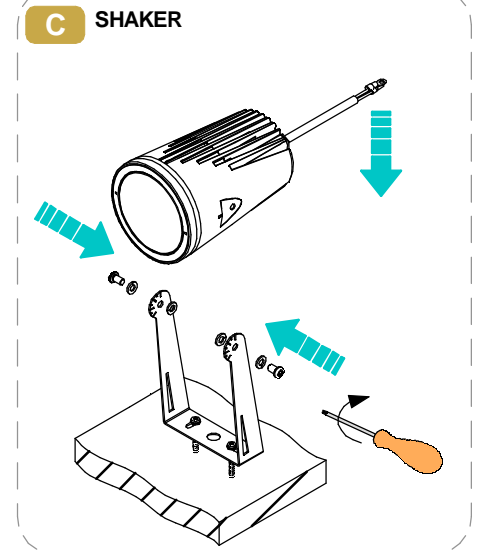
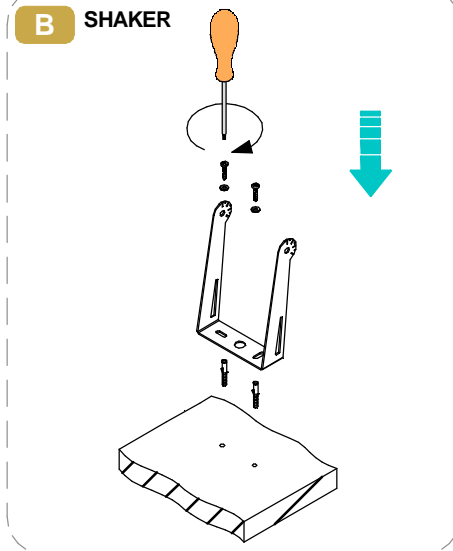
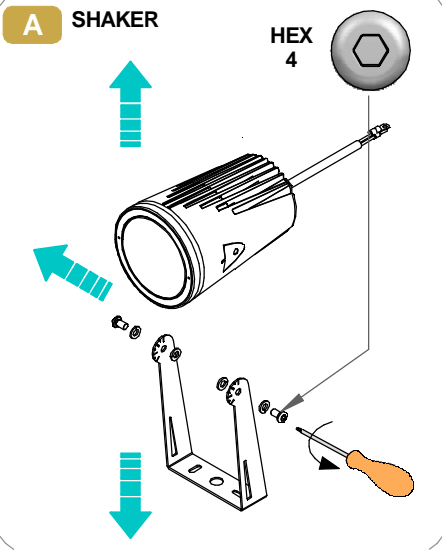

SERIES: SHAKER | CLARK 316

BRAND: i-LèD

MARRONE / BROWN = LINEA / LINE

AZZURRO / LIGHT BLUE = NEUTRO / NEUTRAL

GIALLO-VERDE / YELLOW-GREEN = TERRA / EARTH CPC | PE

CABLAGGIO / WIRING

1 TUTTE LE OPERAZIONI DI COLLEGAMENTO ALLA RETE ELETTRICA DEVONO ESSERE CONDOTTE IN MANCANZA DI TENSIONE
ALL THE WIRING OPERATION MUST BE PERFORMED WITH MCB IN OFF POSITION

2 SE IL PRODOTTO E' DEFINITO IN CLASSE 1, IL CONDUTTORE DI MESSA A TERRA DI PROTEZIONE DEVE ESSERE SEMPRE COLLEGATO
IF THE FITTING IS CLASS 1 RATED, THE CPC | EARTH | PE CONDUCTOR MUST BE CONNECTED

3 SE L'IMPIANTO E' STATO COMPLETATO ED E' IN SICUREZZA, PUO' ESSERE ALIMENTATO
WHEN THE CIRCUIT IS COMPLETED AND SAFE, MCB CAN BE SET IN ON POSITION

SE IL PRODOTTO E' DEFINITO IN CLASSE 3, IL CIRCUITO SECONDARIO A BASSA TENSIONE DEVE ESSERE COLLEGATO ALL'ALIMENTATORE PRIMA CHE QUESTO SIA SOTTO TENSIONE
IF THE FITTING IS CLASS 3 RATED, THE LOW VOLTAGE CIRCUIT MUST BE WIRED BEFORE THE POWER SUPPLY IS POWERED ON

SE IL CARICO VENISSE COLLEGATO AD ALIMENTATORE SOTTO TENSIONE, I PRODOTTI POTREBBERO DANNEGGIARSI, SUBENDO UN DANNO DA SOVRATENSIONE
IF THE LOAD IS WIRED TO AN ALREADY ON POWER SUPPLY, THE FITTINGS COULD BE DAMAGED BY VOLTAGE SURGE

CABLAGGIO IN PARALLELO | PARALLEL WIRING TENSIONE DI RETE | MAINS VOLTAGE

AC

N° MAX SHAKER

MAX N° SHAKER x MCB

CODE	B10	B16	B20	C10	C16	C20
84527 84528 84529 84530 77609	51	83	103	85	138	172
76182 76183 76184 76185 77612	90	146	182	106	170	212
84532 84533 84534 84535 77610	27	44	55	46	74	92

CABLAGGIO IN PARALLELO | PARALLEL WIRING TENSIONE DI RETE | MAINS VOLTAGE

AC

MAX N° SHAKER x MCB

CODE	A10	A16	A20	B10	B16	B20	C10	C16	C20
84241 84242 84243 84244 77611	\	\	\	18	30	37	31	50	62
C00709 C00710	\	\	\	40	64	80	64	102	128
C00140 C00141	22	36	60	36	58	72	60	96	120
C00142 C00143	\	\	\	\	15	\	\	24	\
C00158 C00159	29	46	58	46	74	93	74	119	149
C00154 C00155	\	\	\	\	15	\	\	24	\
C00160 C00161	\	\	\	\	30	\	\	50	\
C00773 C00774	\	\	\	\	36	\	\	60	\
C00775 C00776	\	\	\	\	40	\	\	65	\

SERIE/SERIES: SHAKER | CLARK 316

BRAND: i-LED

CABLAGGIO IN SERIE | CORRENTE COSTANTE
SERIES WIRING | CONSTANT CURRENT

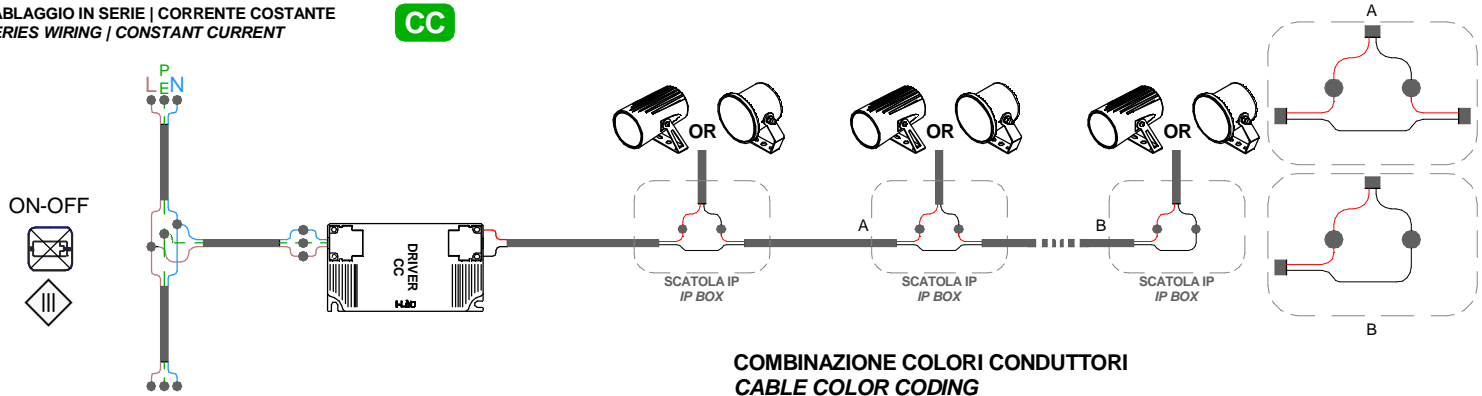

**COMBINAZIONE COLORI CONDUTTORI
CABLE COLOR CODING**

- NERO/BLACK = NEGATIVO - / NEGATIVE -
- ROSSO/RED = POSITIVO + / POSITIVE +

DRIVER SHAKER 630mA

CODE	POWER	TYPE	N° MAX PRODOTTI DEVICES
C-E200008	6-12,5 W	ON/OFF	1-2
99186	12-24 W	ON/OFF	2-4
C-E200002	9-21,5 W	DALI / PUSH	2-4

DRIVER CLARK 316 350mA

CODE	POWER	TYPE	N° MAX PRODOTTI DEVICES
89421	3,5-6,5 WDC	ON/OFF	1-2
C-E200006	6-12,5 WDC	ON/OFF	2-4
C-E200004	5-12,5 WDC	DALI / PUSH	2-4

CABLE SECTION [mm ²]	MAX CABLE LENGTH [m]*
0,5	20
1	40
1,5	60