

- 9637
- 9637M
- 9638
- 9638M
- 9639
- 9639M
- 9640
- 9640M

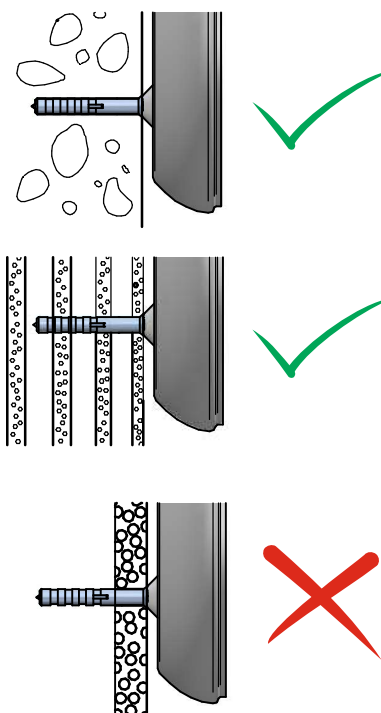

**ATTENZIONE**  
PER L'INSTALLAZIONE E UTILIZZO DELL'APPARECCHIO  
ATTENERSI ALLE ISTRUZIONI DI SEGUITO.  
QUALSIASI VARIANTE DEVE ESSERE CONCORDATA  
CON L'AZIENDA PER NON PERDERE LA GARANZIA

1

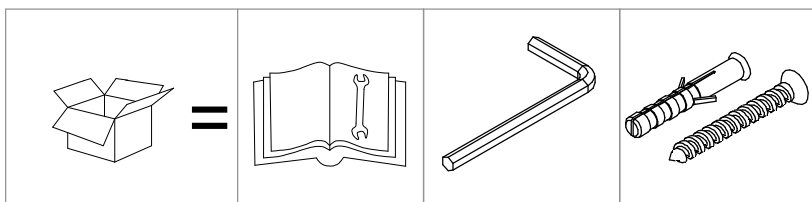
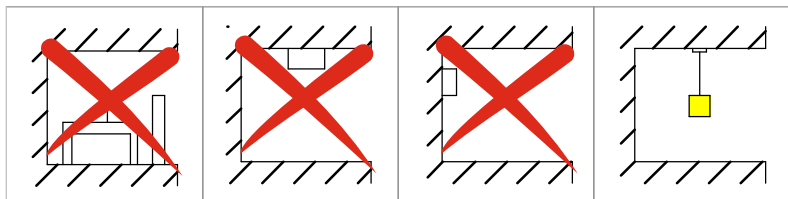
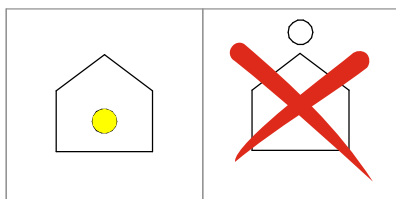
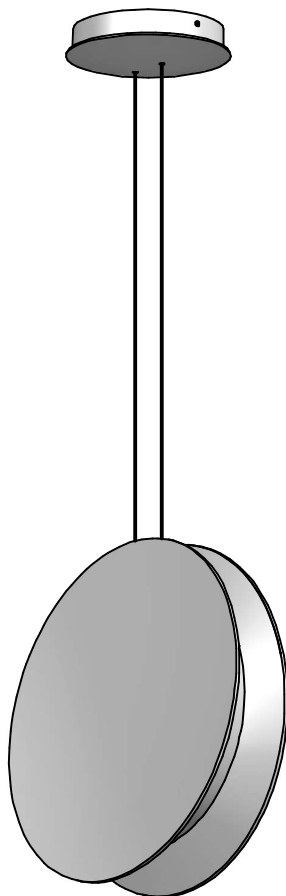
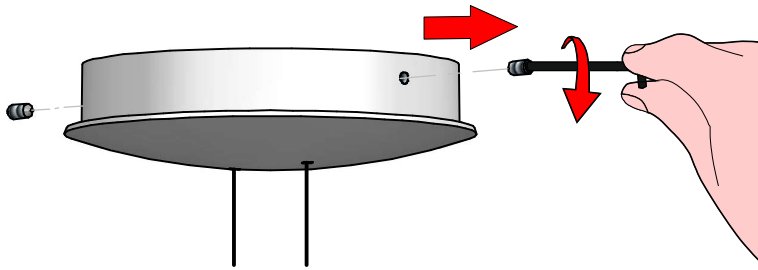

2

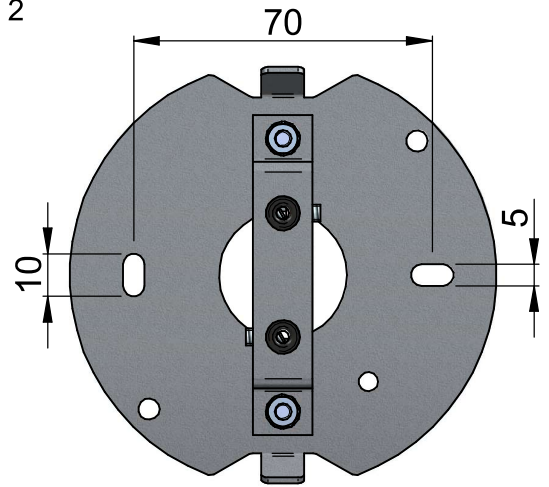

3

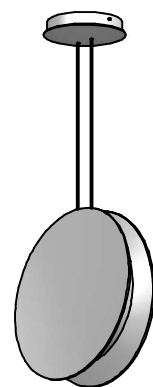
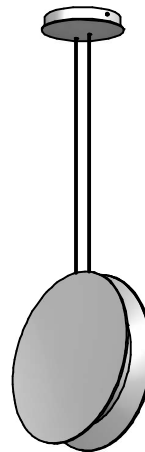
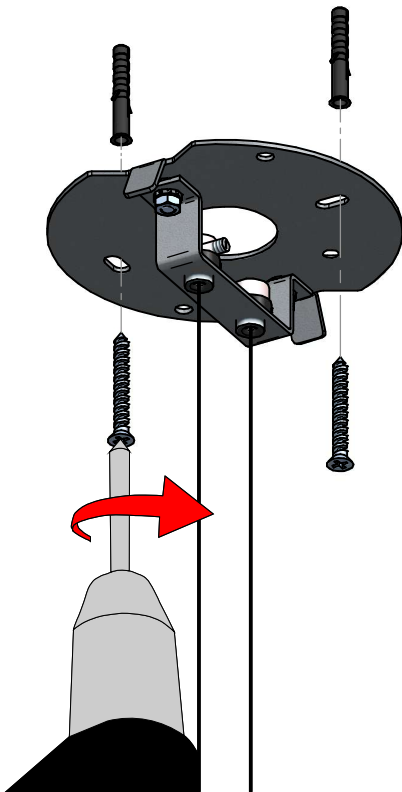

4

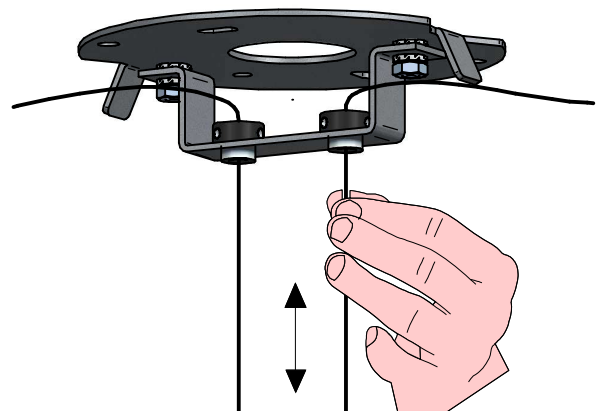
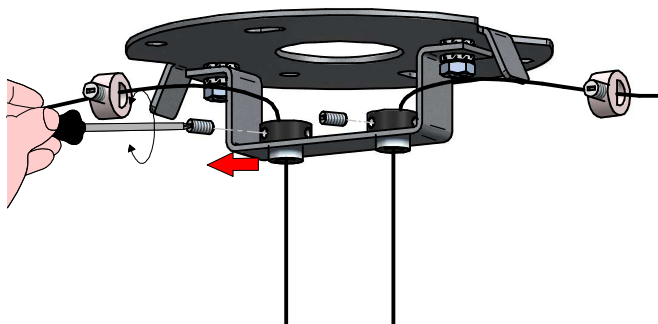

5

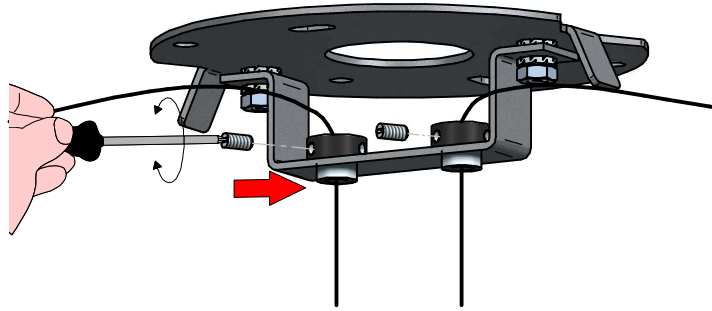

6

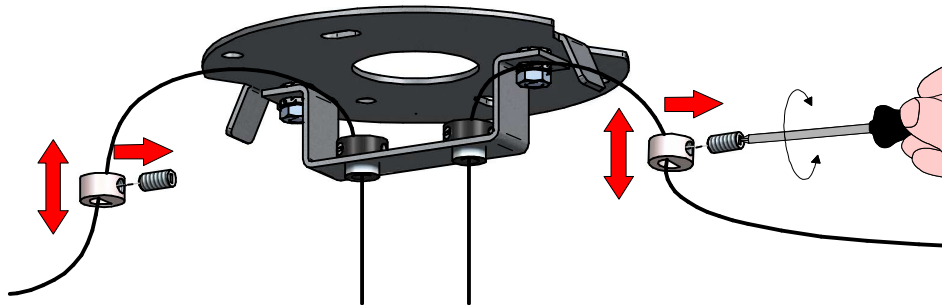

7

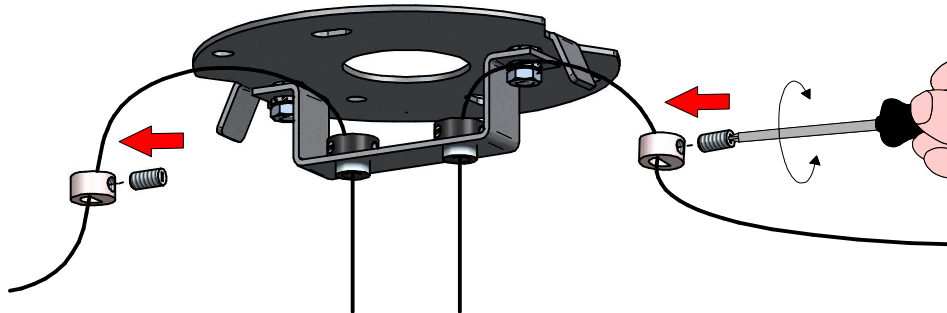

8

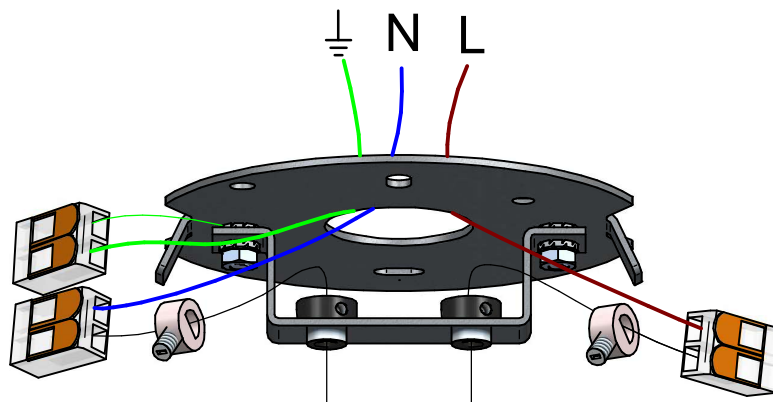

9

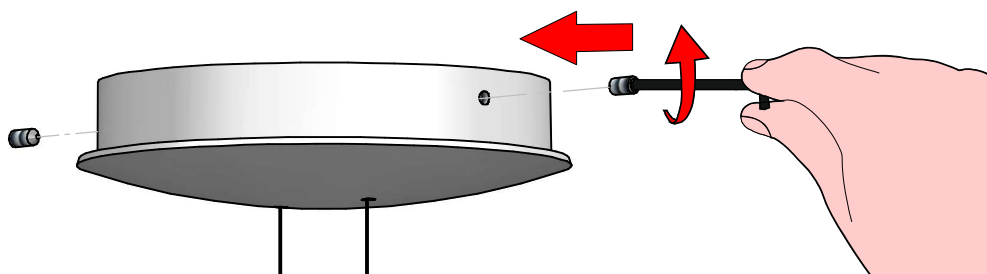

**ISTRUZIONI PER IL LAVAGGIO DELL'APPARECCHIO D'ILLUMINAZIONE**  
**LUMINAIRE CARE INSTRUCTIONS**  
**ISTRUCCIONES PARA LIMPIAR LA LUMINARA**  
**INSTRUCTIONS POUR LE LAVAGE DE L'APPAREIL D'ECLAIRAGE**  
**ANLEITUNG ZUR REINIGUNG DES BELEUCHTUNGSGERATS**

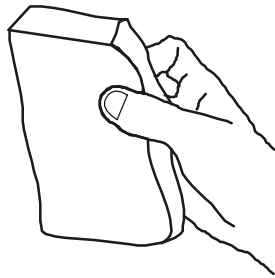
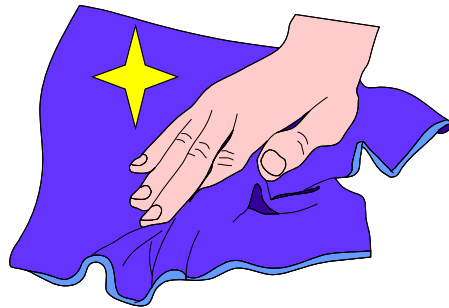

**IT - ATTENZIONE!!!**

Lavare la superficie della lampada con panno umido, utilizzando solo acqua e sapone neutro.

**EN - WARNING!!!**

Wipe clean with a cloth dampened in water with neutral detergent.

**ES - ATENCION!!!**

Limpie la superficie de la lámpara con un pano humedecido con agua y jabon neutro.

**FR - ATTENTION!!!**

Laver la surface de la lampe a l'aide d'un chiffon humide et en utilisant seulement de l'eau et du savon neutre.

**DE - ACHTUNG!!!**

Die Lampenoberfläche mit einem feuchten lappen reinigen. De lappen mit wasser und neutralseife befeuchten.

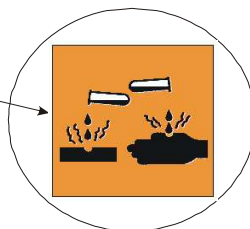
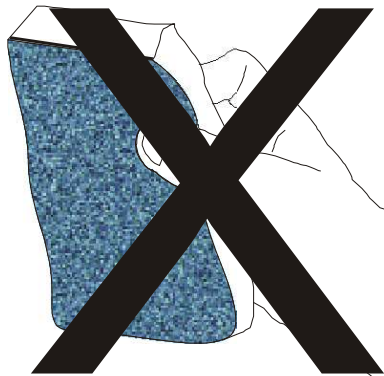

**IT - ATTENZIONE!!!**

Non utilizzare panni abrasivi e/o solventi.

**EN - WARNING!!!**

Avoiding the use of chemical solvents and/or abrasive cloths.

**ES - ATENCION!!!**

No utilizar panos abrasivos y solventes.

**FR - ATTENTION!!!**

Ne pas utiliser de chiffons abrasifs ou de dissolvants.

**DE - ACHTUNG!!!**

Abschleifende tuche und/oder losungmittel nicht benutzen.