

ART. THIN66 - THIN66 RGBW

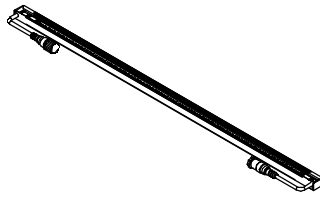
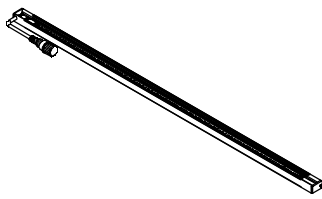
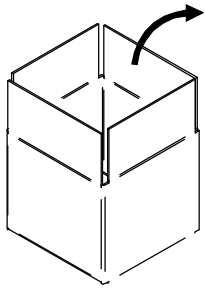

linea light Product Code: Casella personalizzabile Customizable box

This luminaire contains built-in LED lamps.

A+ A A C D F

LED

The lamps cannot be changed in the luminaire.

874/2012

Etichetta energetica scaricabile dal sito www.linealight.com
Energy label downloaded from the website www.linealight.com

1.

Clip di fissaggio incluse
Fixing clips included

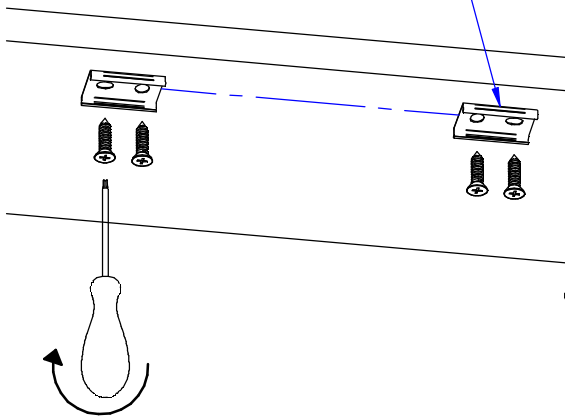

2.

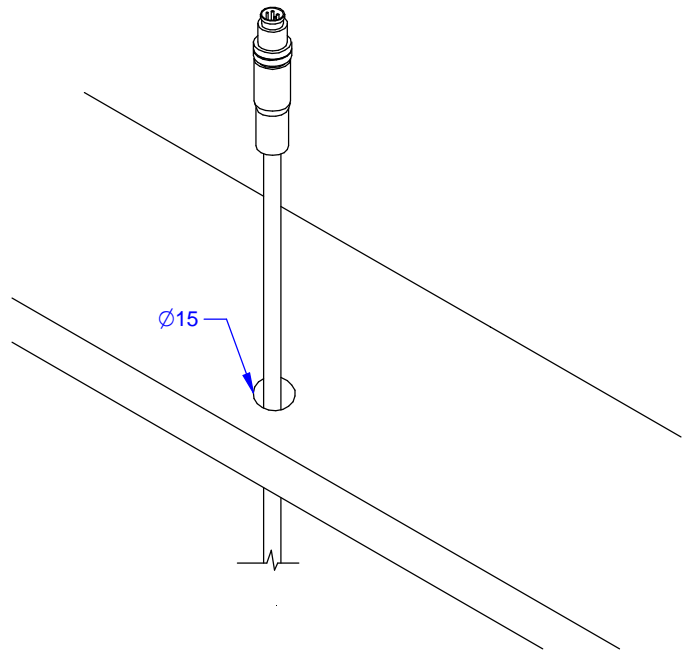

3.

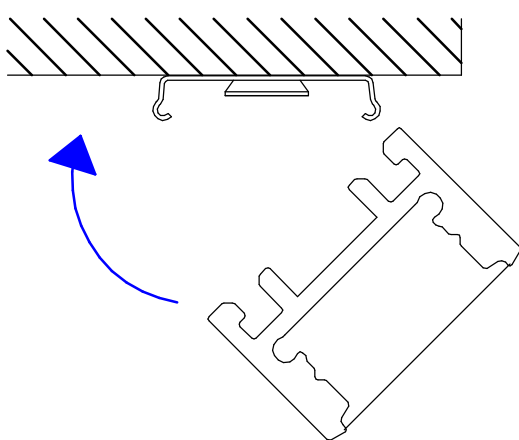

4.

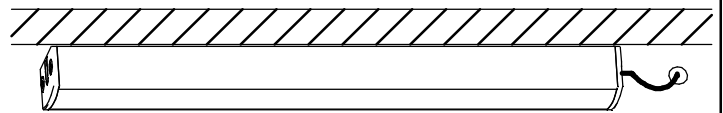

Serie : Thin66 | 24Vdc

ART. 83885 83889 83886 83890 83887 83891 83888 83892

ARTICOLO SENZA ALIMENTATORE A BORDO / ARTICLE WITHOUT DRIVER ON BOARD

ITA	ENG	FRA	DEU	ESP
Procedura di cablaggio 1 Spegnere l'interruttore generale. OFF 2 Collegare le Thin66 all'alimentatore. 3 Collegare l'alimentatore alla linea d'alimentazione principale. 4 Accendere l'interruttore generale. ON N.B. Tutte le operazioni di manutenzione ed installazione vanno eseguite con l'interruttore generale spento. OFF Le Thin66 vanno alimentate a tensione costante 24Vdc. IL PRODOTTO RISULTA GARANTITO SOLO CON ALIMENTATORI DISTRIBUITI DA H.LÈD.	Wiring procedure 1 Switch off the main switch. OFF 2 Connect the Thin66 to the power supply unit. 3 Connect the power supply unit to the main line power. ON 4 Switch on the main switch. ON N.B. All maintenance and installation operations must be carried out with the main switch turned off. OFF The Thin66 must be powered at 24Vdc in constant voltage. THE PRODUCT IS GUARANTEED ONLY WITH POWER SUPPLIERS DISTRIBUTED BY H.LÈD.	Procédure de câblage 1 Éteignez l'interrupteur principal. OFF 2 Connectez le Thin66 à l'unité d'alimentation. 3 Connectez le bloc d'alimentation à l'alimentation principale. 4 Allumer l'interrupteur principal. ON N.B. Toutes les opérations de maintenance et d'installation doivent être effectuées avec l'interrupteur principal sur OFF. OFF Le Thin66 doit être alimenté à 24 Vcc en tension constante. LE PRODUIT EST GARANTI UNIQUEMENT AVEC LES FOURNISSEURS DE DISTRIBUTION H.LÈD.	Anleitung zur Verkabelung 1 Hauptschalter ausschalten. OFF 2 Schließen Sie den Thin66 an das Netzteil an. 3 Schließen Sie das Netzteil an die Hauptstromversorgung an. 4 Hauptschalter einschalten. ON N.B. Alle Wartungs- und Installationsarbeiten müssen bei ausgeschaltetem Hauptschalter ausgeführt werden. OFF Der Thin66 muss mit einer konstanten Spannung von 24 VDC betrieben werden. DAS PRODUKT WIRD NUR MIT VON H.LÈD VERTEILTEN NETZTEILEN GARANTIERT.	Procedimiento de cableado 1 Apague el interruptor principal. OFF 2 Conecte el Thin66 a la fuente de alimentación. 3 Conecte la fuente de alimentación a la línea de alimentación principal. 4 Encienda el interruptor principal. ON N.B. Todas las operaciones de mantenimiento e instalación deben realizarse con el interruptor principal apagado. OFF El Thin66 debe ser alimentado a 24Vdc en voltaje constante. EL PRODUCTO ESTÁ GARANTIZADO SOLO CON LOS FUENTES DE ALIMENTACIÓN DISTRIBUIDOS POR H.LÈD.

(ITA) - I prodotti devono essere installati tassativamente con alimentazioni, cablaggi e accessori originali del Gruppo Linea Light, o eventualmente approvati dall'azienda. L'utilizzo di accessori non originali, o non approvati, determina il decadimento di ogni garanzia sul prodotto.
 (ENG) - All power supply, wiring and accessories used for product installation shall be original Linea Light Group parts or approved by the company. The warranty will become void if non original or non approved parts are used.
 (FRA) - Les produits doivent impérativement être installés avec des alimentations, des câblages et des accessoires Linea Light Group, ou qui ont été approuvés par l'entreprise. L'utilisation d'accessoires non d'origine, ou non approuvés, entraîne la déchéance de toute garantie sur le produit.
 (ESP) - Los productos se han de instalar obligatoriamente con alimentaciones, cableados y accesorios originales de Linea Light Group o, de otra forma, deben ser aprobados por la empresa misma. El uso de accesorios no originales, o no aprobados, anula todas las garantías del producto.
 (GER) Die Produkte müssen obligatorisch mit Originalstromversorgung, Originalkabeln und Originalzubehör der Linea Light Group oder mit Teilen, die von der Linea Light Group ausdrücklich empfohlen sind, installiert werden. Die Verwendung von nicht originalen oder nicht vom Hersteller empfohlenem Zubehör führt zu einem sofortigen Verfall vom Garantieanspruch für das Produkt.

(ITA) - Collegare i fili BLU e NERO del 99216 o 89190 al NEGATIVO dell'alimentatore da 24Vdc. Collegare i fili MARRONE e BIANCO del 99216 o 89190 al POSITIVO dell'alimentatore da 24Vdc.

- CAVO BLU / blue cable = - NEGATIVE
- CAVO NERO / black cable = - NEGATIVE
- CAVO MARRONE / brown cable = + POSITIVE
- CAVO BIANCO / white cable = + POSITIVE

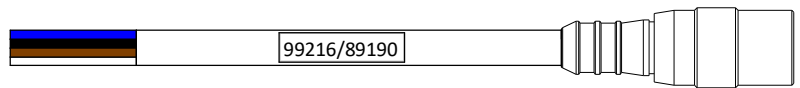

(ENG) - Connect BLU and BLACK wires of 99216 or 89190 to NEGATIVE of the power supply. Connect BROWN and WHITE wires of 99216 or 89190 to POSITIVE of the 24Vdc power supply.

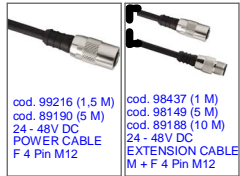

Lunghezza totale linea cavi a massimo carico 96W / Total cables length at maximum load 96W:

SEZIONE/ section	1mm ²	1,5mm ²	2,5mm ²
LUNGHEZZA/ length	15m	25m	40m

Evidenziato in giallo la sezione dei cavi I-Lèd: cavi iniziali (99216, 89190); estensioni (98437, 98149, 89188).

I-Lèd cables section highlighted in yellow: power cables (99216, 89190); extension (98437, 98149, 89188).

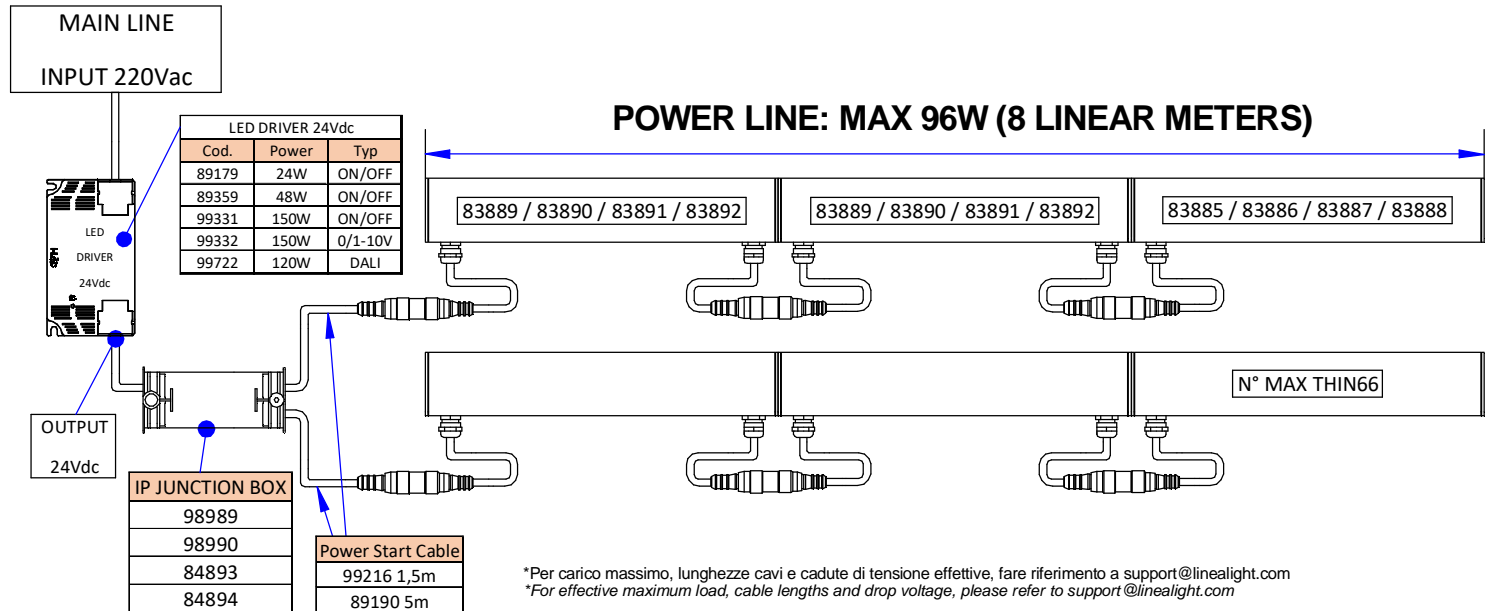

*Per carico massimo, lunghezze cavi e cadute di tensione effettive, fare riferimento a support@linealight.com
 *For effective maximum load, cable lengths and drop voltage, please refer to support@linealight.com

MOD.	COD.	LENGTH mm	MAX N° THIN66 COLLEGABLE ON A POWER LINE*	MAX N° THIN66 COLLEGABLE ON 89179	MAX N° THIN66 COLLEGABLE ON 89359	MAX N° THIN66 COLLEGABLE ON 99331	MAX N° THIN66 COLLEGABLE ON 99332	MAX N° THIN66 COLLEGABLE ON 99722
THIN66	83885	539	1	4	8	25	25	20
	83889	539	20	4	8	25	25	20
	83886	1039	1	2	4	12	12	10
	83890	1039	10	2	4	12	12	10
	83887	1539	1	1	2	7	7	6
	83891	1539	6	1	2	7	7	6
	83888	2039	1	1	2	6	6	6
	83892	2039	5	1	2	6	6	5

Serie : THIN66 DMX RGBW | 24Vdc

ART. 84060 84061 84062 84063 84064 84065 84066 84067

ARTICOLO SENZA ALIMENTATORE A BORDO / ARTICLE WITHOUT DRIVER ON BOARD

ITA	ENG	FRA	DEU	ESP
<p>Procedura di cablaggio</p> <p>1 Spegner l'interruttore generale. OFF</p> <p>2 Collegare il Thin66 all'alimentatore.</p> <p>3 Collegare l'alimentatore alla linea d'alimentazione principale.</p> <p>4 Accendere l'interruttore generale. ON</p> <p>N.B Tutte le operazioni di manutenzione ed installazione vanno eseguite con l'interruttore generale spento. OFF</p> <p>La Thin66 vanno alimentate a tensione costante 24Vdc</p> <p>IL PRODOTTO RISULTA GARANTITO SOLO CON ALIMENTATORI DISTRIBUITI DA I-LèD.</p>	<p>Wiring procedure</p> <p>1 Switch off the main switch. OFF</p> <p>2 Connect the Thin66 to the power supply unit.</p> <p>3 Connect the power supply unit to the main line power.</p> <p>4 Switch on the main switch. ON</p> <p>N.B All maintenance and installation operations must be carried out with the main switch turned off. OFF</p> <p>The Thin66 must be powered at 24Vdc in constant voltage.</p> <p>THE PRODUCT IS GUARANTEED ONLY WITH POWER SUPPLIERS DISTRIBUTED BY I-LèD.</p>	<p>Procédure de câblage</p> <p>1 Éteignez l'interrupteur principal. OFF</p> <p>2 Connectez le Thin66 à l'unité d'alimentation.</p> <p>3 Connectez le bloc d'alimentation à l'alimentation principale.</p> <p>4 Allumer l'interrupteur principal. ON</p> <p>N.B Toutes les opérations de maintenance et d'installation doivent être effectuées avec l'interrupteur principal sur OFF. OFF</p> <p>Le Thin66 doit être alimenté à 24 Vcc en tension constante.</p> <p>LE PRODUIT EST GARANTI UNIQUEMENT AVEC LES FOURNISSEURS DE DISTRIBUTION I-LèD.</p>	<p>Anleitung zur Verkabelung</p> <p>1 Hauptschalter ausschalten. OFF</p> <p>2 Schließen Sie den Thin66 an das Netzteil an.</p> <p>3 Schließen Sie das Netzteil an die Hauptstromversorgung an.</p> <p>4 Hauptschalter einschalten. ON</p> <p>N.B Alle Wartungs- und Installationsarbeiten müssen bei ausgeschaltetem Hauptschalter ausgeführt werden. OFF</p> <p>Der Thin66 muss mit einer konstanten Spannung von 24 VDC betrieben werden.</p> <p>DAS PRODUKT WIRD NUR MIT VON I-LèD VERTEILTEN NETZTEILEN GARANTIERT.</p>	<p>Procedimiento de cableado</p> <p>1 Apague el interruptor principal. OFF</p> <p>2 Conecte el Thin66 a la fuente de alimentación.</p> <p>3 Conecte la fuente de alimentación a la línea de alimentación principal.</p> <p>4 Encienda el interruptor principal. ON</p> <p>N.B Todas las operaciones de mantenimiento e instalación deben realizarse con el interruptor principal apagado. OFF</p> <p>El Thin66 debe ser alimentado a 24Vdc en voltaje constante.</p> <p>EL PRODUCTO ESTÁ GARANTIZADO SOLO CON LOS FUENTES DE ALIMENTACIÓN DISTRIBUIDOS POR I-LèD.</p>

(ITA) - I prodotti devono essere installati tassativamente con alimentazioni, cablaggi e accessori originali del Gruppo Linea Light, o eventualmente approvati dall'azienda. L'utilizzo di accessori non originali, o non approvati, determina il decadimento di ogni garanzia sul prodotto.

(ENG) - All power supply, wiring and accessories used for product installation shall be original Linea Light Group parts or approved by the company. The warranty will become void if non original or non approved parts are used.

(FRA) - Les produits doivent impérativement être installés avec des alimentations, des câblages et des accessoires Linea Light Group, ou qui ont été approuvés par l'entreprise. L'utilisation d'accessoires non d'origine, ou non approuvés, entraîne la déchéance de toute garantie sur le produit.

(ESP) - Los productos se han de instalar obligatoriamente con alimentaciones, cableados y accesorios originales de Linea Light Group o, de otra forma, deben ser aprobados por la empresa misma. El uso de accesorios no originales, o no aprobados, anula todas las garantías del producto.

(GER) Die Produkte müssen obligatorisch mit Originalstromversorgung, Originalkabeln und Originalzubehör der Linea Light Group oder mit Teilen, die von der Linea Light Group ausdrücklich empfohlen sind, installiert werden. Die Verwendung von nicht originalen oder nicht vom Hersteller empfohlenem Zubehör führt zu einem sofortigen Verfall vom Garantieanspruch für das Produkt.



Lunghezza totale linea cavi a massimo carico 48W / Total cables length at maximum load 48W:

SEZIONE/ section	0,5mm ²	1mm ²	1,5mm ²	2,5mm ²
LUNGHEZZA/ length	15m	30m	45m	75m

Evidenziato in giallo la sezione dei cavi I-Lèd: cavo iniziale (89362); estensione (89361).

I-Lèd cables section highlighted in yellow: power cable (89362); extension (89361).

(ITA) - Collegare il filo MARRONE del 89362 al NEGATIVO del canale ROSSO.
Collegare il filo BIANCO del 89362 al NEGATIVO del canale VERDE.
Collegare il filo BLU del 89362 al NEGATIVO del canale BLU.
Collegare il filo BLACK del 89362 al POSITIVO COMUNE 24Vdc.
Collegare il filo GRIGIO del 89362 al NEGATIVO del canale BIANCO.

- CAVO MARRONE / brown cable = (-) ROSSO / red
- CAVO BIANCO / white cable = (-) VERDE / green
- CAVO BLU / blue cable = (-) BLU / blue
- CAVO NERO / black cable = (+) COMUNE / common
- CAVO GRIGIO/ grey cable = (-) BIANCO / white

(ENG) - Connect BROWN wire of 89362 to NEGATIVE of RED channel.
Connect WHITE wire of 89362 to NEGATIVE of GREEN channel.
Connect BLU wire of 89362 to NEGATIVE of BLU channel.
Connect BLACK wire of 89362 to COMMUN POSITIVE 24Vdc.
Connect GREY wire of 89362 to NEGATIVE of WHITE channel.

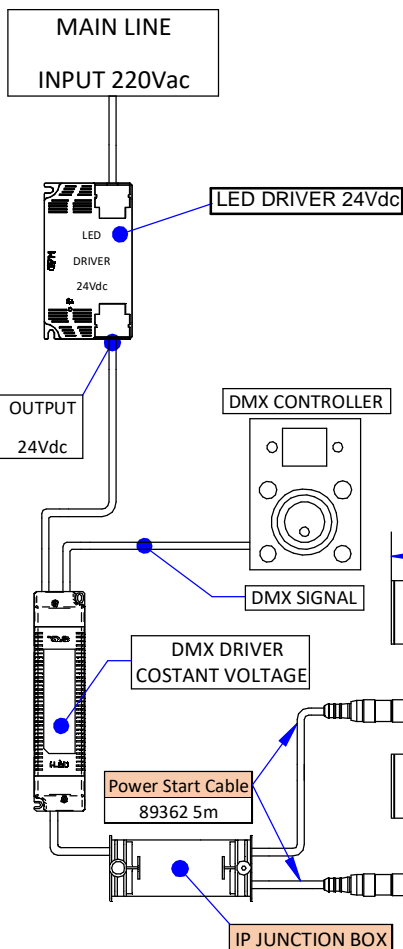
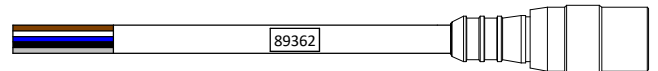

MOD.	COD.	LENGTH mm	MAX N° THIN66 COLLEGABLE ON A POWER LINE*	MAX N° THIN66 COLLEGABLE ON A 288W DMX DRIVER CV
THIN66	84060	539	1	25
	84064	539	4	25
	84061	1039	1	12
	84065	1039	2	12
	84062	1539	1	7
	84066	1539	1	7
	84063	2039	1	5
	84067	2039	1	5

*Per carico massimo, lunghezze cavi e cadute di tensione effettive, fare riferimento a support@linealight.com
*For effective maximum load, cable lengths and drop voltage, please refer to support@linealight.com

POWER LINE: MAX 48W (2,5 LINEAR METERS)

