

SERIE / SERIES: MINI-ALBATROS

BRAND: i-L^{ED}

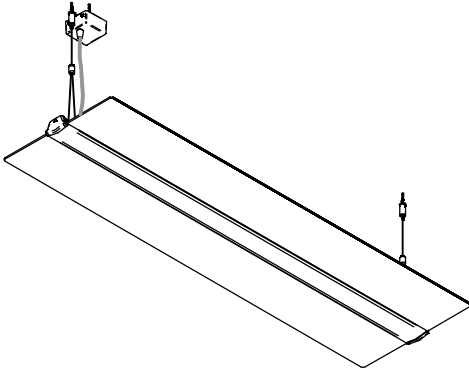
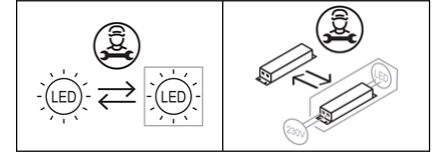
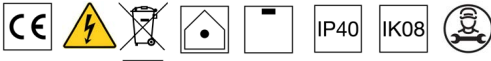

A

**MINI_ALBATROS
COMPLETE**

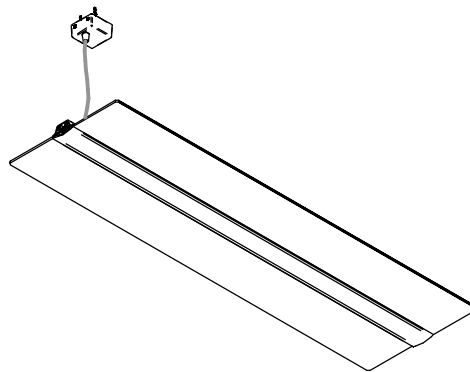

B

**MINI_ALBATROS_M
MASTER**

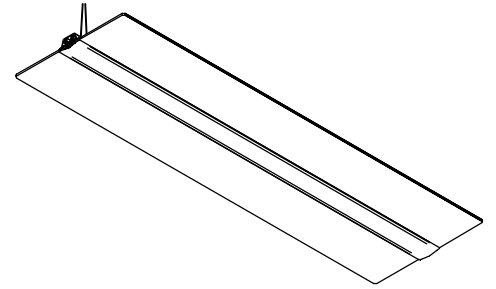

C

**MINI_ALBATROS_S
SLAVE**

CODICI / CODES

CODE	TYPE	DIMMING	Dimensions (LxWxH / ø x H mm)	Electrical Insulation Class	POWER (W)	VOLTAGE (V)	FREQ. [Hz]	WEIGHT (Kg)	IP	IK	CRI	Energy class light source		No. light source	Conn. Type											
												Temperature color LED (°K)														
												3500	4000													
82834	COMPLETE	ON-OFF	1125 x 36 x 338	2	44	220-240	50/60	4	40	8	90	E	E	8	Y											
82749		DALI				220-240	50/60									4,8	10	Y								
82836		ON-OFF	1414 x 36 x 338		220-240	50/60	4	8											Y							
82751		DALI			220-240	50/60										4,8	10	Y								
82838	MASTER	ON-OFF	1125 x 36 x 338		44	220-240	50/60	4						40	8				90	E	E	8	Y			
82823		DALI				220-240	50/60									4,8	10	Y								
82840		ON-OFF	1414 x 36 x 338		220-240	50/60	4	8																Y		
82825		DALI			220-240	50/60										4,8	10	Y								
82842	SLAVE	ON-OFF	1125 x 36 x 338		44	220-240	50/60	4														40	8	90	E	E
82827		DALI				220-240	50/60									4,8	10	Y								
82844		ON-OFF	1414 x 36 x 338		220-240	50/60	4	8																		
82829		DALI			220-240	50/60										4,8	10	Y								

Ta -20°C ÷ 50°C

DIMENSIONI / DIMENSIONS

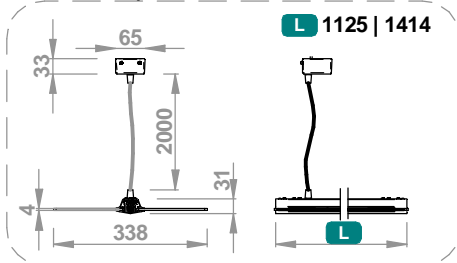

ACCESSORI INCLUSI / INCLUDED ACCESSORIES

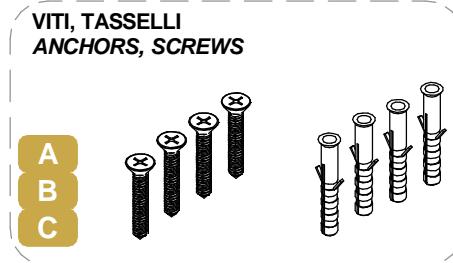

CAVO DI SOSPENSIONE
SUSPENSION CABLE

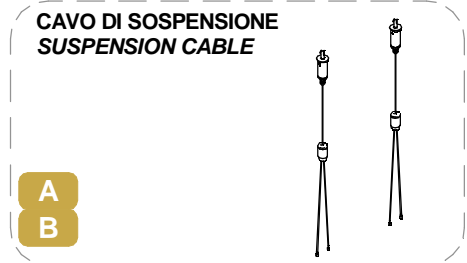

TAPPI DI CHIUSURA
ENDCAPS



GIUNTO CAVO DI SOSPENSIONE
SUSPENSION CABLE JOINT

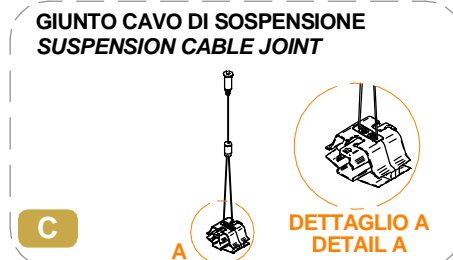

ACCESSORI NON INCLUSI / NOT INCLUDED
ACCESSORIES
FISSAGGIO PER CONTROSOFFITTO
FALSE CEILING FIXING

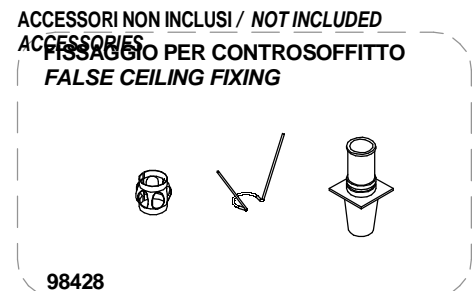

SERIE / SERIES: MINI-ALBATROS

BRAND: i-LED

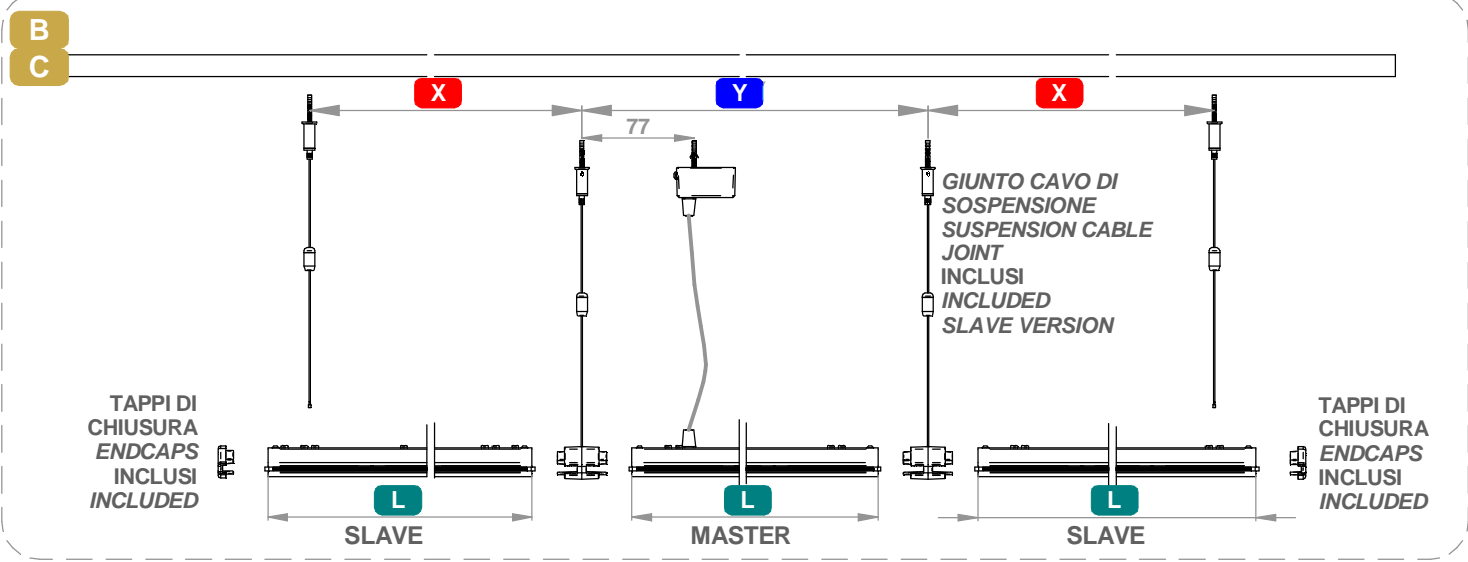
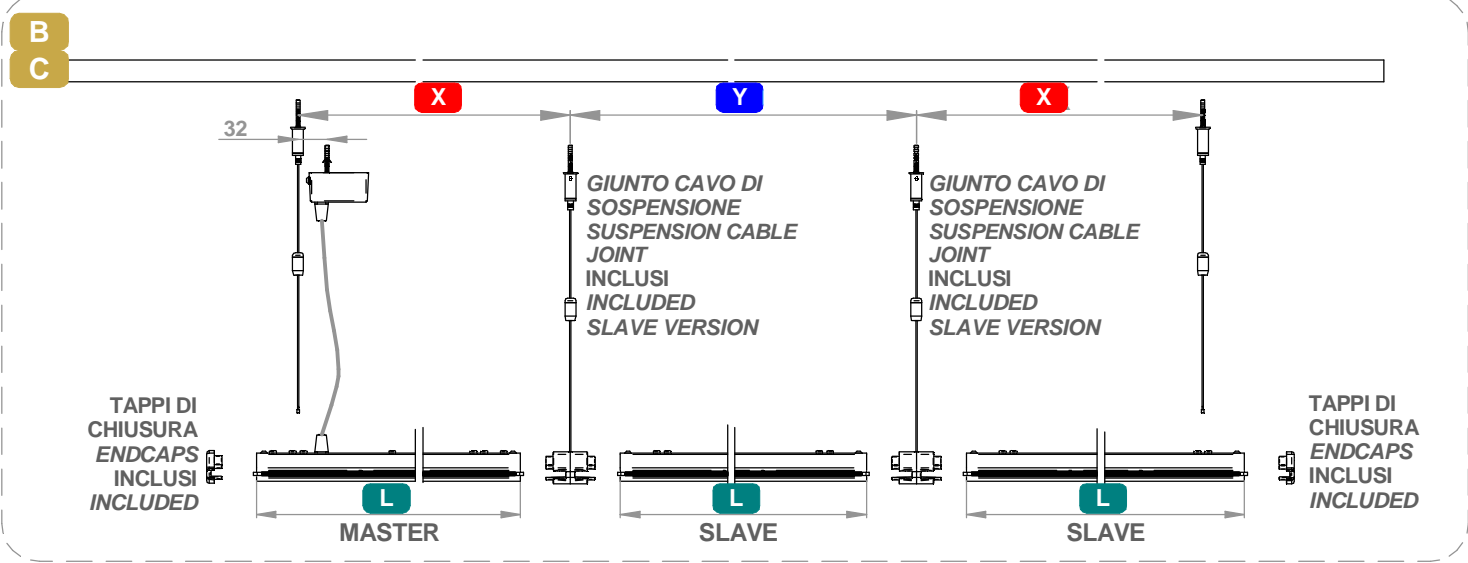
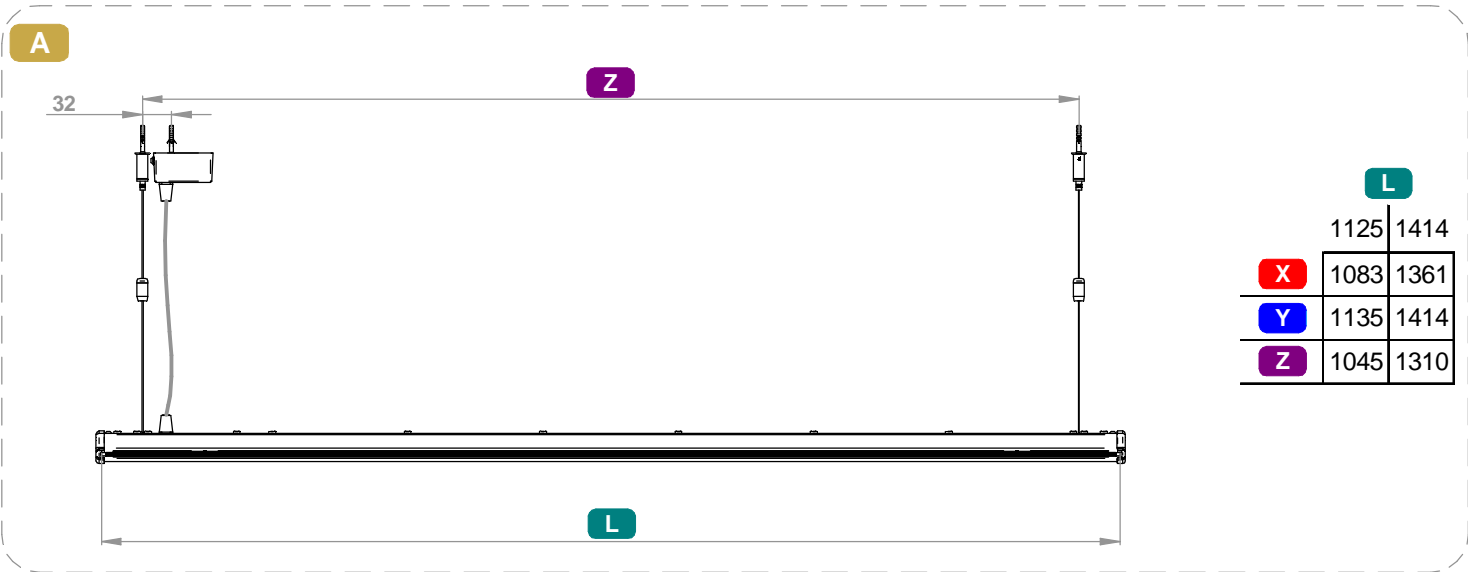

SERIE / SERIES: MINI-ALBATROS

BRAND: i-L^{ED}

INSTALLAZIONE / INSTALLATION

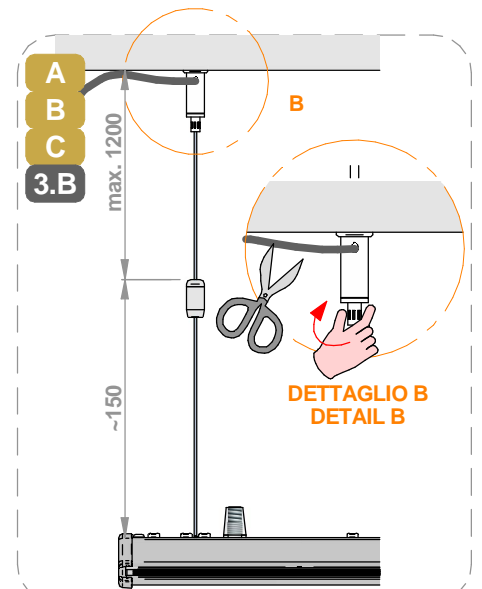
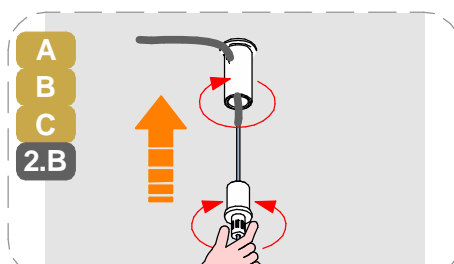
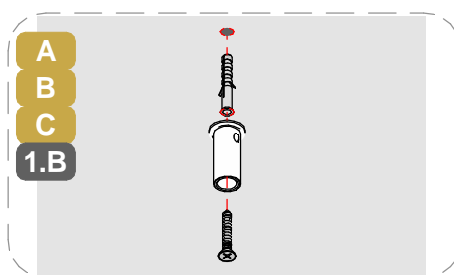
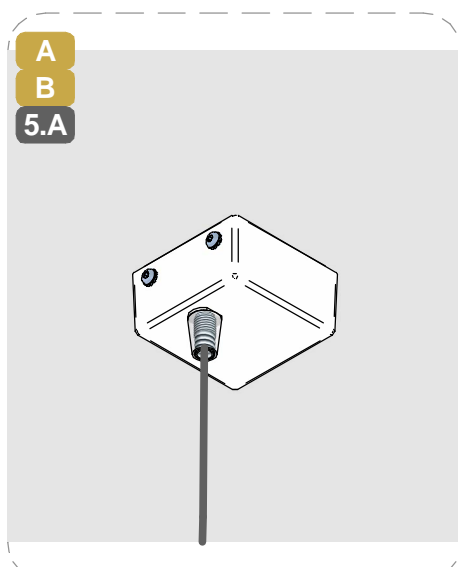
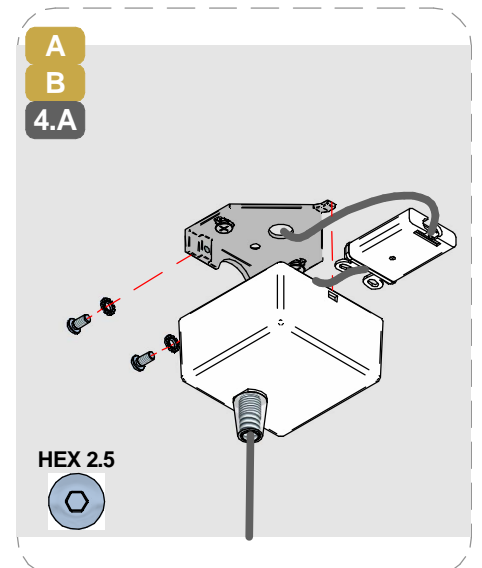
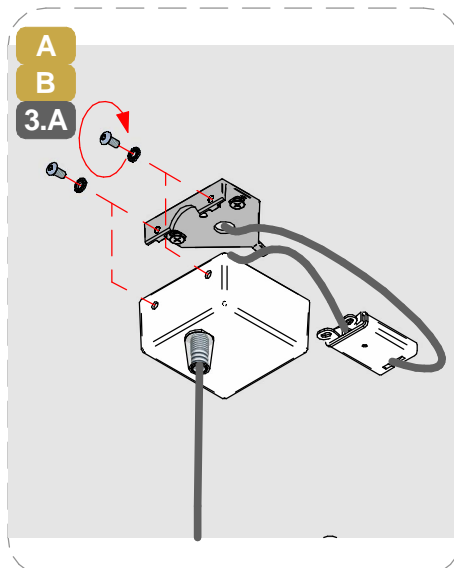
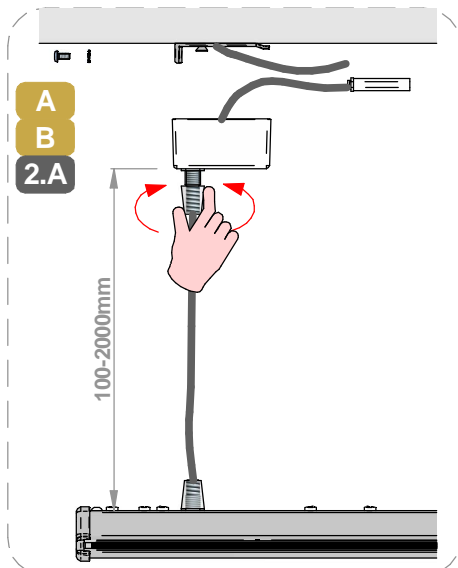
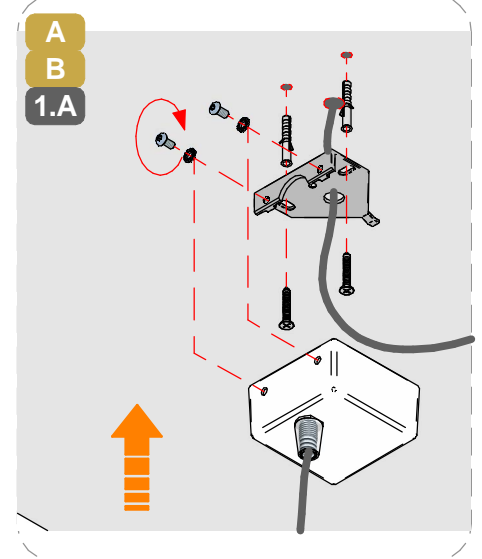
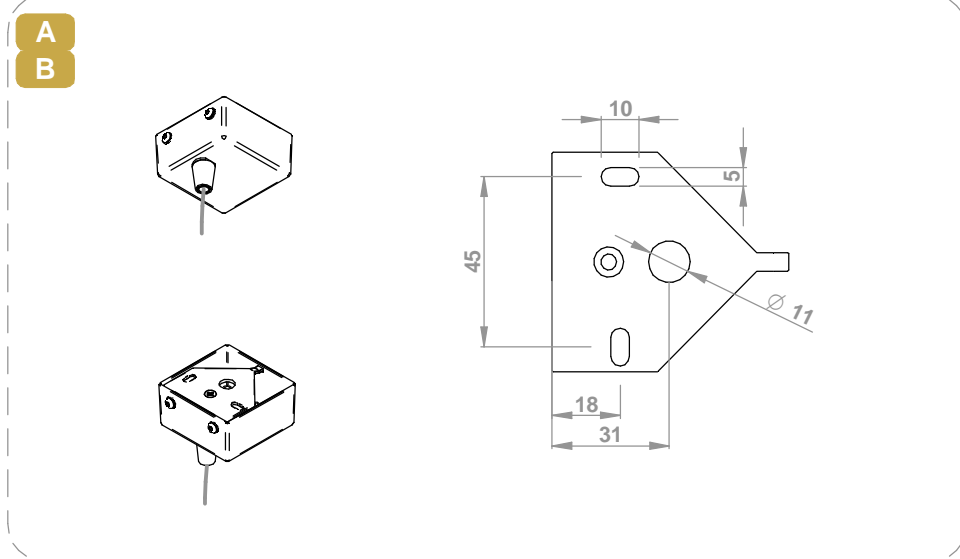

SERIE / SERIES: MINI-ALBATROS

BRAND: i-L^èD

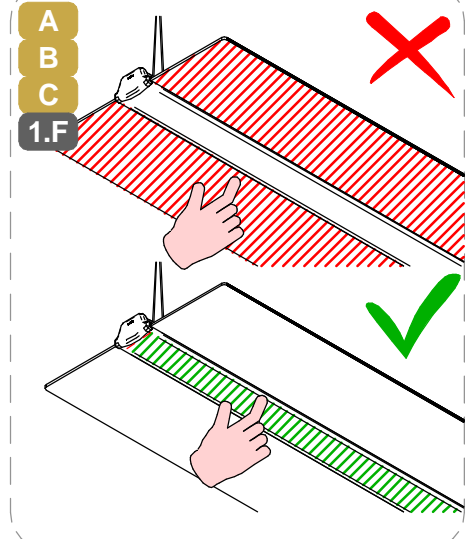
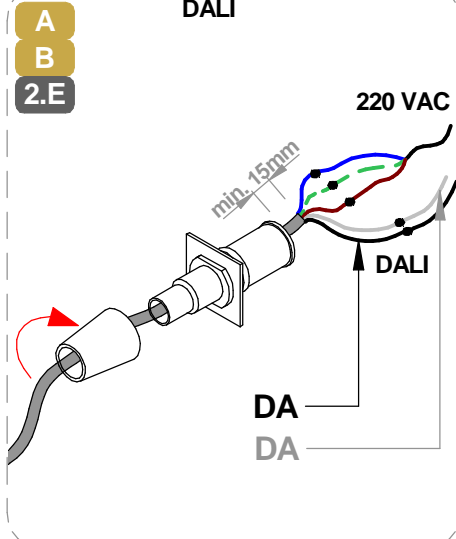
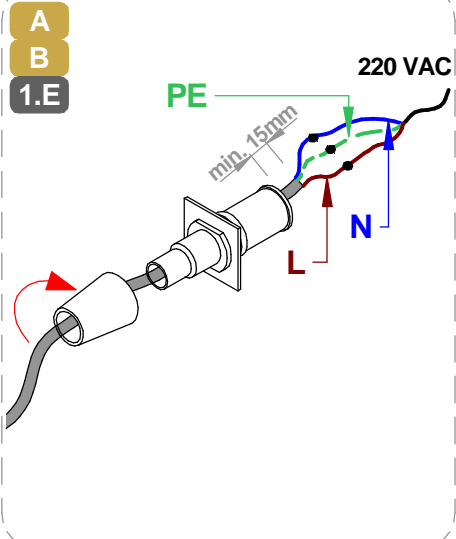
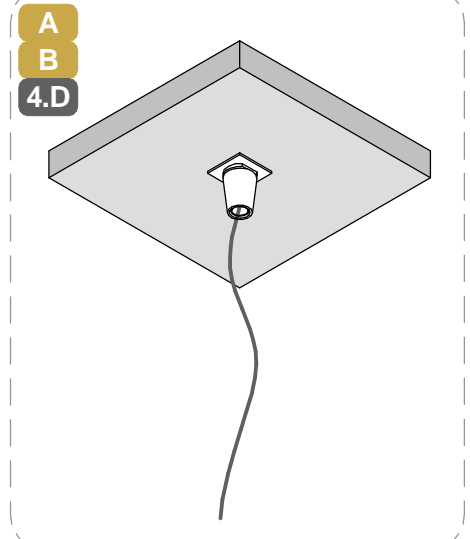
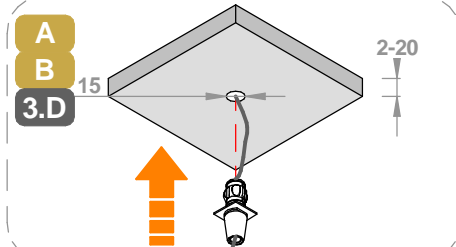
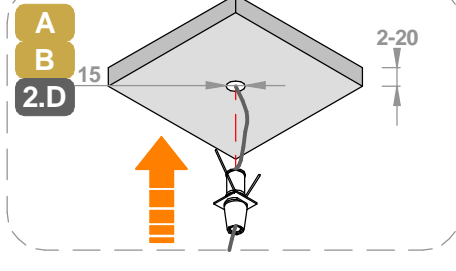
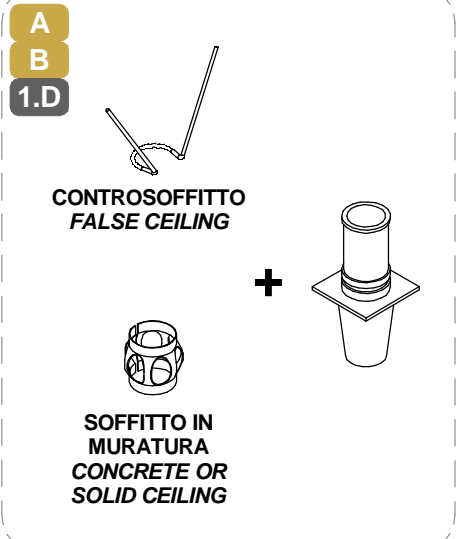
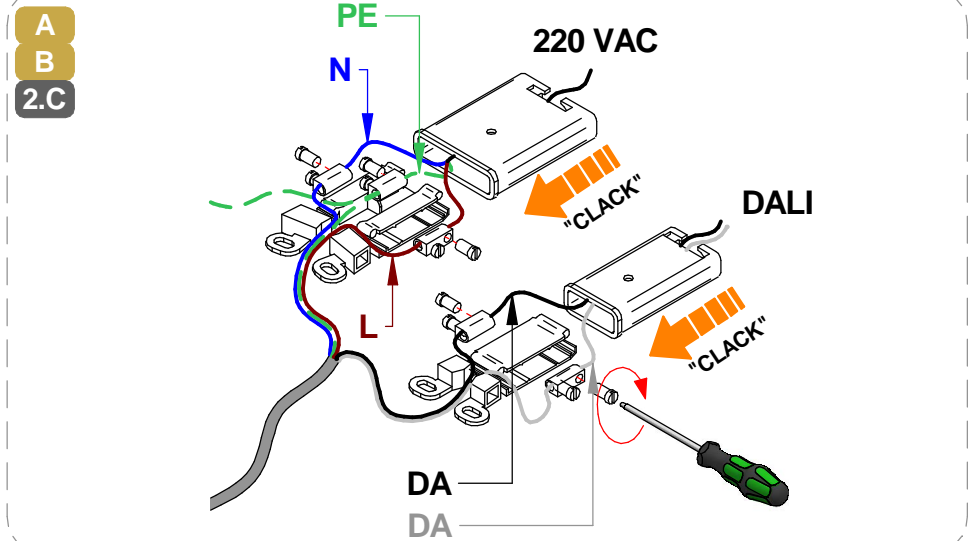
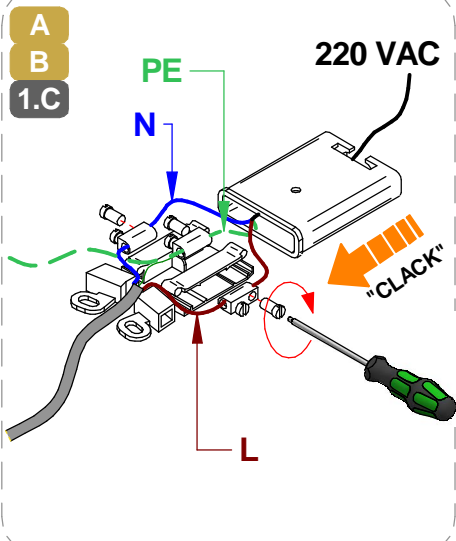

SERIE / SERIES: MINI-ALBATROS

BRAND: i-L^{ED}

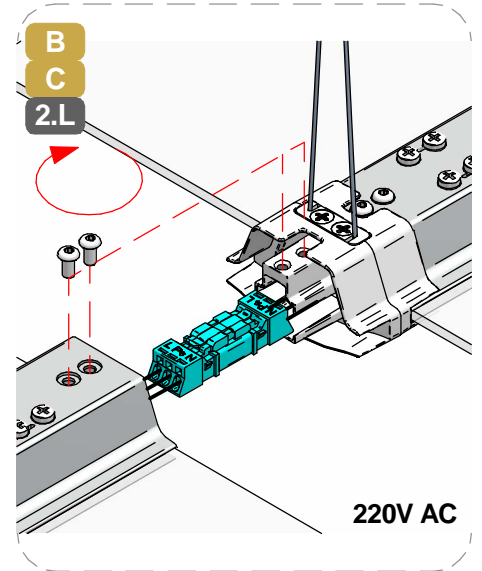
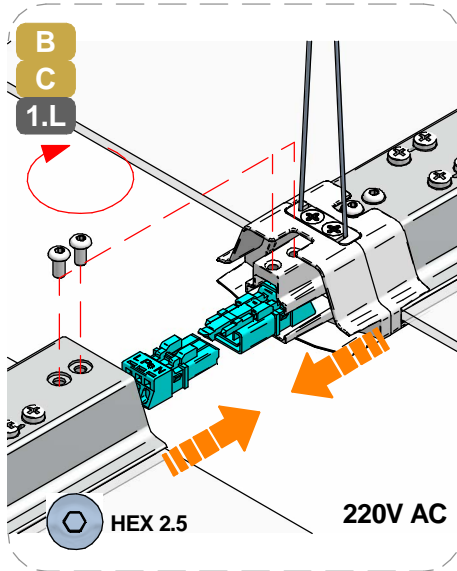
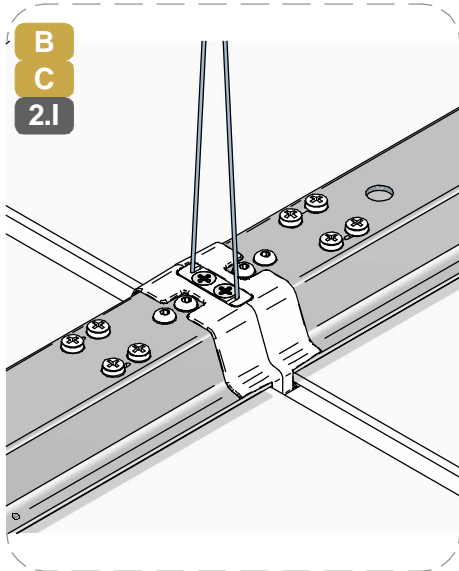
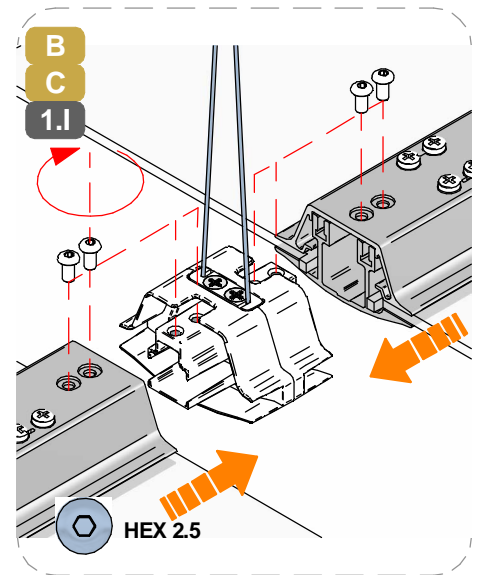
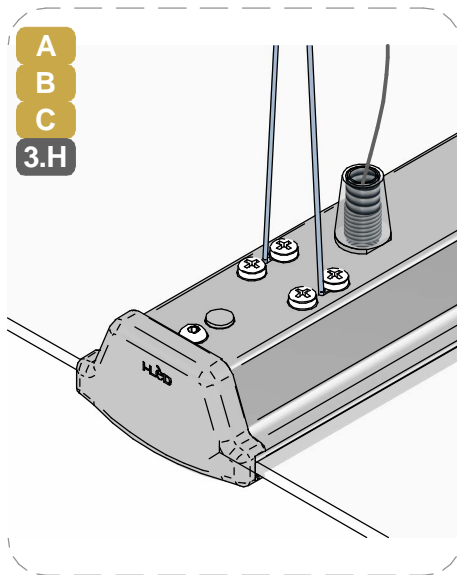
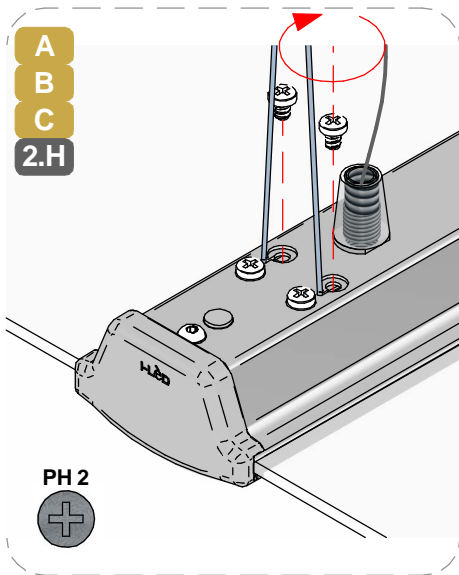
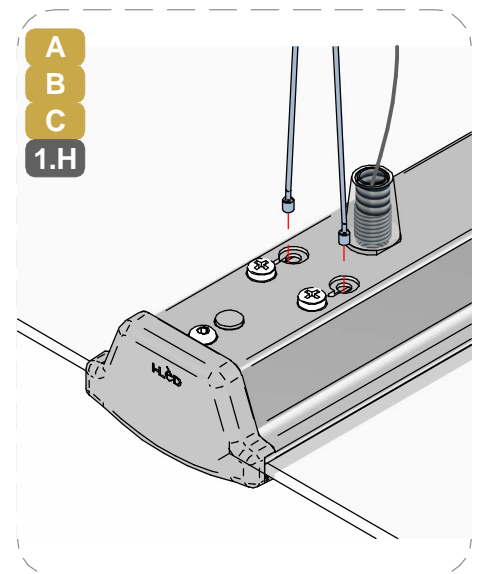
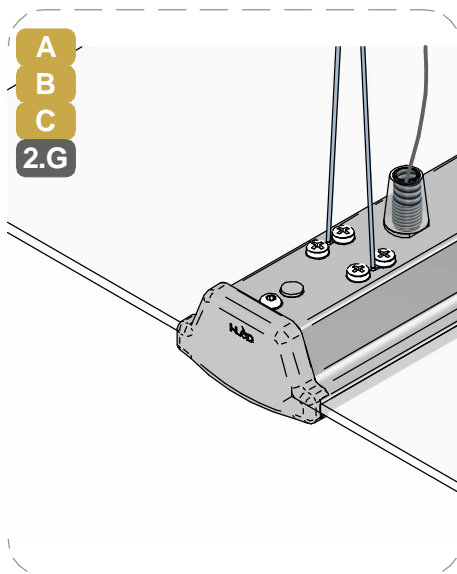
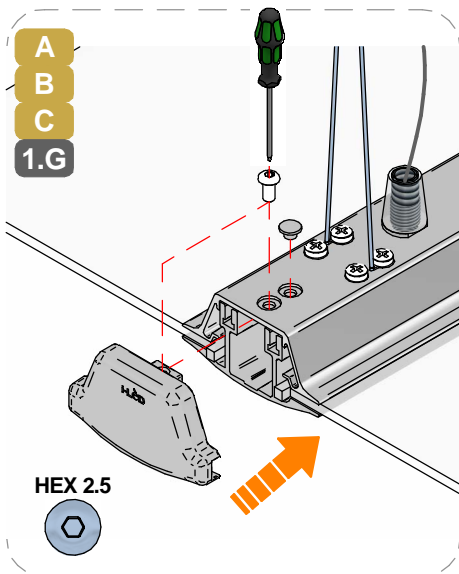

SERIE / SERIES: MINI-ALBATROS

BRAND: i-LED

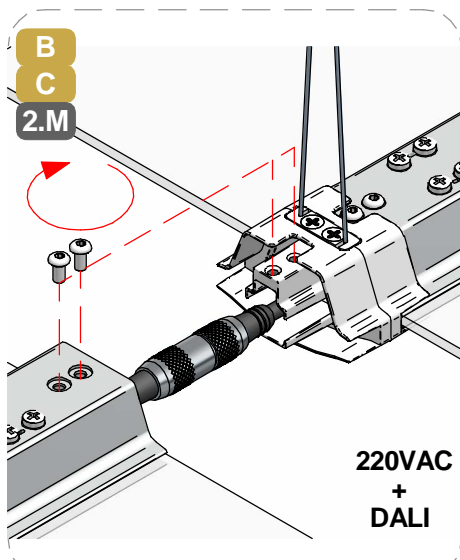
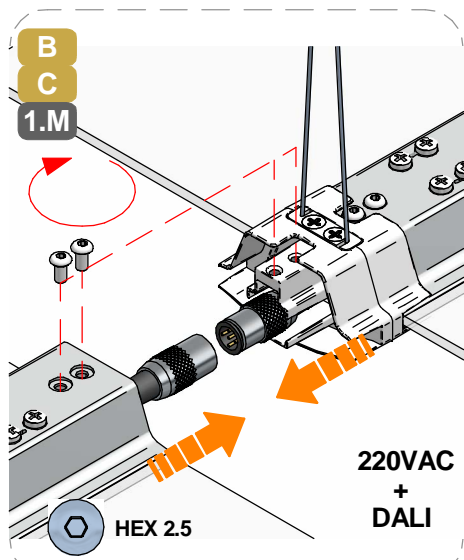

LAVARE LA SUPERFICIE DEL
DIFFUSORE LUCE
CON PANNO UMIDO, UTILIZZANDO
SOLO ACQUA
E SAPONE NEUTRO.

CLEAN THE SURFACE OF THE LIGHT
DIFFUSER
WITH A DAMP CLOTH, USING ONLY
WATER
AND NEUTRAL SOAP

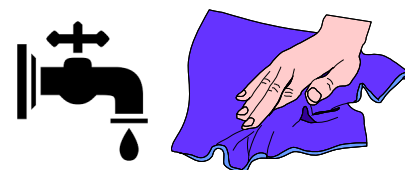

CABLAGGIO / WIRING

1

TUTTE LE OPERAZIONI DI COLLEGAMENTO ALLA RETE ELETTRICA DEVONO ESSERE CONDOTTE IN MANCANZA DI TENSIONE

ALL THE WIRING OPERATION MUST BE PERFORMED WITH MCB IN OFF POSITION

2

SE IL PRODOTTO E' DEFINITO IN CLASSE 1, IL CONDUTTORE DI MESSA A TERRA DI PROTEZIONE DEVE ESSERE SEMPRE COLLEGATO

IF THE FITTING IS CLASS 1 RATED, THE CPC | EARTH | PE CONDUCTOR MUST BE CONNECTED

3

SE L'IMPIANTO E' STATO COMPLETATO ED E' IN SICUREZZA, PUO' ESSERE ALIMENTATO

WHEN THE CIRCUIT IS COMPLETED AND SAFE, MCB CAN BE SET IN ON POSITION



SI PREGA SEGUIRE LE BUONE PRATICHE DI DIMENSIONAMENTO E SEZIONAMENTO DELL'IMPIANTO ELETTRICO, TENENDO PRESENTE: LE CARATTERISTICHE DELL'INTERRUTTORE DIFFERENZIALE ED IL NUMERO DI ARTICOLI COLLEGATI ALLA LINEA ELETTRICA; QUESTO PER AGEVOLARE L'IDENTIFICAZIONE DI EVENTUALI ANOMALIE SULLA LINEA ELETTRICA

PLEASE FOLLOW THE BEST PRACTICES IN ELECTRICAL SYSTEM DESIGN, PAING ATTENTION TO THE RCCB SWITCH CHARACTERISTICS AND THE NUMBER OF FITTINGS CONNECTED TO THE ELECTRICAL LINE; THIS HELPS TO IDENTIFY POSSIBLE ANOMALIES ON THE ELECTRICAL LINE

AC

CORRENTE ALTERNATA
MAX. DISTANZA TRA DRIVER ED ULTIMO PRODOTTO | SEZIONE CAVO ALTERNATE CURRENT DRIVER TO LAST LIGHT FITTING MAX DISTANCE | WIRE SECTION

SEZIONE SECTION [mm ²]	1	1,5	2,5
LUNGHEZZA LENGHT [m]	50	75	130

* Distanza massima dal driver all'ultimo articolo della linea a massimo carico.
Per lunghezze massime dei cavi effettive, fare riferimento a support@linealight.com
* Maximum distance between LED driver and last device at full load.
For effective maximum cable lengths, please refer to support@linealight.com

TIPO DI CONNESSIONE TYPE OF CONNECTION

X: Se il cavo flessibile esterno di questo apparecchio è danneggiato, deve essere sostituito da un cavo speciale, disponibile esclusivamente presso il fabbricante, o il suo servizio di assistenza.
X: If the external flexible cable of this appliance is damaged, it must be replaced with a special cable, which is only available from the manufacturer or its service department.

Y: Se il cavo flessibile esterno di questo apparecchio è danneggiato, deve essere sostituito esclusivamente dal fabbricante, dal suo servizio di assistenza o da personale qualificato equivalente, al fine di evitare pericoli.
Y: If the external flexible cable of this appliance is damaged, it must only be replaced by the manufacturer, its service department or equivalent qualified personell in order to avoid danger.

Z: Il cavo flessibile esterno di questo apparecchio non può essere sostituito; se il cavo è danneggiato l'apparecchio deve essere distrutto.
Z: The external flexible cable fo this appliance cannot be replaced; if the cable is damaged, the appliance must be destroyed.



Per ridurre il rischio di strangolamento, il cavo flessibile collegato all'apparecchio deve essere efficacemente fissato alla parete, se si trova all'interno del volume di accessibilità.
To reduce the risk of strangulation, the flexible cable connected to the device must be securely fixed to the wall if it is located within the accessible area.

SERIE / SERIES: MINI-ALBATROS

BRAND: i-LèD

MARRONE / BROWN = LINEA / LINE

AZZURRO / LIGHT BLUE = NEUTRO / NEUTRAL

GIALLO-VERDE / YELLOW-GREEN = TERRA / EARTH CPC | PE

CABLAGGIO IN PARALLELO | PARALLEL WIRING
TENSIONE DI RETE / MAINS VOLTAGE

AC

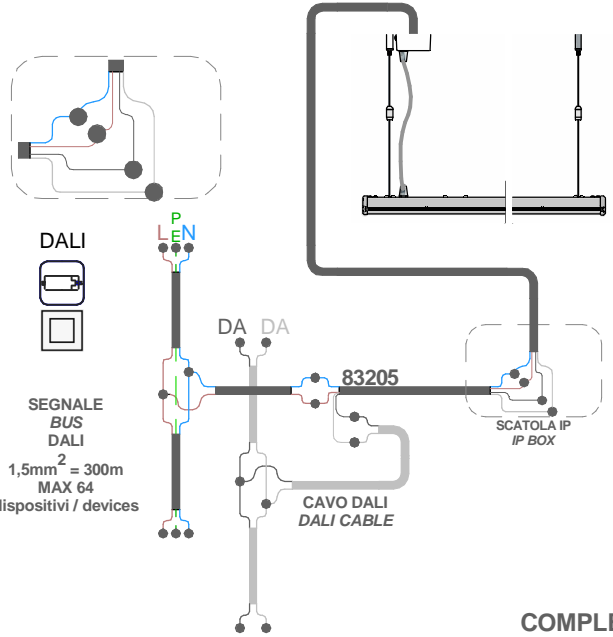
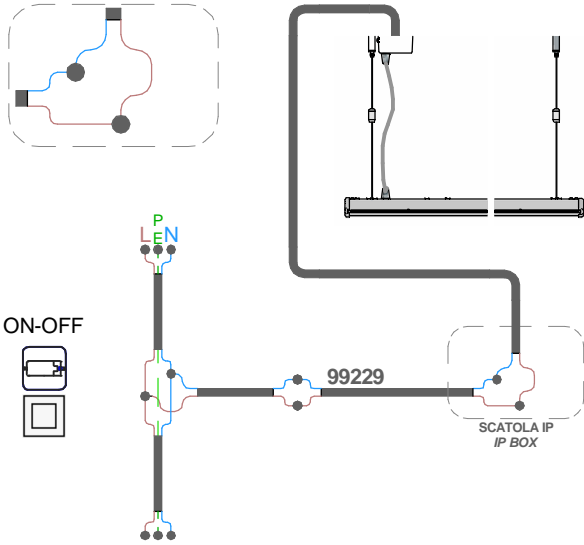

COMPLETE

COMPLETE

MASTER + SLAVE

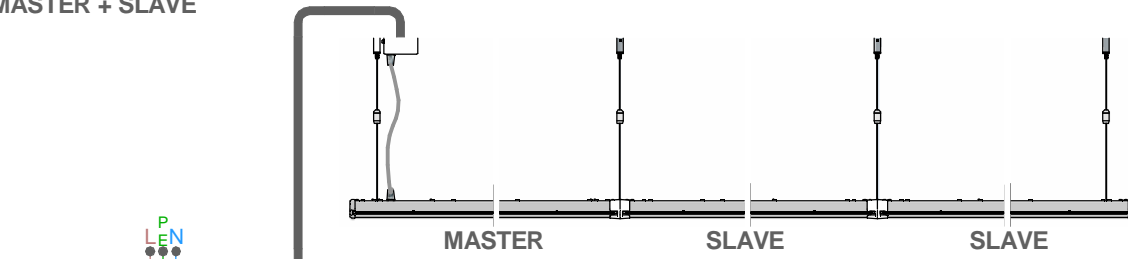

N° MAX DEVICES

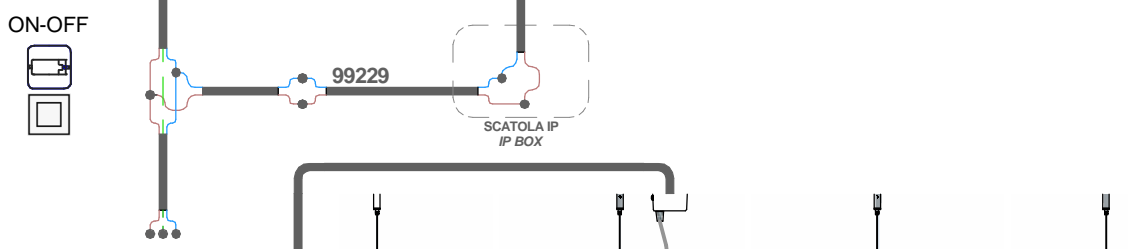

N° MAX DEVICES

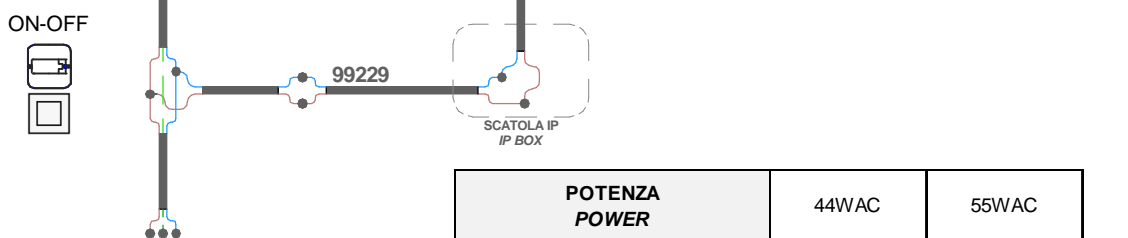

POTENZA POWER	44WAC	55WAC
LUNGHEZZA LENGHT	1125 mm	1414 mm
N° MAX DEVICES	10	8

SERIE / SERIES: MINI-ALBATROS

BRAND: i-LèD

MARRONE / BROWN = LINEA / LINE

AZZURRO / LIGHT BLUE = NEUTRO / NEUTRAL

GIALLO-VERDE / YELLOW-GREEN = TERRA / EARTH CPC | PE

MASTER + SLAVE

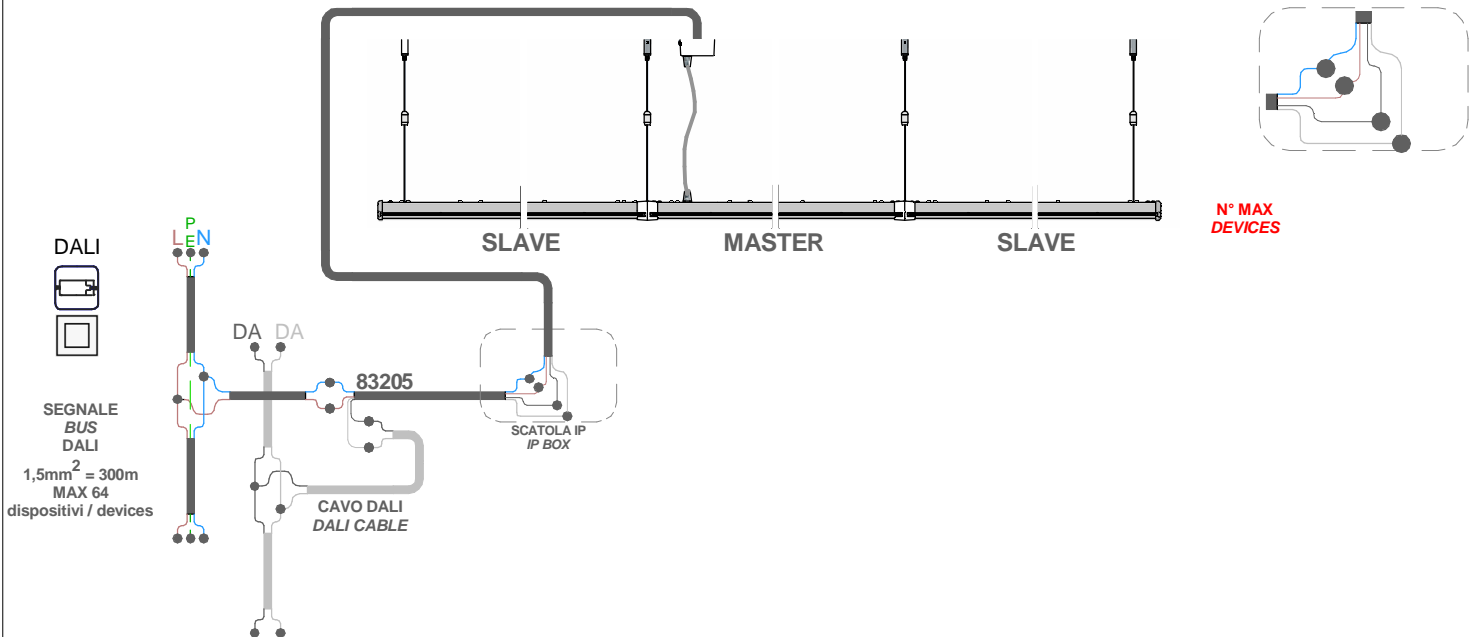
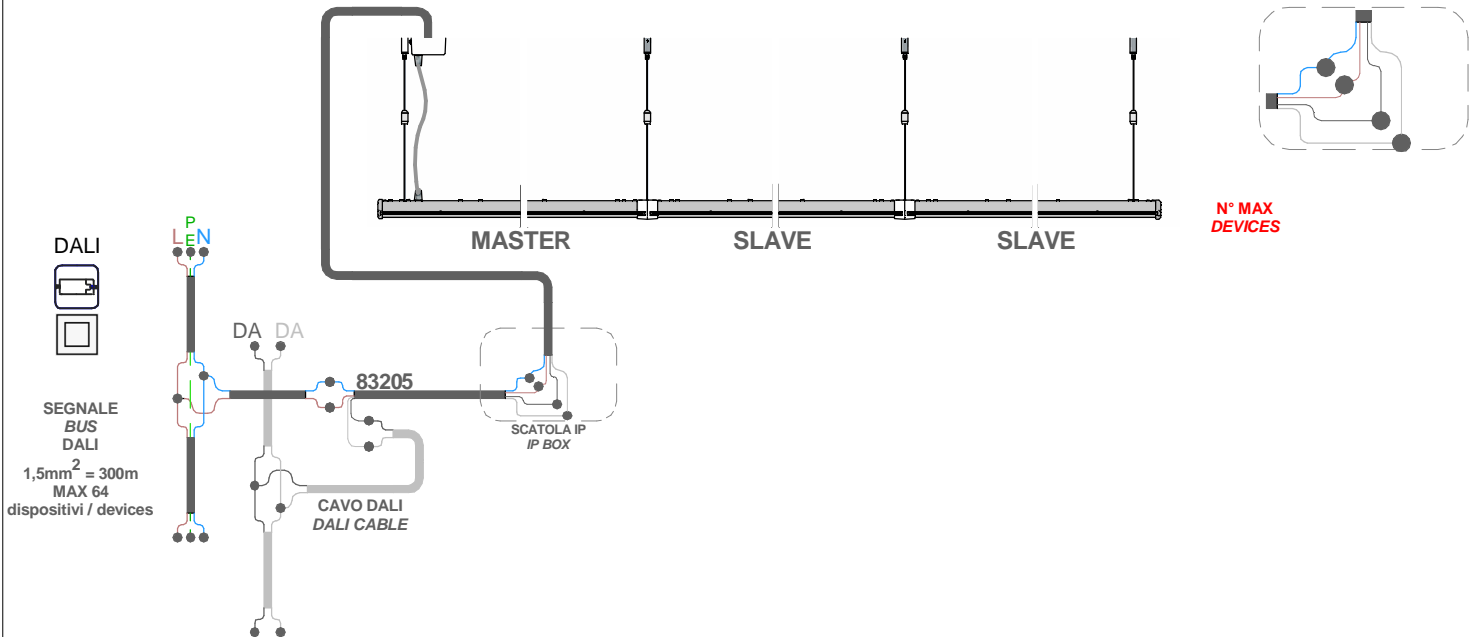

CAVO DALI / DALI CABLE

- DALI
- NERO / BLACK = DALI 1
 - BIANCO / WHITE = DALI 2

POTENZA POWER	44WAC	55WAC
LUNGHEZZA LENGHT	1125 mm	1414 mm
N° MAX DEVICES	10	8