

SERIE / SERIES: CELL, CELL WW

BRAND: i-L^èD

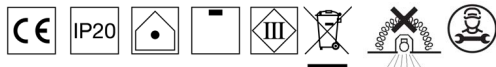

A

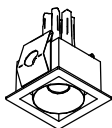

C00148

B

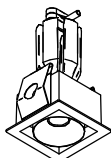

C00149

C

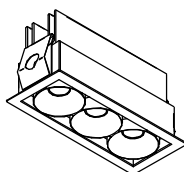

C00150

D

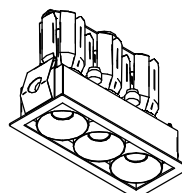

C00151

E

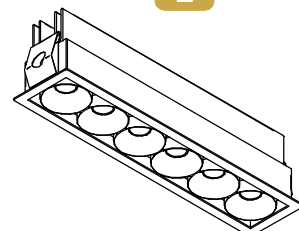

C00152

F

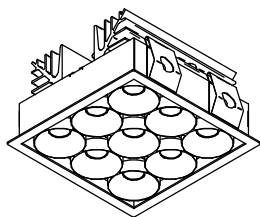

C00148

G

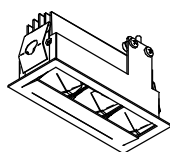

82600
82940

H

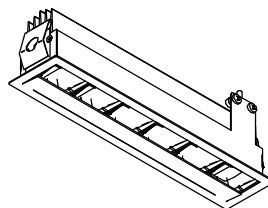

82601
82941

I

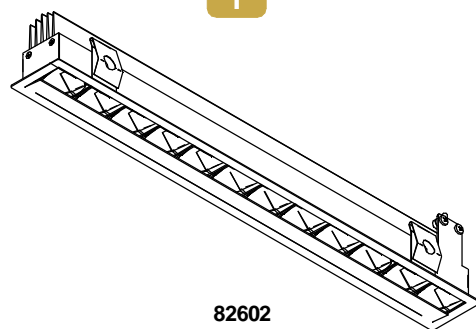

82602
82942

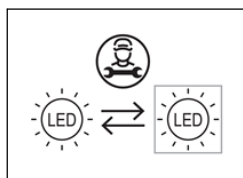

CODICI / CODES

CCT [K°] - Energy Class

CODE	Dimensions [mm]	Power [W]	Voltage [V]	Current [mA]	Weight [Kg]	Safety Class	IP	CRI	CCT [K°] - Energy Class			N° Light Source
									2700	3000	4000	
C00148	□50x67	2	4	630		3	20	90	E	E	E	1
C00149	□50x91	4	4	350		3	20	90	E	E	E	1
C00150	50 x 119 x 62	6	6	630		3	20	90	E	E	E	1
C00151	50 x 119 x 98	12	12	350		3	20	90	E	E	E	1
C00152	50 x 222 x 68	6	12	630		3	20	90	E	E	E	1
C00153	□129 x 70	12	18	350		3	20	90	E	E	E	1
82600, 82940	50 x 120 x 67	12	9,5	350		3	20	90	E	E	E	1
82601, 82941	50 x 227 x 67	12	18	630		3	20	90	E	E	E	1
82602, 82942	50 x 439 x 67	18	32,5	630		3	20	90	E	E	E	1

Ta -20°C ÷ +50°C

SERIE / SERIES: CELL, CELL WW

BRAND: i-LèD

DIMENSIONI / DIMENSIONS

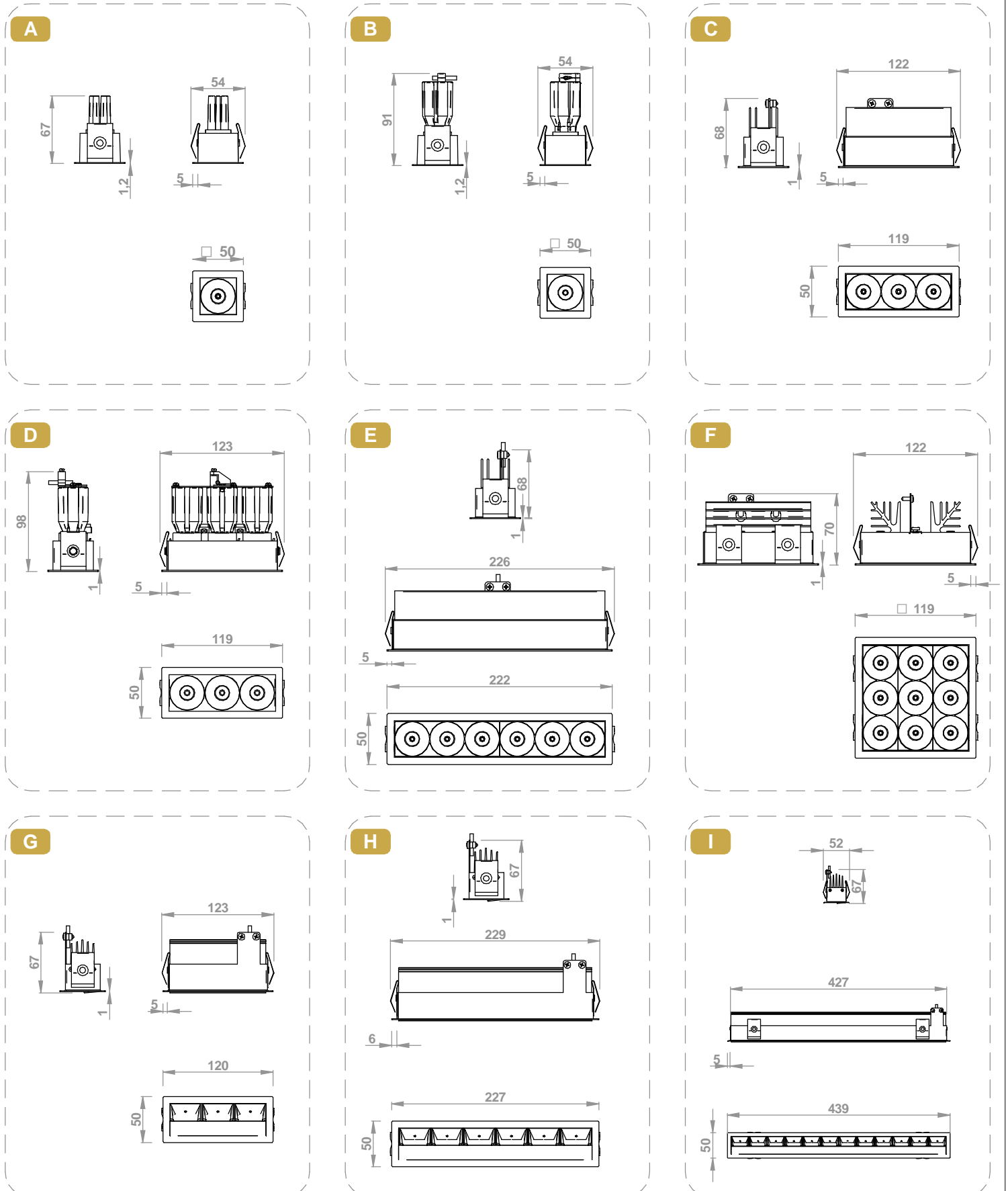

SERIE / SERIES: CELL, CELL WW

BRAND: i-LèD

PRE-INSTALLAZIONE / PRE-INSTALLATION

INSTALLAZIONE / INSTALLATION

CODICE **X** **Y**
CODE [mm] [mm]

C00148	44	44
C00149	44	44
C00150	113	42
C00151	113	42
C00152	215	42
C00153	113	113
82600, 82940	114	40
82601, 82941	219	40
82602, 82942	432	42

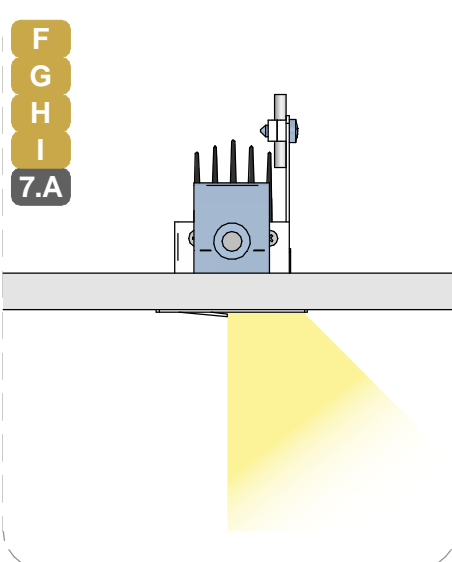
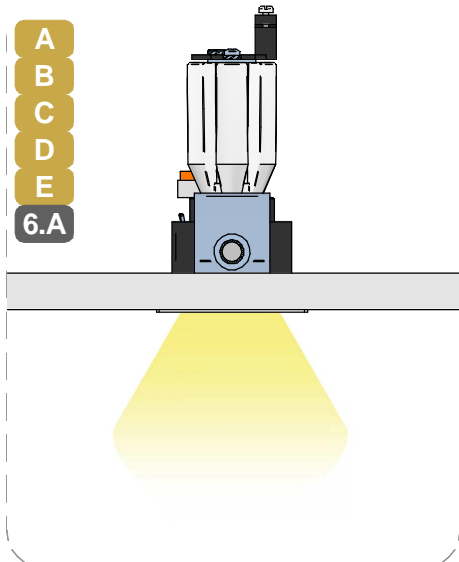
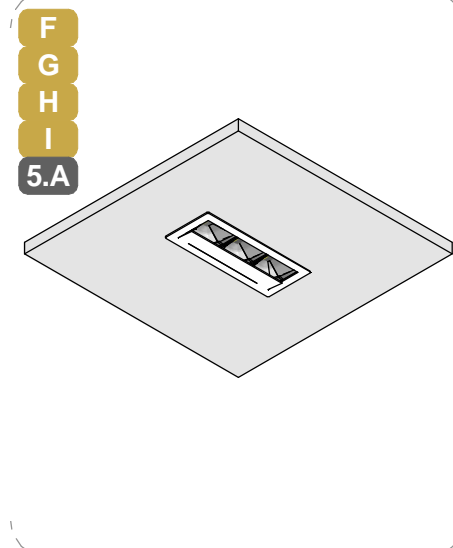
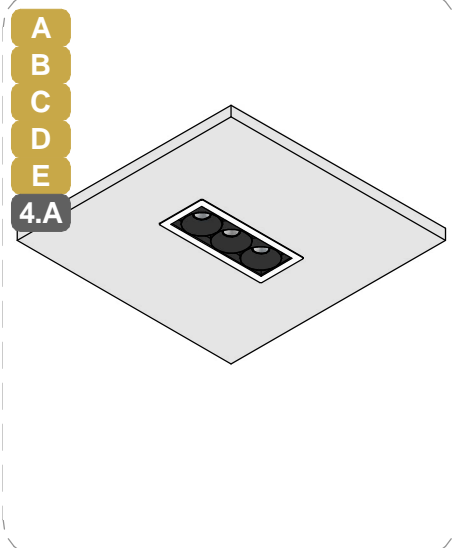
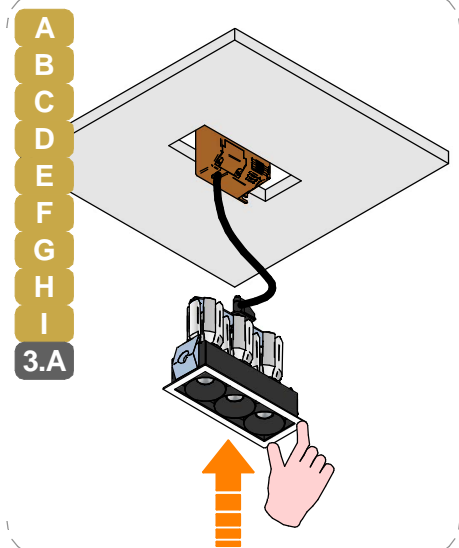
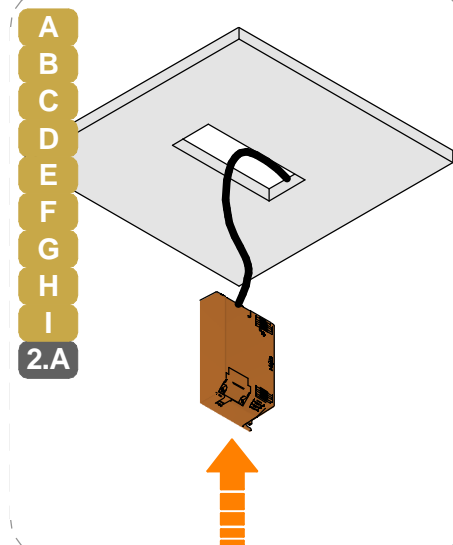
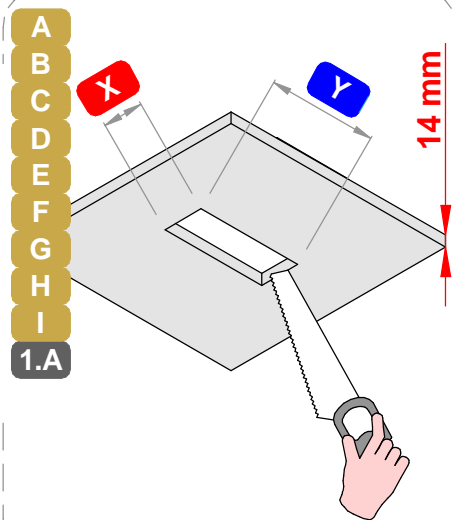

SERIE / SERIES: CELL, CELL WW

BRAND: i-L^{ED}

MARRONE / BROWN = LINEA / LINE

AZZURRO / LIGHT BLUE = NEUTRO / NEUTRAL

GIALLO-VERDE / YELLOW-GREEN = TERRA / EARTH CPC | PE

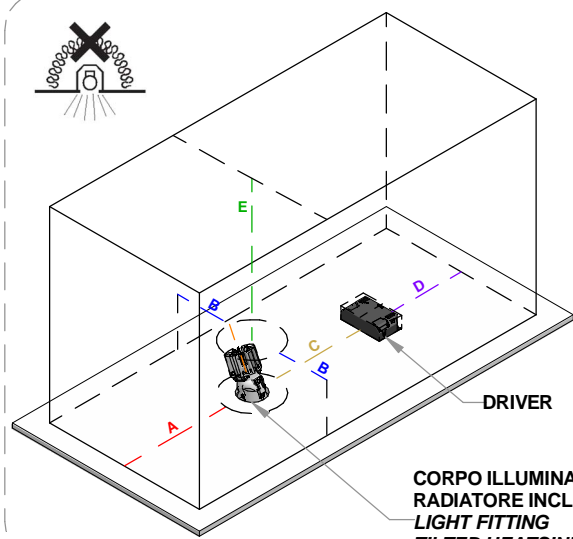

PER UN'INSTALLAZIONE SICURA, E' OBBLIGATORIO SEGUIRE LE DISTANZE SPECIFICATE

IT'S MANDATORY TO FOLLOW THESE DIMENSIONS FOR A SAFE INSTALLATION

DIM.	[mm]
A	100
B	100
C	100
D	100
E	100

CORPO ILLUMINANTE CON RADIATORE INCLINATO
LIGHT FITTING TILTED HEATSINK

CABLAGGIO / WIRING

1 TUTTE LE OPERAZIONI DI COLLEGAMENTO ALLA RETE ELETTRICA DEVONO ESSERE CONDOTTE IN MANCANZA DI TENSIONE
ALL THE WIRING OPERATION MUST BE PERFORMED WITH MCB IN OFF POSITION

2 SE IL PRODOTTO E' DEFINITO IN CLASSE 1, IL CONDUTTORE DI MESSA A TERRA DI PROTEZIONE DEVE ESSERE SEMPRE COLLEGATO
IF THE FITTING IS CLASS 1 RATED, THE CPC / EARTH | PE CONDUCTOR MUST BE CONNECTED

3 SE L'IMPIANTO E' STATO COMPLETATO ED E' IN SICUREZZA, PUO' ESSERE ALIMENTATO
WHEN THE CIRCUIT IS COMPLETED AND SAFE, MCB CAN BE SET IN ON POSITION



SE IL PRODOTTO E' DEFINITO IN CLASSE 3, IL CIRCUITO SECONDARIO A BASSA TENSIONE DEVE ESSERE COLLEGATO ALL'ALIMENTATORE PRIMA CHE QUESTO SIA SOTTO TENSIONE

IF THE FITTING IS CLASS 3 RATED, THE LOW VOLTAGE CIRCUIT MUST BE WIRED BEFORE THE POWER SUPPLY IS POWERED ON

SE IL CARICO VENISSE COLLEGATO AD ALIMENTATORE SOTTO TENSIONE, I PRODOTTI POTREBBERO DANNEGGIARSI, SUBENDO UN DANNO DA SOVRATENSIONE
IF THE LOAD IS WIRED TO AN ALREADY ON POWER SUPPLY, THE FITTINGS COULD BE DAMAGED BY VOLTAGE SURGE

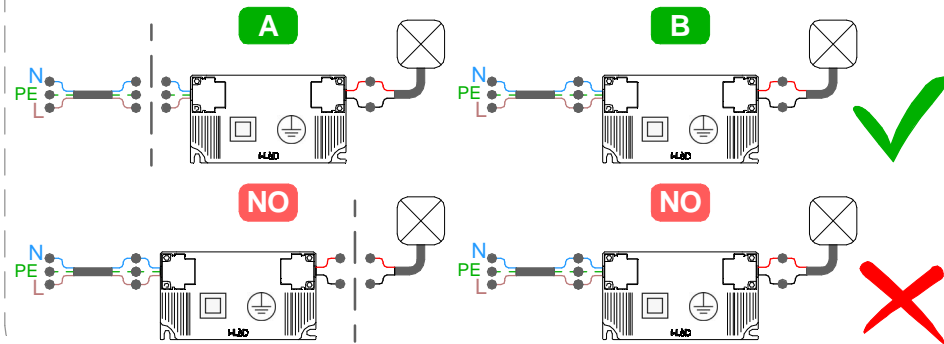

MCB

N° DI PRODOTTI PER MAGNETOTERMICO

N° OF LIGHT FITTINGS PER MCB

CODICE CODE	B10	B16	B20	C10	C16	C20
89147	65	105	131	109	175	219
89145	65	105	131	109	175	219
99126	55	89	111	92	148	185
99129	55	89	111	92	148	185
99376	49	79	99	81	131	164
99375	49	79	99	81	131	164
99105	22	36	44	37	59	74
99115	22	36	45	38	61	76
C-E100001	42	67	85	49	79	98
C-E100010	139	223	279	162	261	326
C-E100011	139	223	279	162	261	326
C-E100001	42	67	85	49	79	98
83322	61	98	122	71	114	142

CC

N° DI PRODOTTI PER ALIMENTATORE
N° OF LIGHT FITTINGS PER DRIVER

N° MAX DEVICES

TIPO TYPE	ON-OFF							0/1-10V + 89408 24V CV		0/1-10V	DALI + 89408 24V CV	DALI2 PUSH			DALI2 PUSH 0/1-10V	
CODE	89147	89145	99126	99129	99376	99375	99105	99710	99708	99115	99713	83322	C-E100001	C-E100010	C-E100011	83008
C00148	1-2				3-6		6-12	1-3			1-3					
C00149		1				2-3								1	1	
C00150					1-2		2-4		1	1-3			2-4			
C00151						1				1		1				
C00152				1			1-2			1			1-2			
C00153							1			1			1			
82600, 82940			1							1			1			
82601, 82941							1						1			1
82602, 82942																1

SERIE / SERIES: CELL, CELL WW

BRAND: i-LèD

MARRONE / BROWN = LINEA / LINE

AZZURRO / LIGHT BLUE = NEUTRO / NEUTRAL

GIALLO-VERDE / YELLOW-GREEN = TERRA / EARTH CPC | PE

CABLAGGIO IN SERIE | CORRENTE COSTANTE
SERIES WIRING | CONSTANT CURRENT

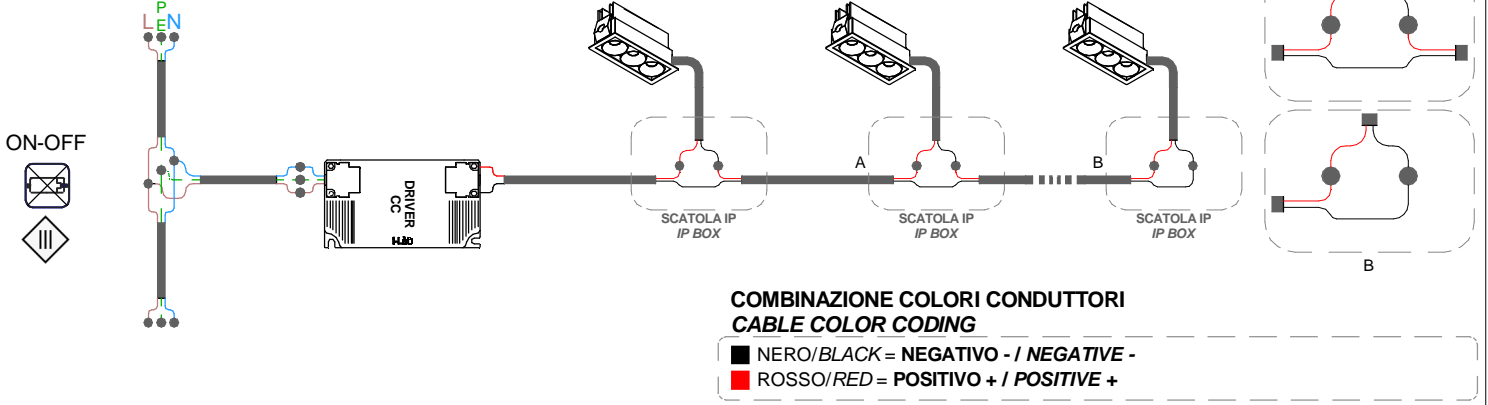

CABLAGGIO IN SERIE | CORRENTE COSTANTE
SERIES WIRING | CONSTANT CURRENT

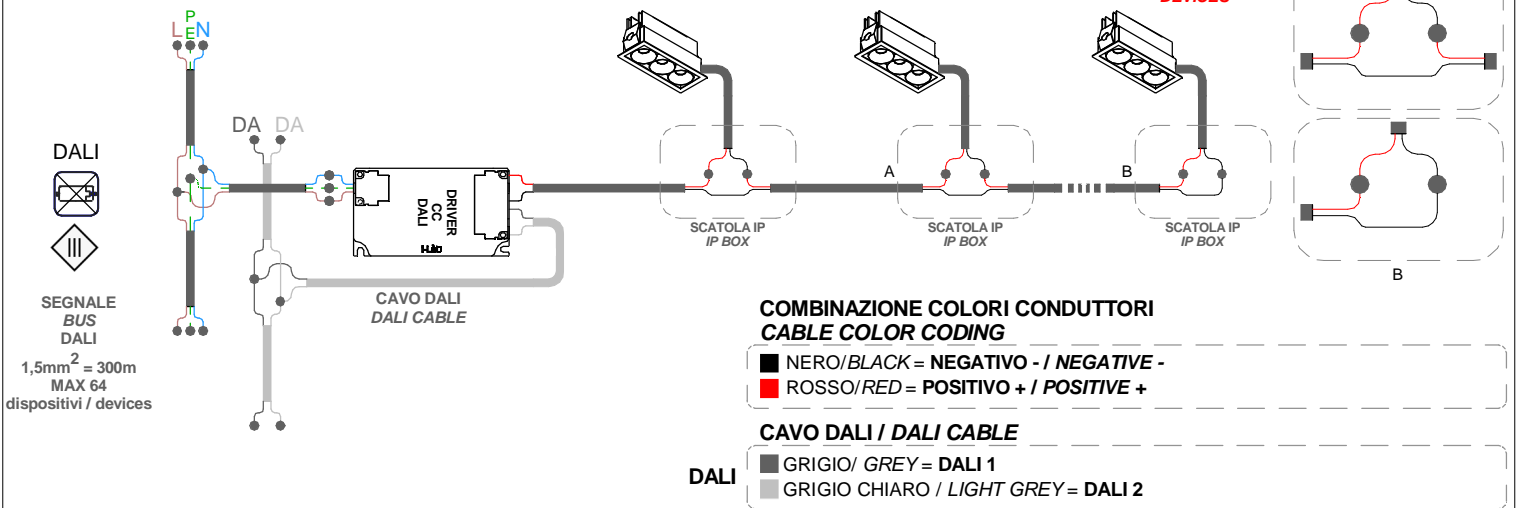

CABLAGGIO IN SERIE | CORRENTE COSTANTE
SERIES WIRING | CONSTANT CURRENT

