

CODE	LENGTH L(mm)	EMISSION	L1	L2	L3
65260 - 65261	1005	Mono Emission	22	19,00	922,00
65262 - 65263	1505	Mono Emission	22	19,00	1422,00
65264 - 65265	2005	Mono Emission	22	19,00	1922,00

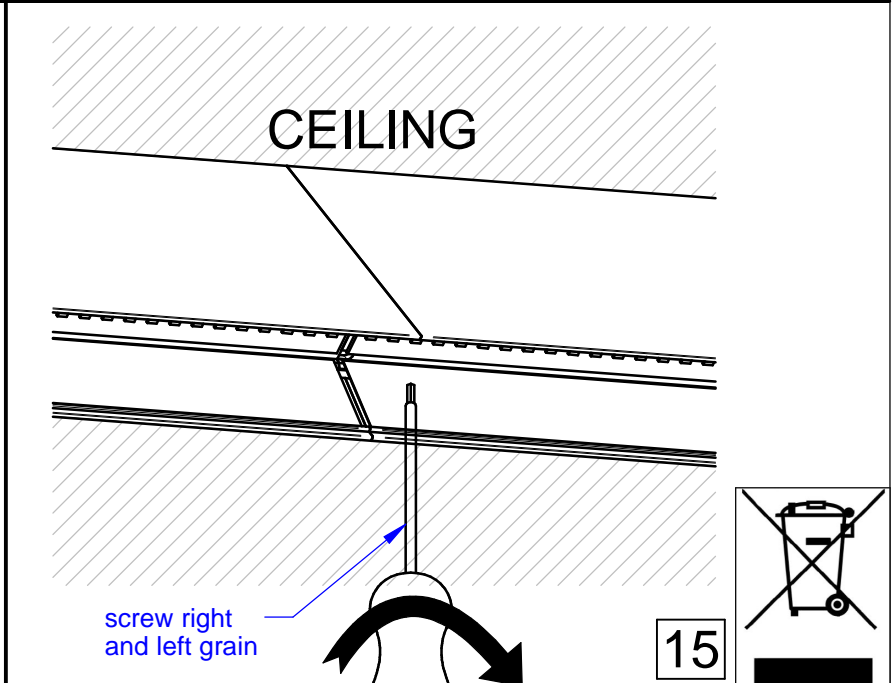

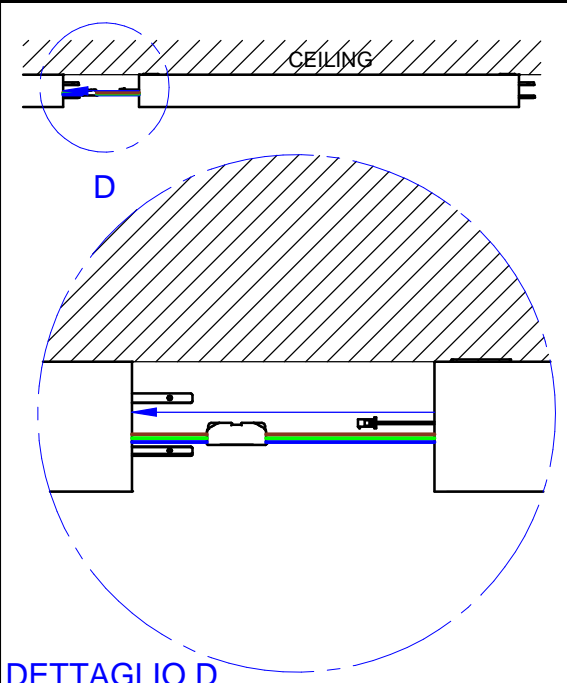

16

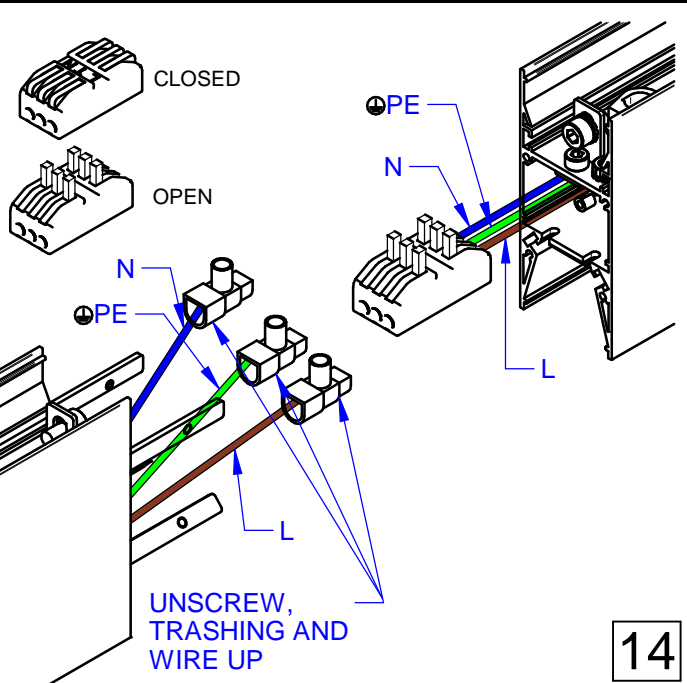
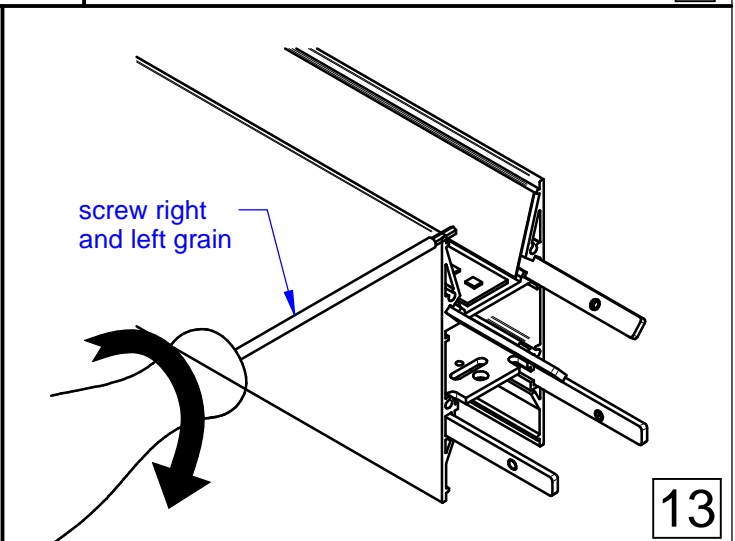
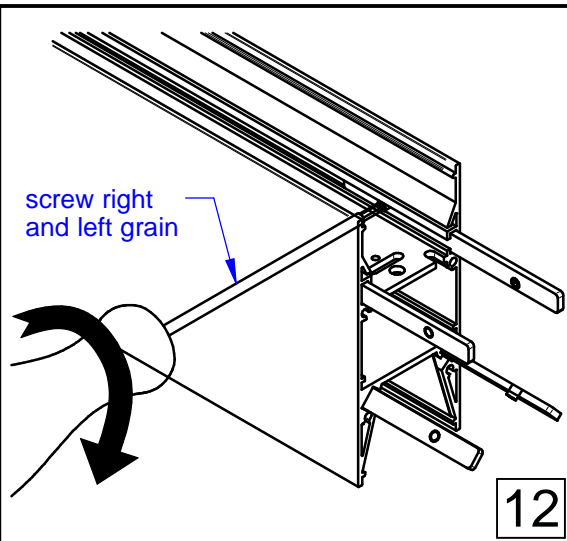
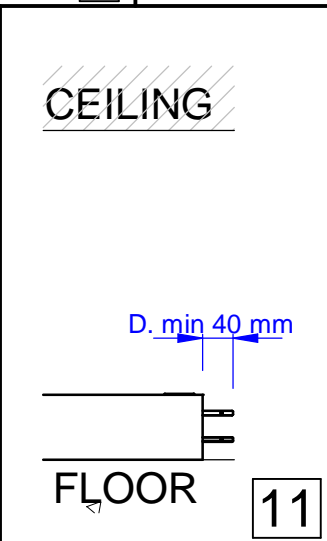
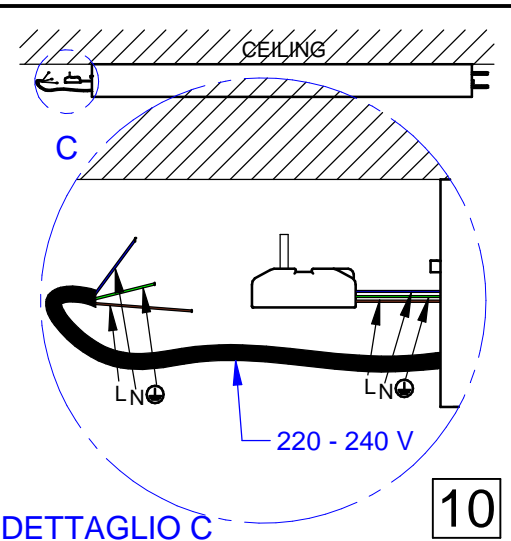
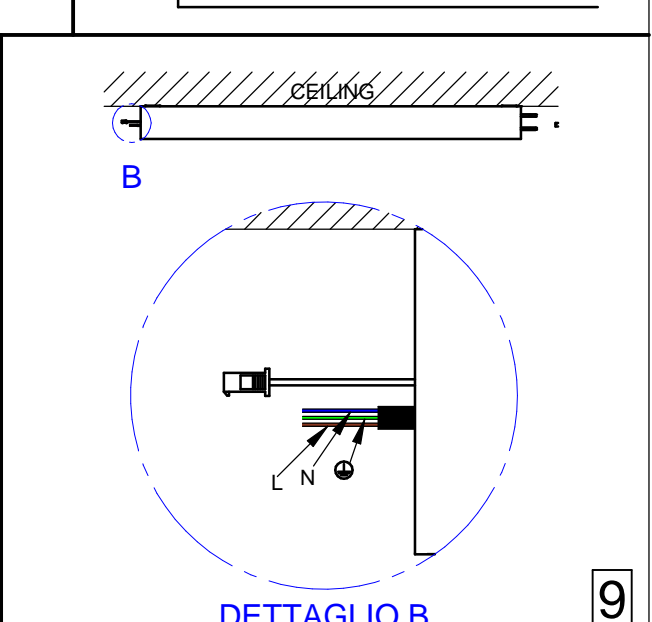
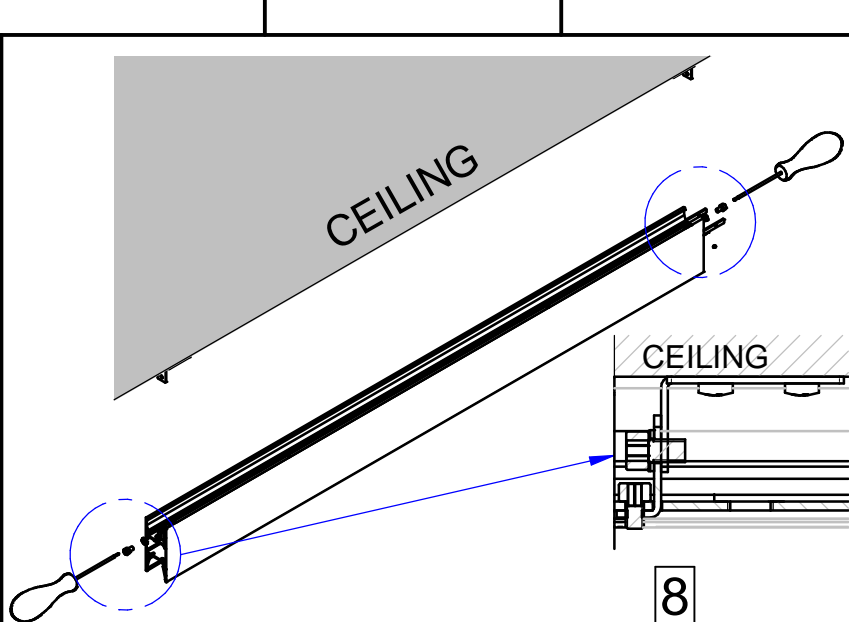
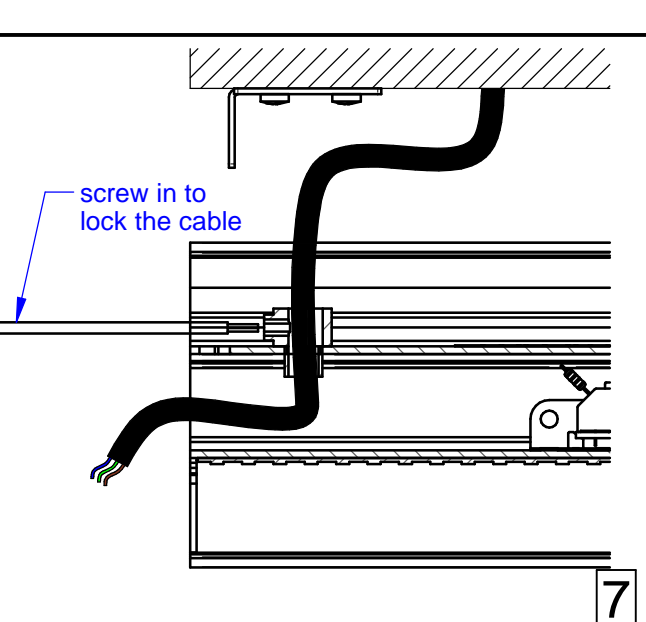
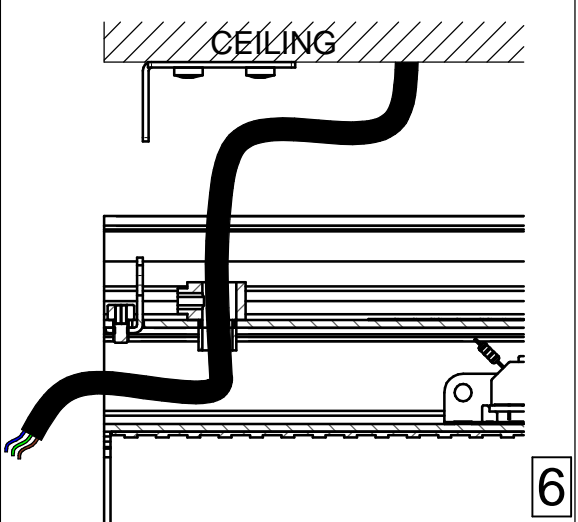
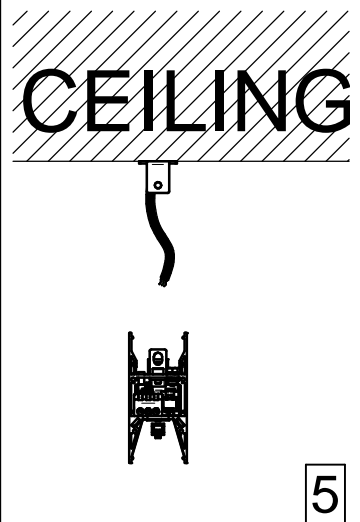
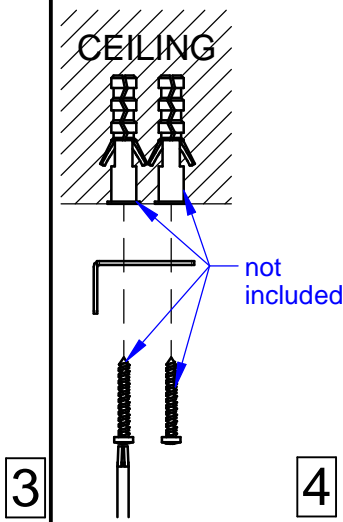
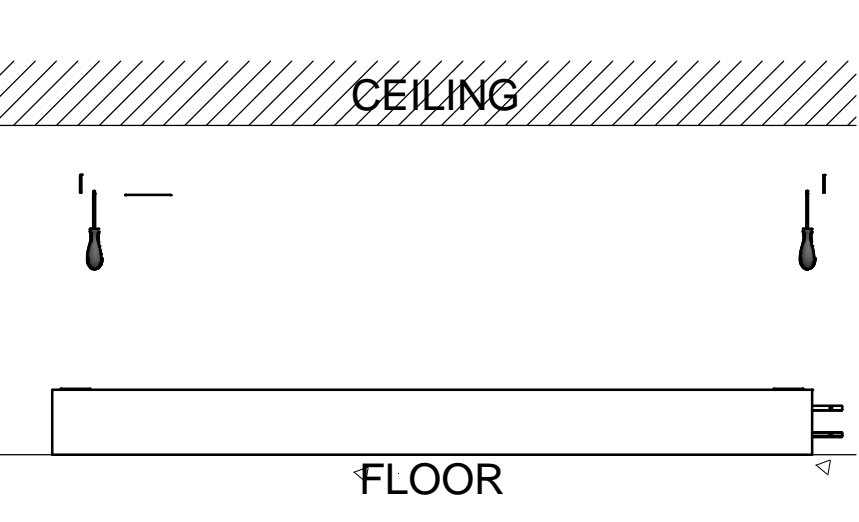
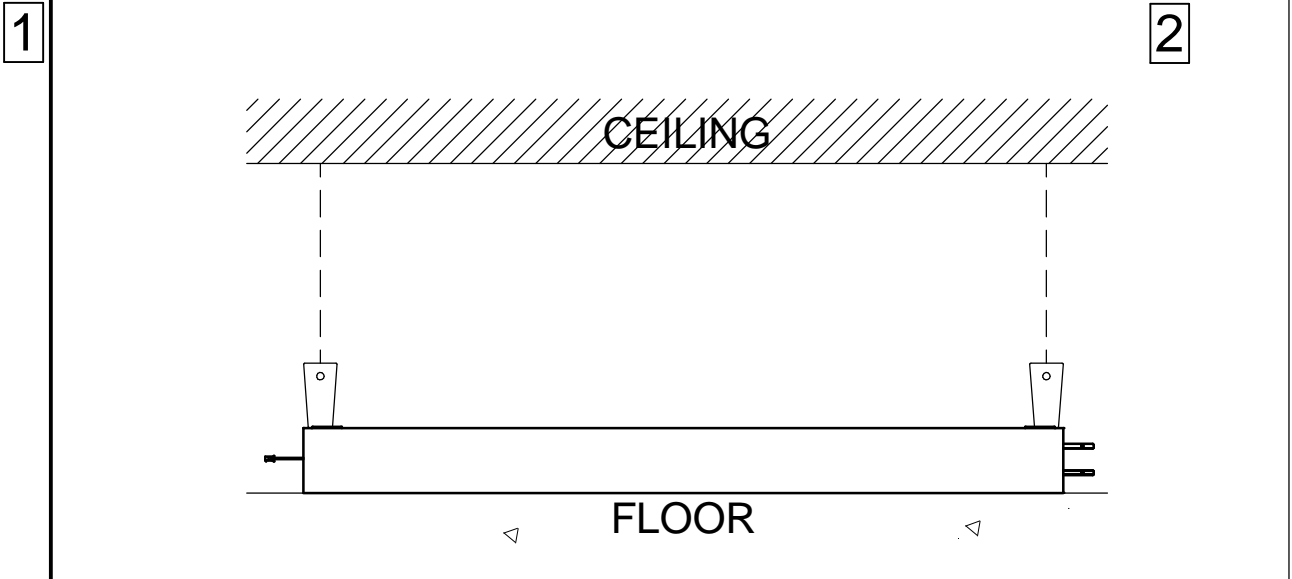
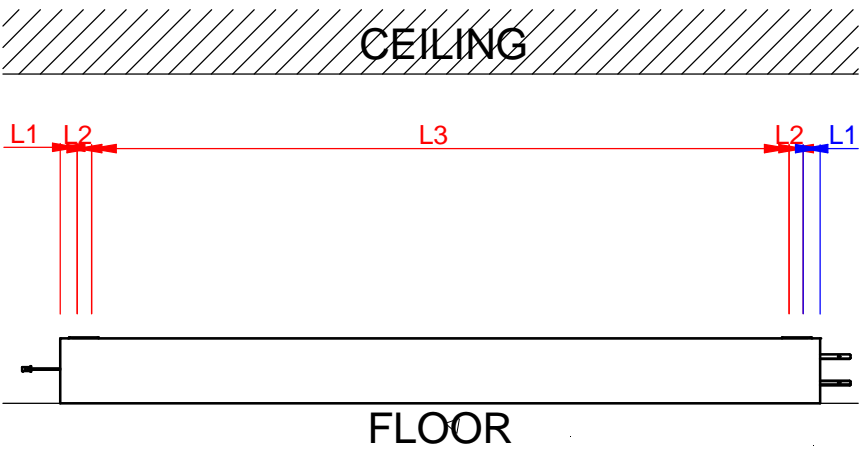
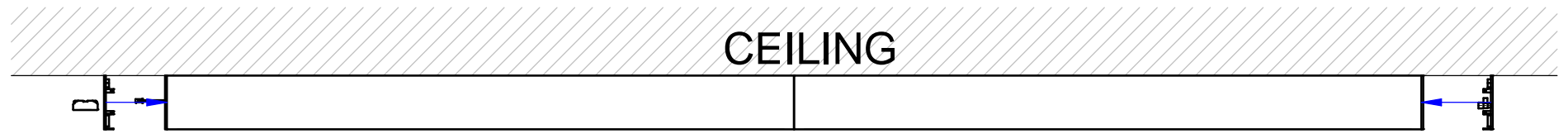
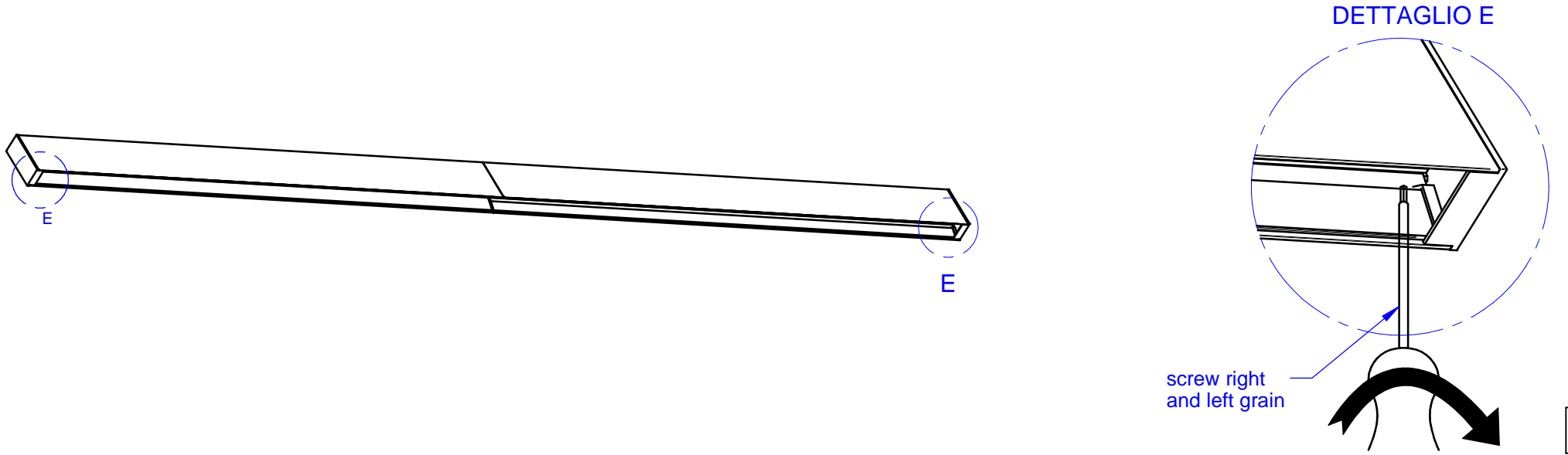

17

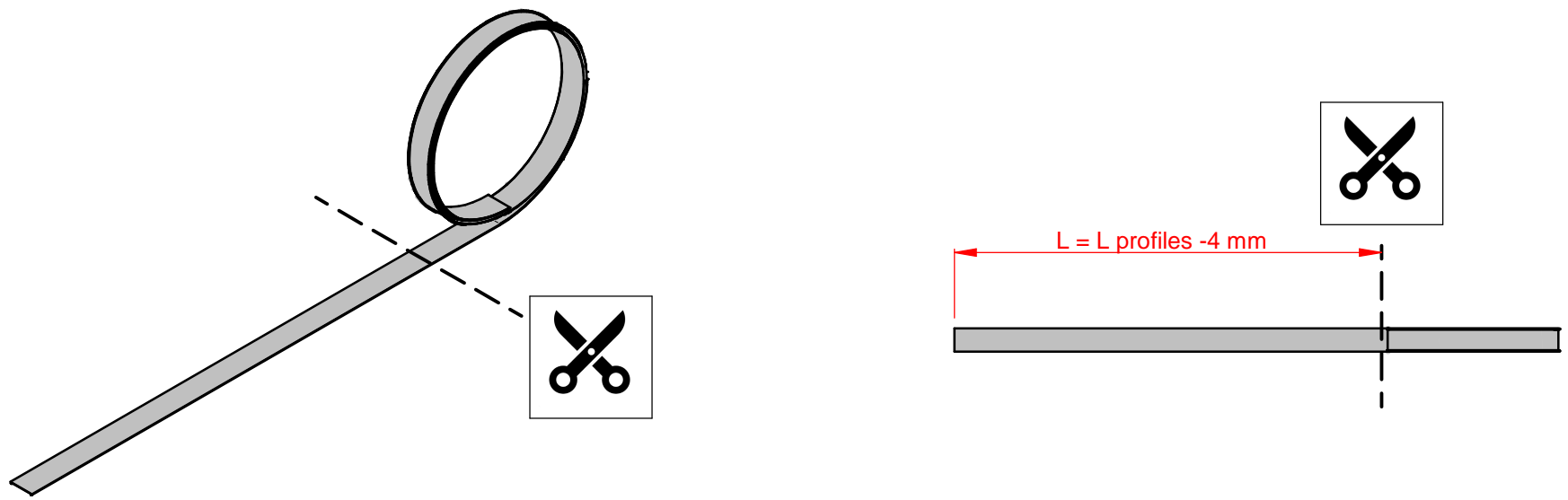

18

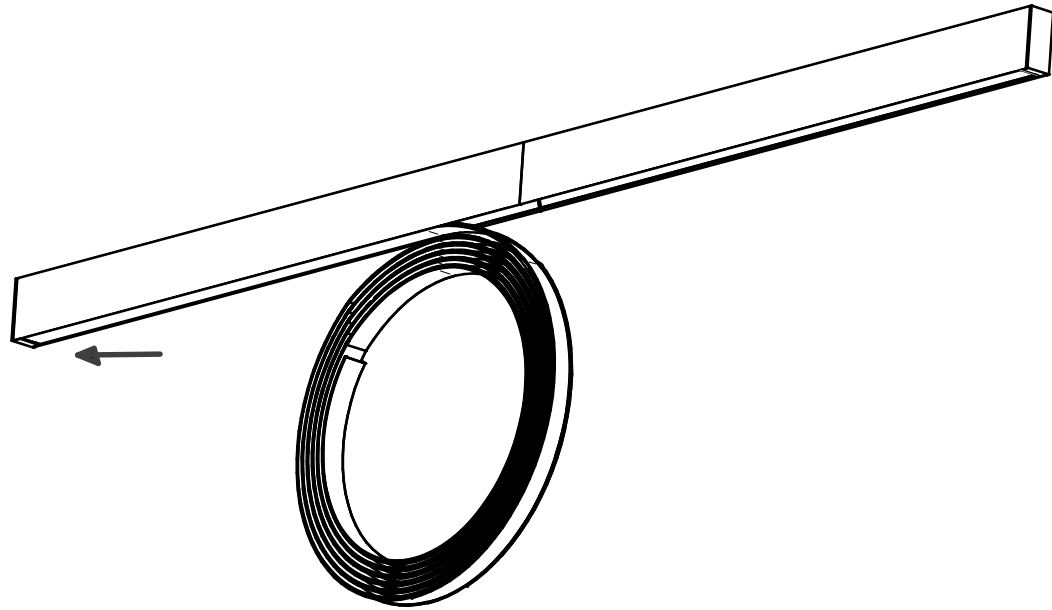

19

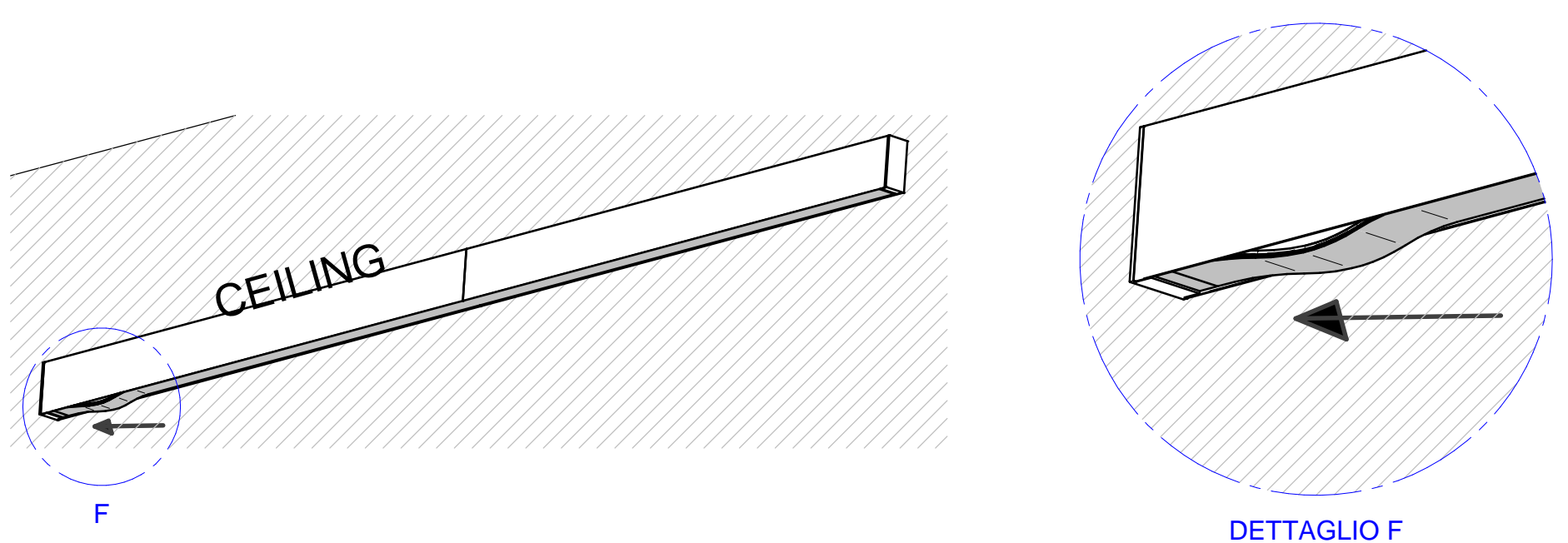

20

21 Collegare al massimo 1600 W. Poi rialimentare nuovamente la linea 220-240V. Connect up to 1600 W. Then power up 220-240V line again.

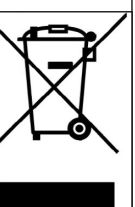

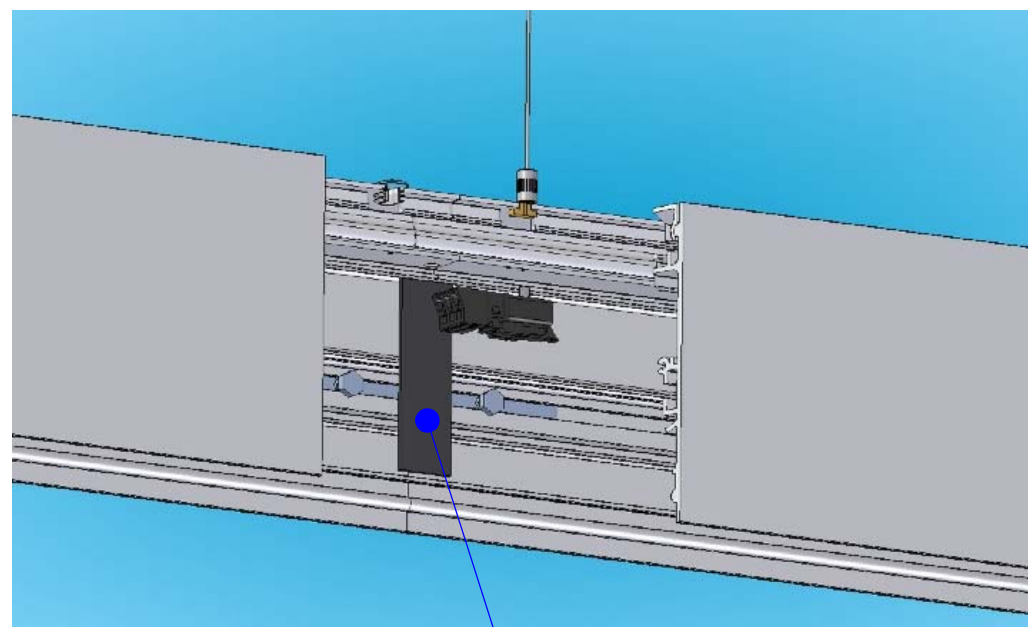
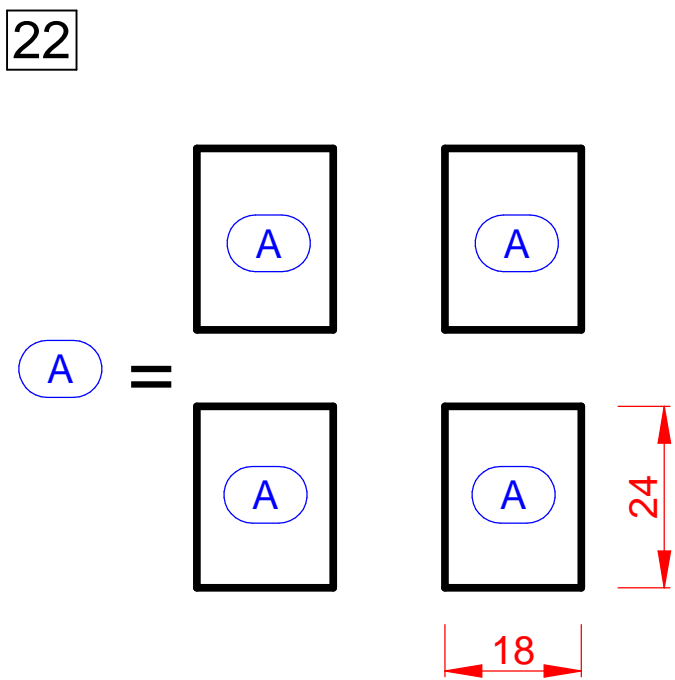
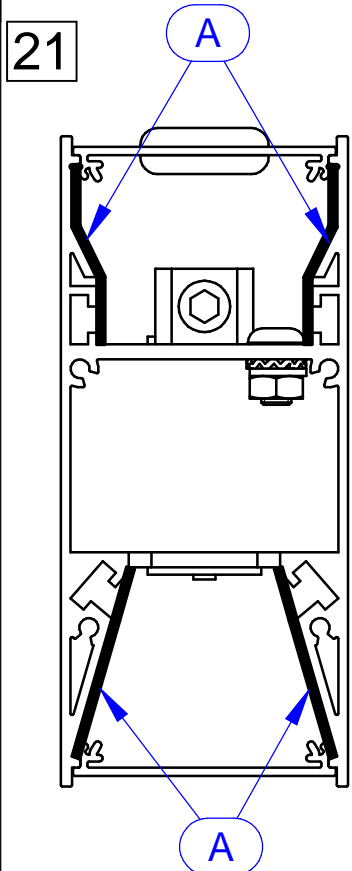

DETT.1

ITALIANO
ISTRUZIONI PER IL CORRETTO MONTAGGIO, UTILIZZO E MANUTENZIONE

ATTENZIONE: Queste istruzioni devono essere consultate e conservate dal personale specializzato nell'installazione e successiva manutenzione ordinaria e straordinaria. L'installazione e la manutenzione vanno effettuate ad apparecchio scollegato dalla rete dell'alimentazione. Tutte le operazioni devono essere effettuate da un tecnico specializzato. Modifiche o manomissioni del prodotto e il non rispetto delle indicazioni di seguito riportate annullano la garanzia possono rendere l'apparecchio pericoloso. L'apparecchio può raggiungere temperature elevate durante l'esercizio e pertanto occorre evitare il contatto con persone, animali o cose. La ditta I-lèd declina ogni responsabilità per i danni causati da un proprio prodotto montato in modo non conforme alle istruzioni.

Attenzione: Per aver un ottimo effetto visivo da una composizione accesa bisogna effettuare una mascheratura interna. Prima di effettuare l'operazione rimuovere il diffusore inferiore. Negli articoli biemissione rimuovere anche il diffusore superiore.

[21] Nelle intersezioni di giunzione bisogna mascherare utilizzando il feltrino adesivo fornito. Vengono forniti 4 feltrini adesivi e ne vengono applicati due interi per lato di emissione [22].

[DETT.1] Esempio figurato di mascheratura applicata.

ENGLISH
INSTRUCTIONS FOR CORRECT ASSEMBLY, USE AND MAINTENANCE

WARNING: This instruction sheet must be consulted and retained by the person responsible for installation and ordinary and extraordinary maintenance. Before beginning installation or maintenance operations switch off the mains supply. All these operations must be carried out by a specialised technician. Tampering or modifying the product or failing to comply with the instructions below will void the guarantee and could render the product dangerous. Given that this fixture may reach high temperatures it is important to ensure that persons, animals or other objects do not come into direct contact with it. I-lèd disclaims all responsibility for damage caused by products that have been not been assembled in compliance with the instructions.

WARNING: For the composition to have a great visual effect when switched on, it has to be internally masked. Before doing this, first remove the diffuser. For dual emission articles, you must also remove the top diffuser.

[21] Mask the joint intersections using the adhesive felt pad provided. Four adhesive felt pads are provided. Two whole ones are to be applied to the bottom part, while two pieces to be applied to the top part [22].

[DETT.1] Example of mask applied.

FRANCAIS
NOTICE DE MONTAGE, UTILISATION ET MAINTENANCE

ATTENTION: Ces instructions doivent être consultées et conservées par le personnel spécialisé dans l'installation et la maintenance successive, ordinaire et extraordinaire. L'installation et la maintenance seront effectuées avec l'appareil débranché du réseau d'alimentation. Toutes les opérations doivent être effectuées par un technicien expert. Toute modification ou détérioration du produit et le non respect des indications reportées ci-après annule la garantie et peut rendre l'appareil dangereux. L'appareil peut atteindre des températures élevées durant le fonctionnement et donc il faut éviter le contact avec personnes, animaux ou objets. La maison I-lèd décline toute responsabilité pour les dommages provoqués par un de ses produits monté de façon non conforme aux instructions.

ESPAÑOL
ISTRUCCIONES PARA UN MONTAJE, UNA UTILIZACIÓN Y UN MANTENIMIENTO CORRECTOS

ATENCIÓN: el personal especializado en la instalación y en el posterior mantenimiento ordinario y extraordinario ha de consultar y guardar estas instrucciones. La instalación y el mantenimiento han de realizarse con el equipo desconectado de la corriente. Un técnico especializado deberá realizar todas las operaciones. El equipo puede ser peligroso y la garantía queda anulada en caso de modificaciones o alteraciones de éste y cuando se incumplen las indicaciones facilitadas a continuación. El equipo puede alcanzar temperaturas elevadas durante el funcionamiento y, por consiguiente, se ha de evitar el contacto con personas, animales o cosas. La empresa I-lèd queda eximida de toda responsabilidad por los daños causados por uno de sus productos no montado en cumplimiento de las instrucciones.

DEUTSCH
ANWEISUNGEN FÜR DIE KORREKTE MONTAGE, GEBRAUCH UND WARTUNG

ACHTUNG: Diese Anweisungen müssen von qualifizierten Elektrikern gelesen und aufbewahrt werden, die für die Installation und die anschließende ordentliche und außerordentliche Wartung zuständig sind. Die Installation und Wartung der Leuchte darf nur dann durchgeführt werden, wenn die Leuchte vom Stromnetz getrennt ist. Alle Eingriffe dürfen nur von einem qualifizierten Elektriker durchgeführt werden. Die Durchführung von Änderungen am Produkt und die Nichtbeachtung der unten stehenden Anweisungen führen zu einem sofortigen Verfall vom Garantieanspruch und beeinträchtigen die Gerätesicherheit! Die Leuchte kann sehr heiß werden, wenn sie eingeschaltet ist. Den Kontakt mit Personen, Tieren und Gegenständen vermeiden. Die Firma I-lèd übernimmt keine Haftung für Schäden, die durch ein Produkt verursacht worden sind, bei dessen Montage die Anweisungen nicht beachtet worden sind.

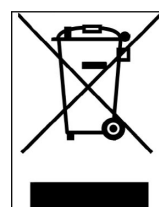

I	GB	F	D	E
<p>Procedura di cablaggio</p> <p>1 Chiudere l' interruttore generale OFF</p> <p>2 Collegare i faretto all' alimentatore</p> <p>3 Collegare l' alimentatore alla rete</p> <p>4 Aprire l' interruttore generale ON</p> <p>N.B</p> <p>Tutte le operazioni di manutenzione ed installazione vanno eseguite con l' interruttore generale in posizione OFF</p> <p>Non collegare più faretto in parallelo all' uscita dello stesso alimentatore</p> <p>I faretto necessitano di corrente costante stabilizzata</p> <p>Per il N° di led collegabili all' alimentatore seguire le indicazioni sull'etichetta dello stesso</p> <p>IL FARETTO RISULTA GARANTITO SOLO CON ALIMENTATORI DISTRIBUITI DA i-LèD</p>	<p>Wiring procedure</p> <p>1 Switch off the main switch OFF</p> <p>2 Connect the spotlights to the power supply unit.</p> <p>3 Connect the power supply unit to the network</p> <p>4 Switch on the main switch ON</p> <p>N.B</p> <p>All the maintenance and installation procedures must be carried out with the main switch in position OFF</p> <p>Do not connect too many parallel spotlights to the output of the same power supply unit</p> <p>Use stabilized constant current for the spotlights</p> <p>Follow the instructions on the label of the power supply unit for the number of spotlights that can be connected to it</p> <p>SPOTLIGHTS ARE GUARANTEED ONLY IF POWER SUPPLY UNITS DISTRIBUTED BY i-LèD ARE USED</p>	<p>Procédure de câblage</p> <p>1 Couper le disjoncteur OFF</p> <p>2 Relier les spots au driver</p> <p>3 Relier le driver au réseau</p> <p>4 Connecter le disjoncteur ON</p> <p>N.B.</p> <p>Toutes les opérations de maintenance et d'installation seront effectuées avec le disjoncteur sur la position OFF</p> <p>Ne pas relier plusieurs spots en parallèle sur la sortie du même driver</p> <p>Les spots nécessitent d'un courant constant stabilisé</p> <p>Pour le N° de leds reliables au driver, suivre les indications reportées sur son étiquette</p> <p>LE SPOT EST GARANTI SEULEMENT AVEC LES DRIVERS DISTRIBUES PAR i-LèD</p>	<p>Anleitung zur Verkabelung</p> <p>1 Schalten Sie den Hauptschalter aus OFF</p> <p>2 Schliessen Sie die Strahler an dem Stromversorgungsgeraet an</p> <p>3 Schliessen Sie das Stromversorgungsgeraet ans Netz an</p> <p>4 Schalten Sie den Hauptschalter ein ON</p> <p>N.B</p> <p>Die Wartungs - und Instandhaltungsvorgänge müssen mit Hauptschalter in Position durchgeführt werden OFF</p> <p>Schalten Sie weiterhin keinen Strahler mehr parallel am Ausgang desselben Stromversorgungsgeräts</p> <p>Die Strahler brauchen Konstantstrom</p> <p>Beachten Sie die Etikette des Stromversorgungsgeräts, um die Anzahl der am Stromversorgungsgerät anzuschliessenden LED zu erfahren.</p> <p>DIE GARANTIE IST GÜLTIG NUR FÜR STRAHLER, DIE MIT i-LèD STROMVERSORGUNGSGERÄTEN EINGESPEIST WERDEN.</p>	<p>Procedimiento de cableado</p> <p>1 Cerrar el interruptor general OFF</p> <p>2 Conectar los focos al alimentador</p> <p>3 Conectar el alimentador a la red</p> <p>4 Abrir el interruptor general ON</p> <p>N.B</p> <p>Todas las operaciones de mantenimiento e instalación se tendrán que llevar a cabo con el interruptor general en posición OFF</p> <p>No conectar má focos en paralelo a la salida del mismo alimentador</p> <p>Los focos necesitan corriente constante estabilizada</p> <p>Sobre el N° de leds conectables al alimentador seguir las indicaciones indicadas en la etiqueta del mismo</p> <p>EL FOCO SÓLO ESTÁ GARANTIZADO CON ALIMENTADORES DISTRIBUIDOS POR i-LèD</p>

ON-OFF / BLUETOOTH

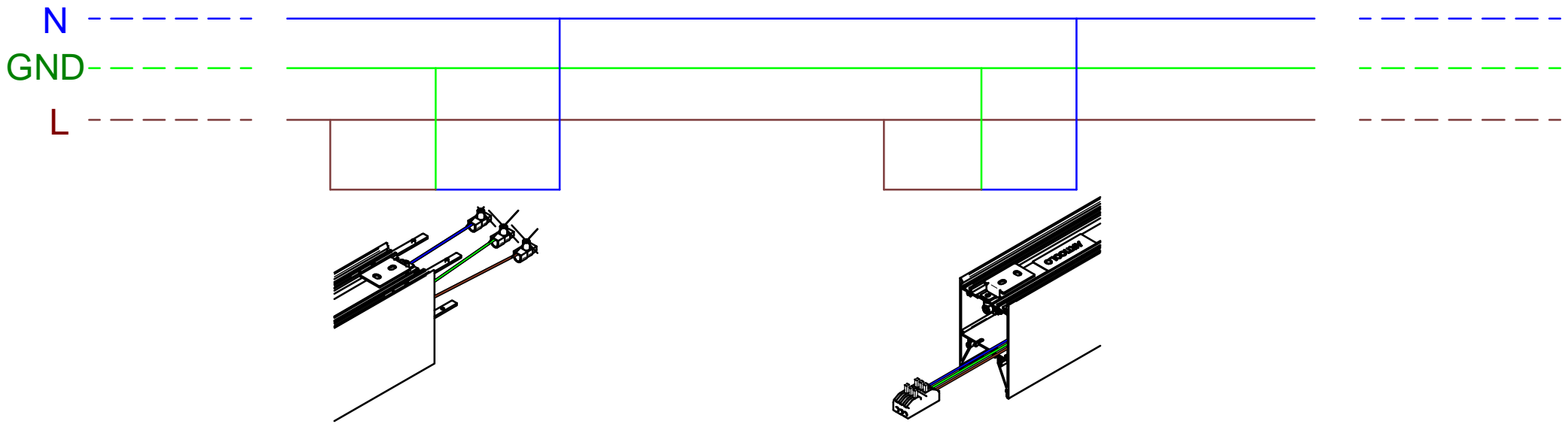

DALI

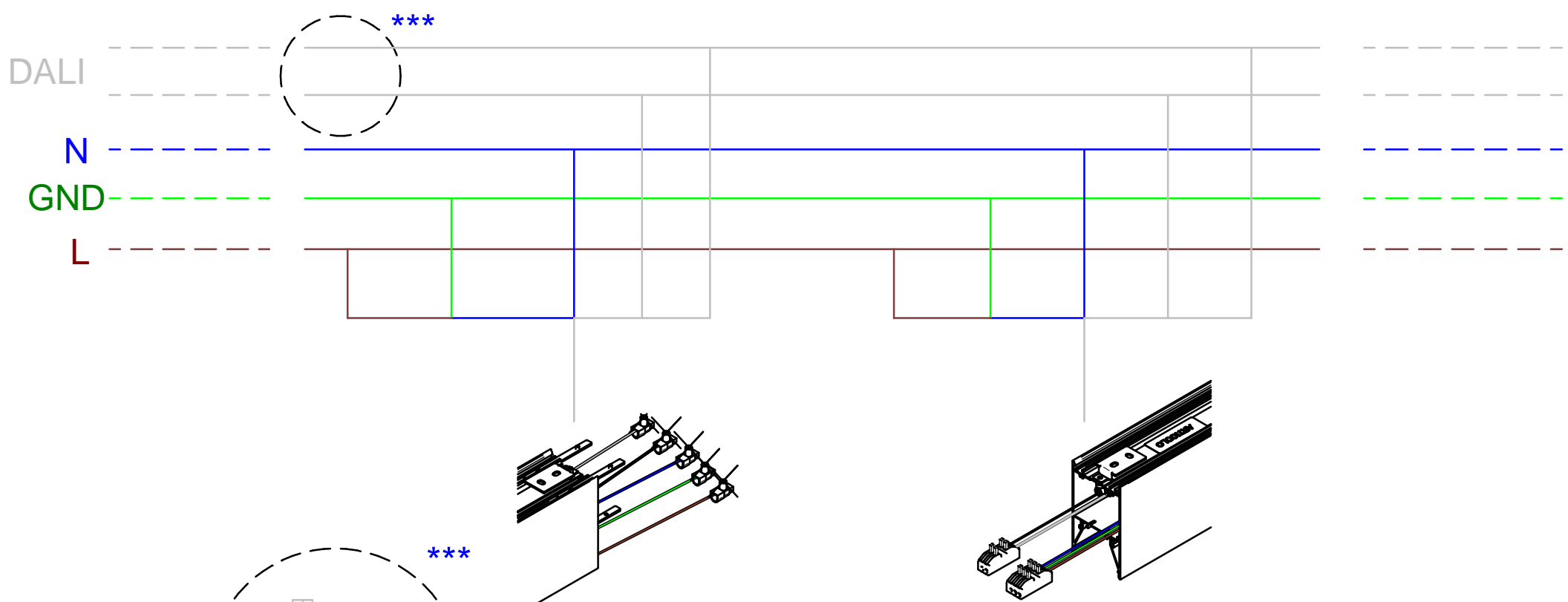

PUSH

