

# Floor standing enclosures

## Combinable and compact version, high protection IP66

### MOUNTING INSTRUCTIONS

7697-0302-01 REV. 8

---



# MCS-HP

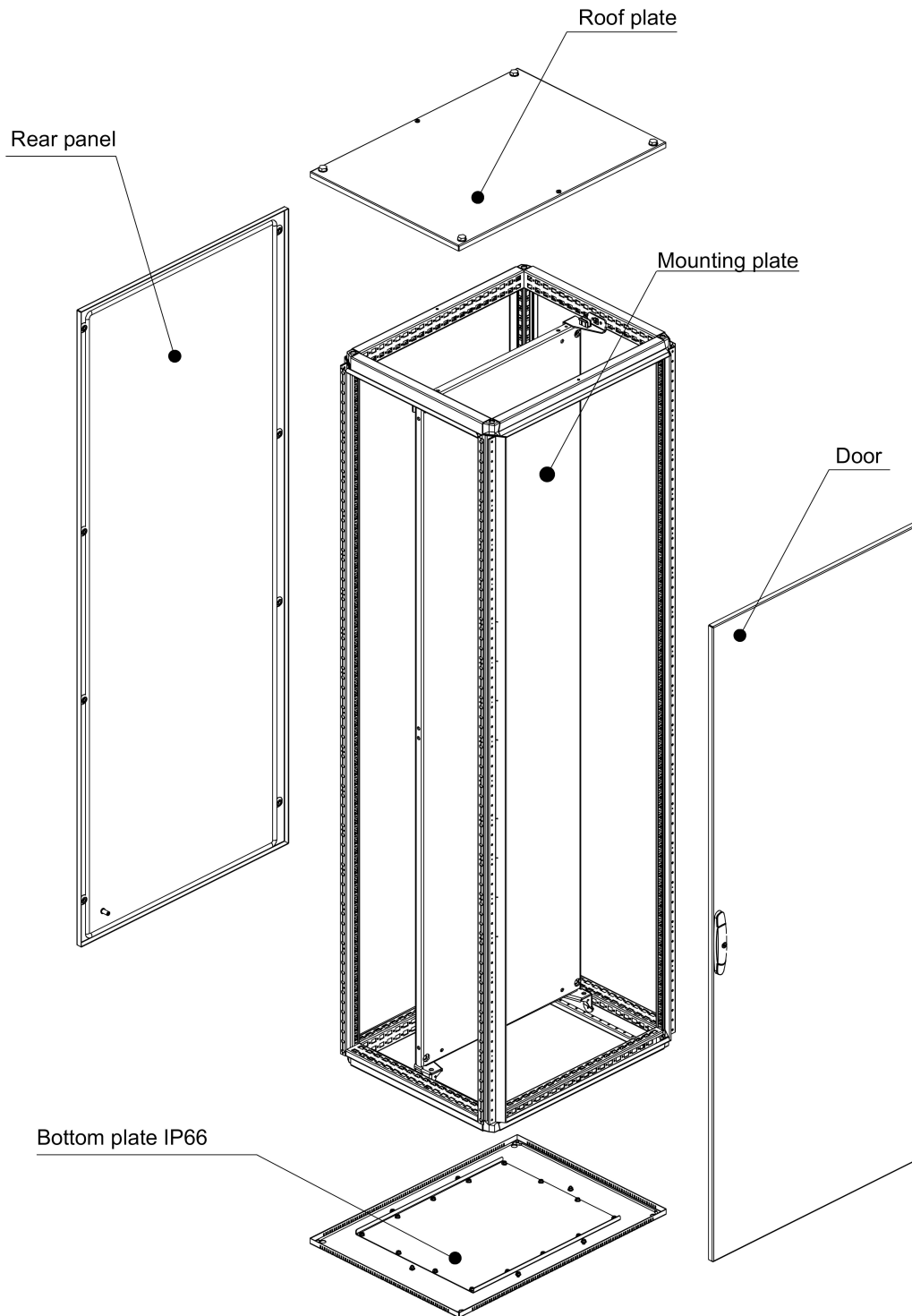

# MKS-HP

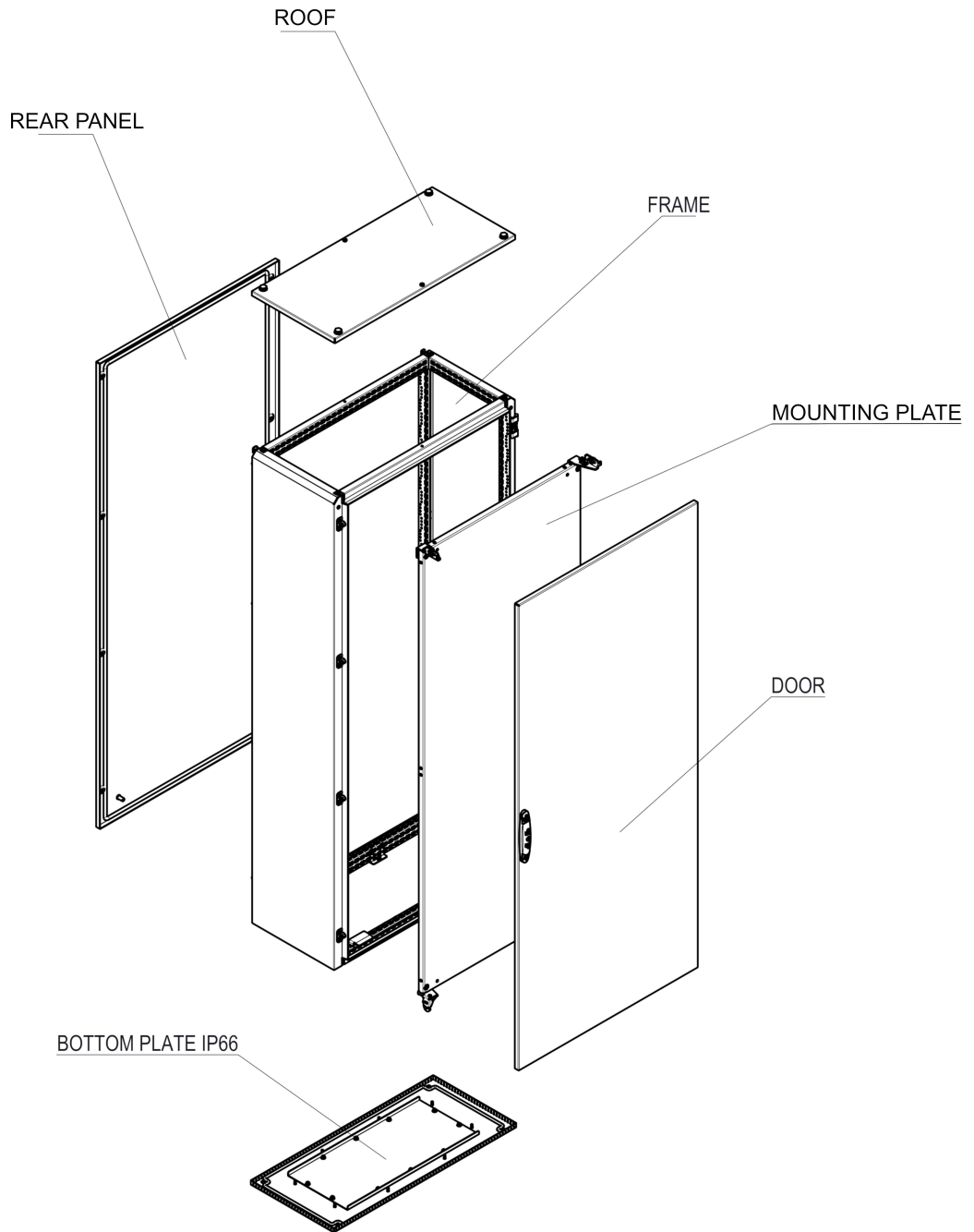

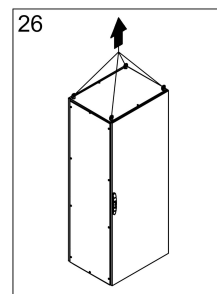
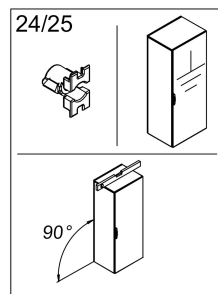
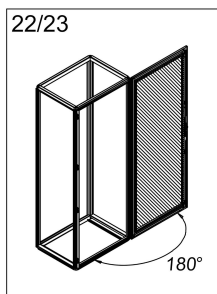
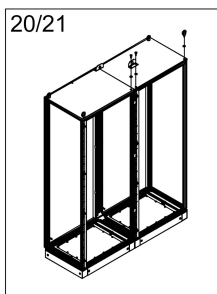
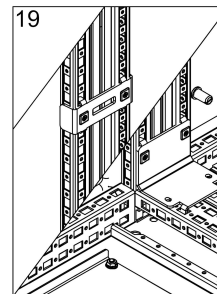
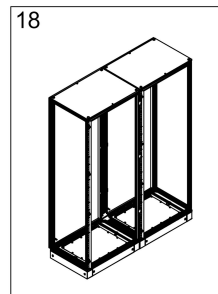
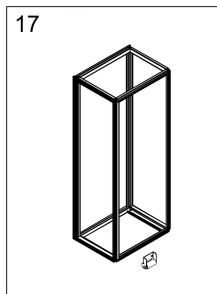
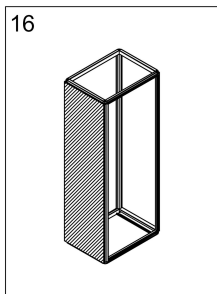
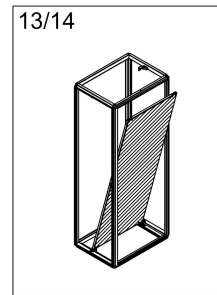
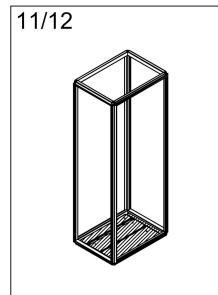
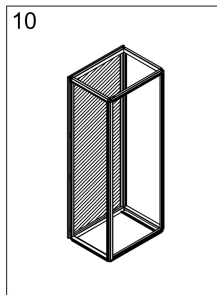
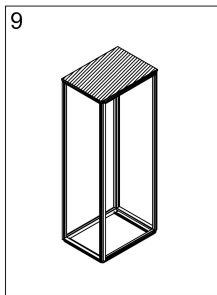
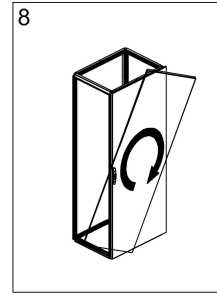
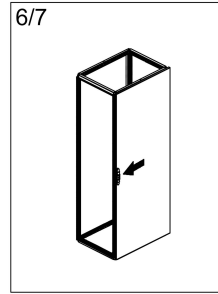
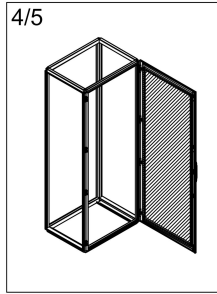
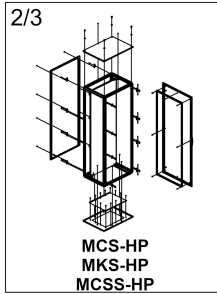

**WARNING:** When mounting on or over a combustible surface, a floor plate of at least 1.43 mm galvanized or 1.6 mm uncoated steel extended at least 150 mm beyond the equipment on all sides must be installed.

**WARNING:** In order to maintain the environmental integrity of the enclosure, devices with the same environmental ratings shall be used to close openings in customized enclosure.

# MCS-HP

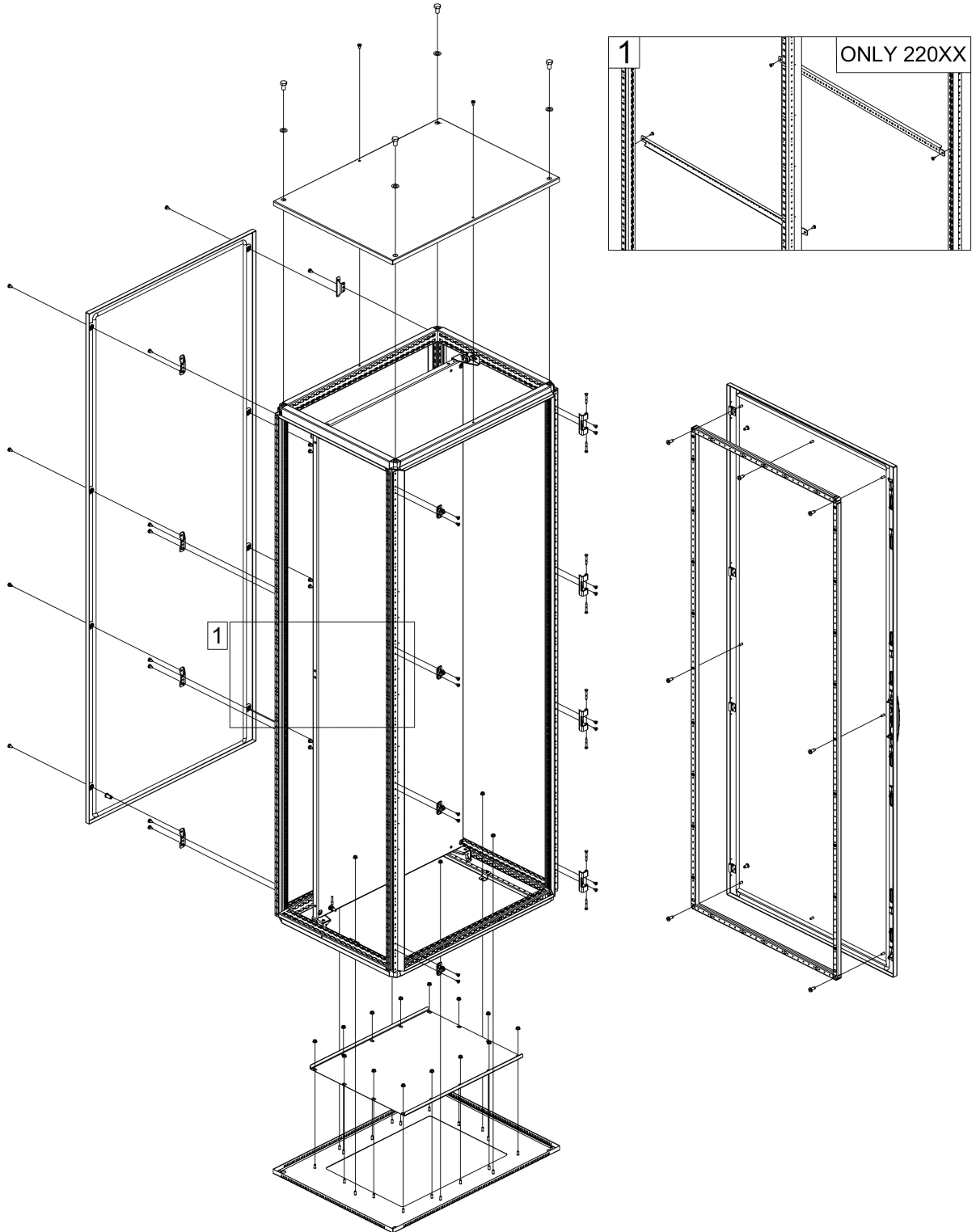

# MKS-HP

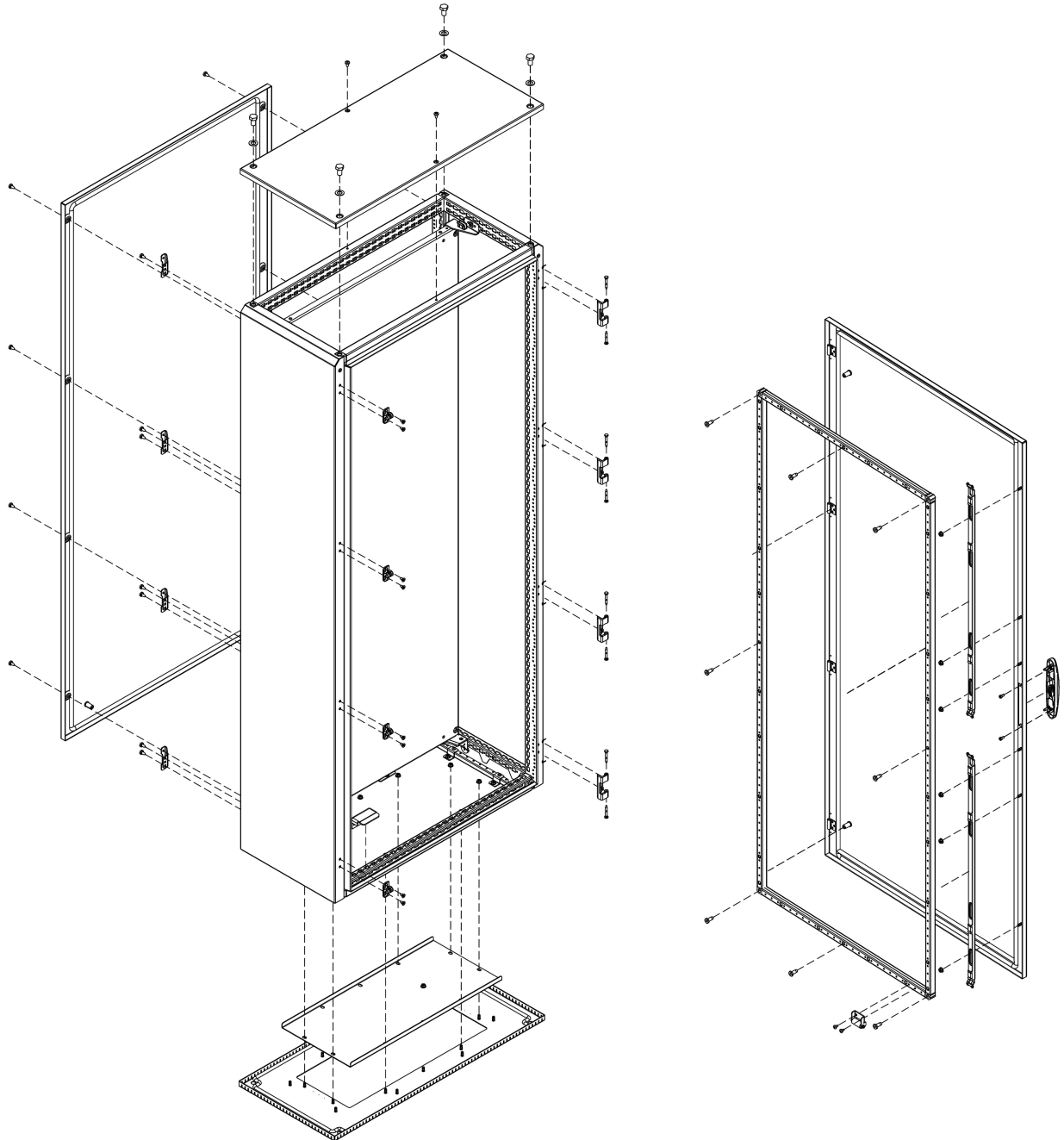

# MCSS-HP

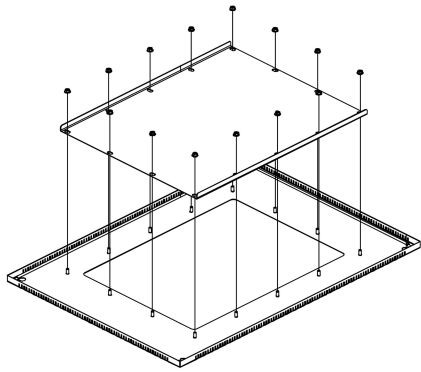
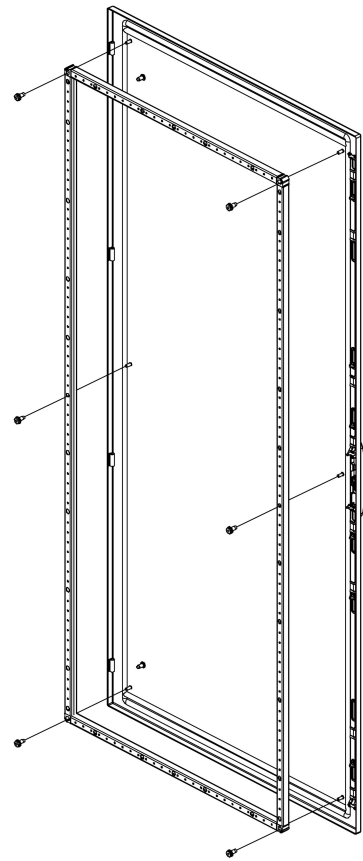
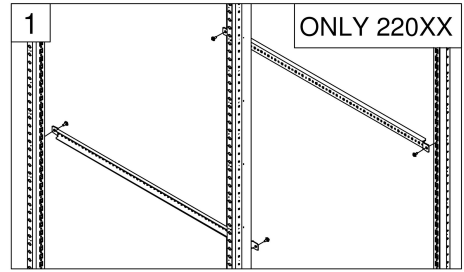
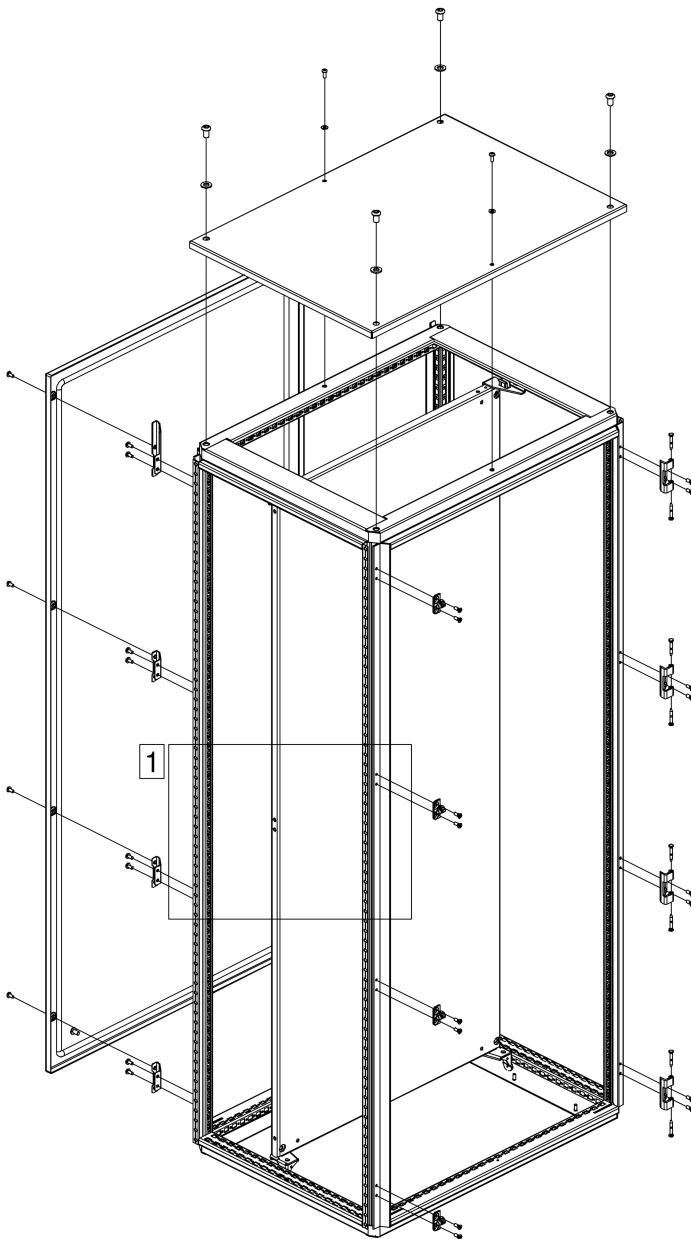

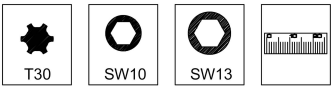

# COMBINABLE ENCLOSURE

H	A	A'	B	B'
1100	275	175	425	525
1400	325	325	525	525
1600	425	425	525	525
1800	525	525	525	525
2000	625	625	525	525
2200	625	725	725	525

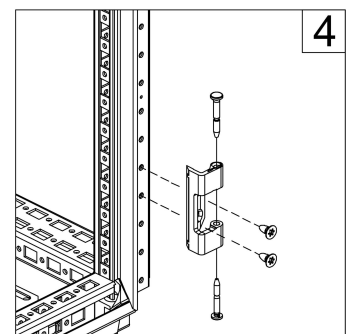
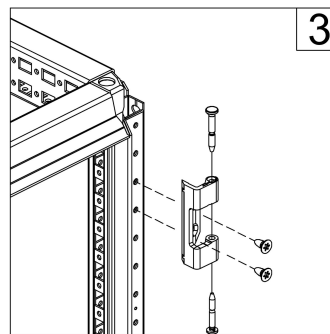
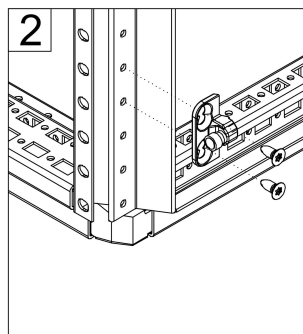
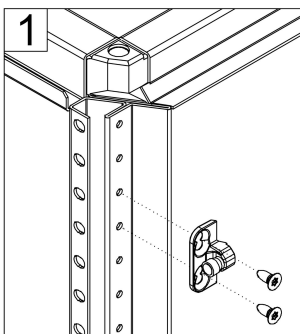
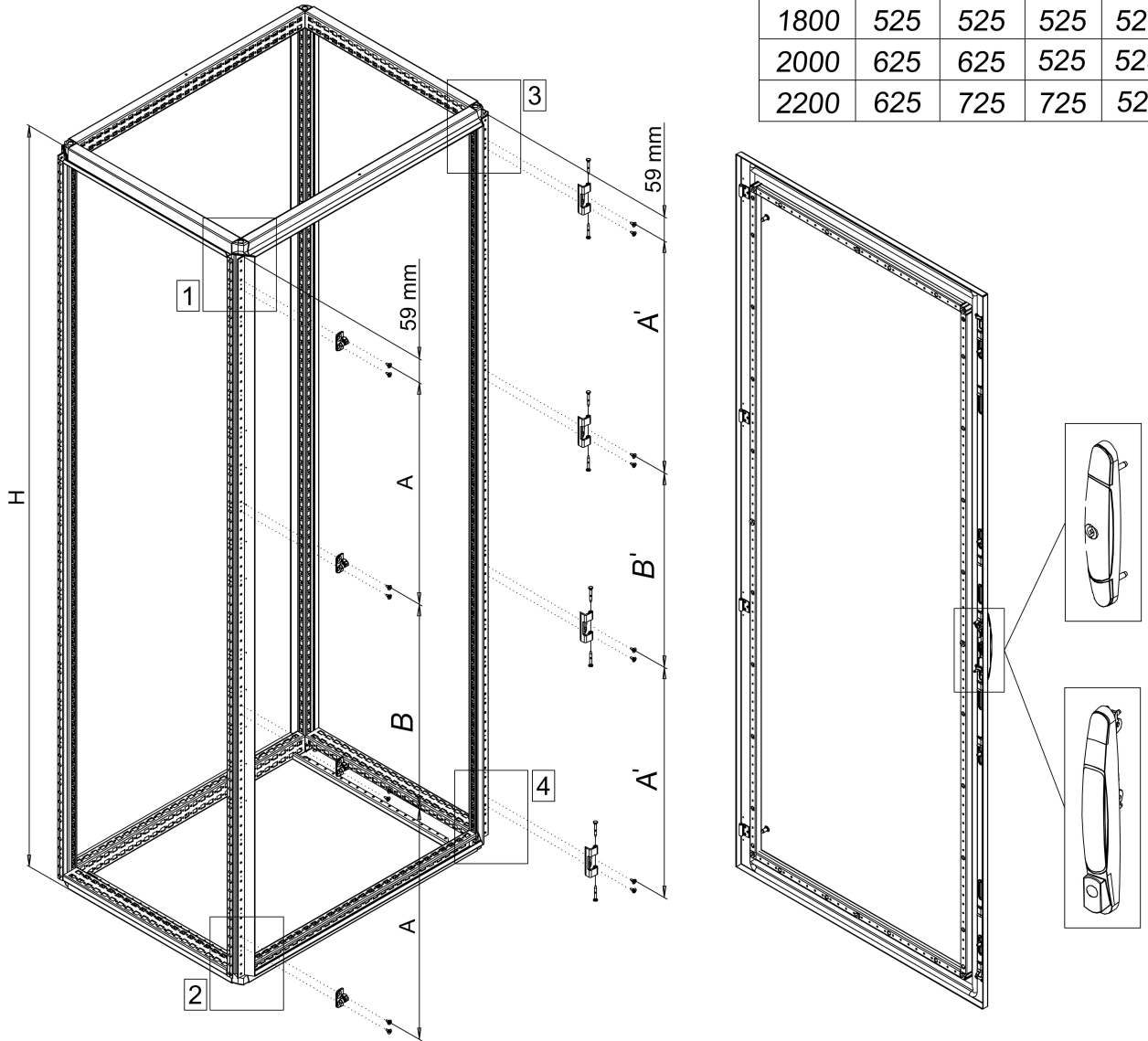



Ref.	Pic.	Qty.
A		2
B		4

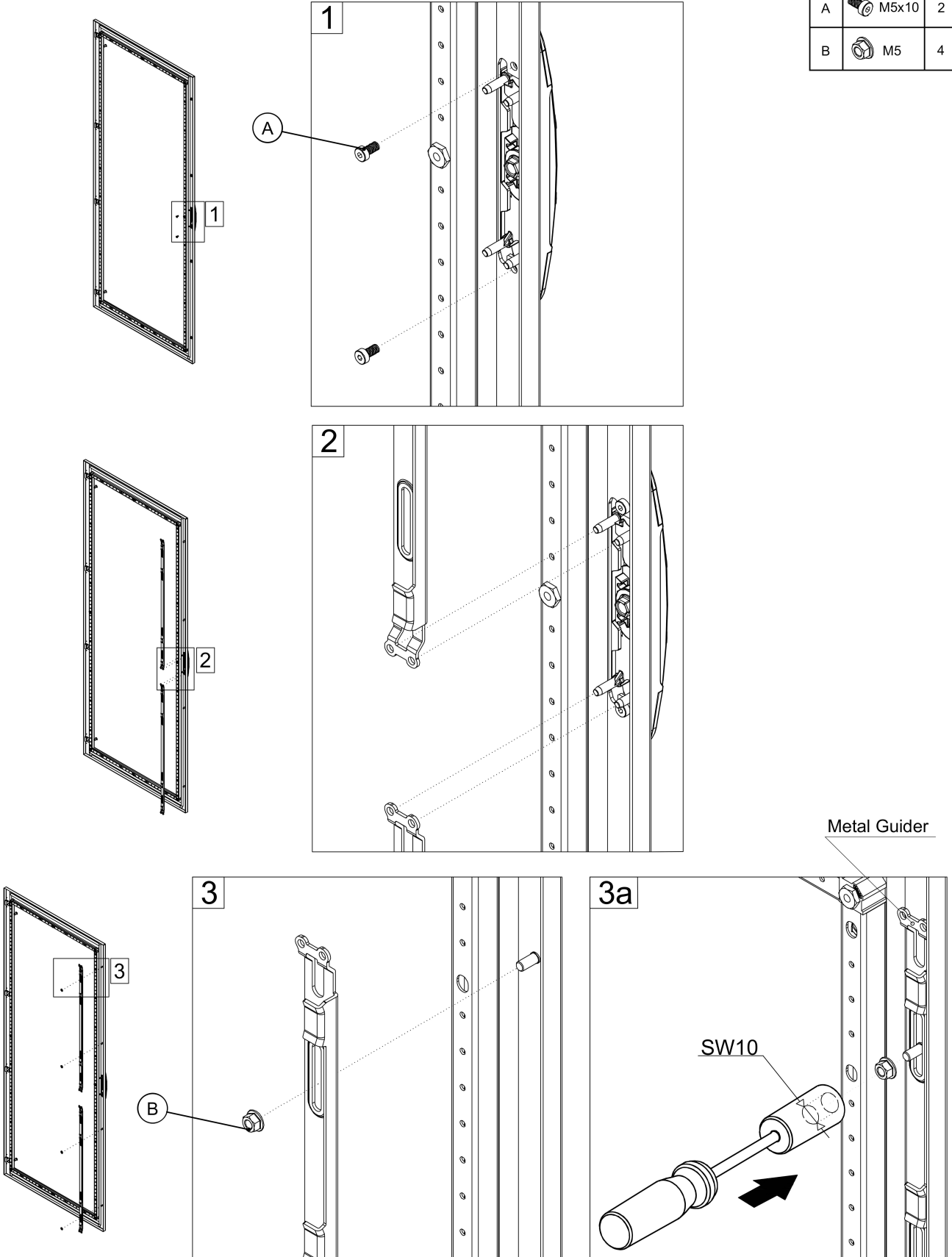



# MOUNTING THE LIFT HANDLE

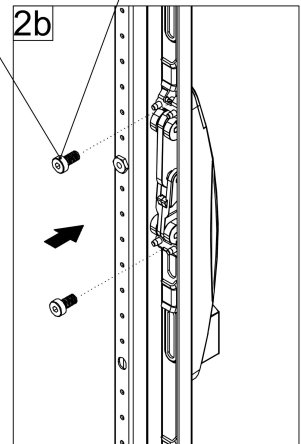
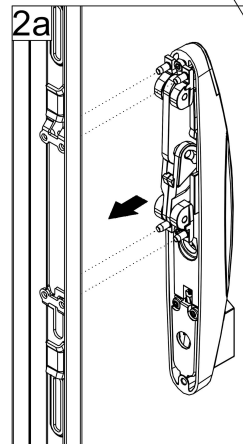
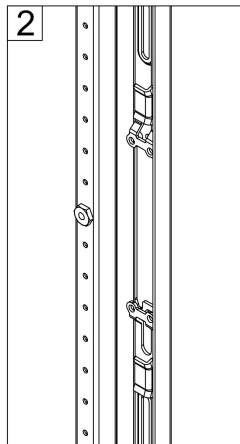
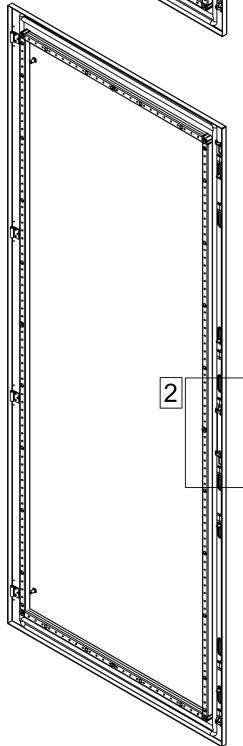
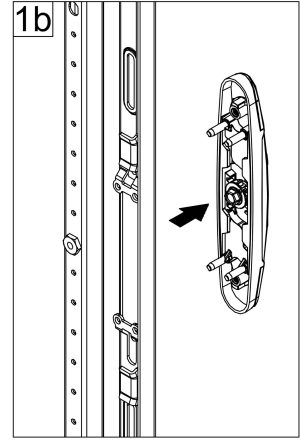
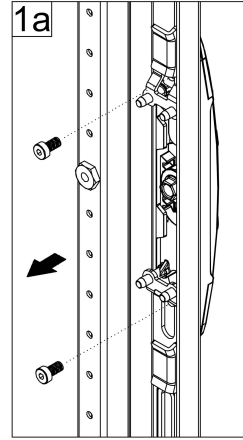
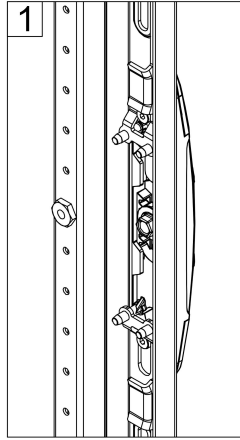
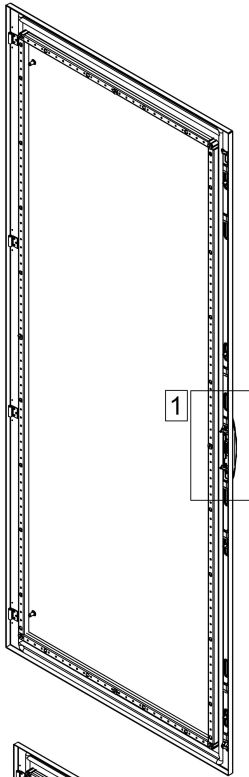

Torque  
4-5.5 Nm

A



Standard Locking System

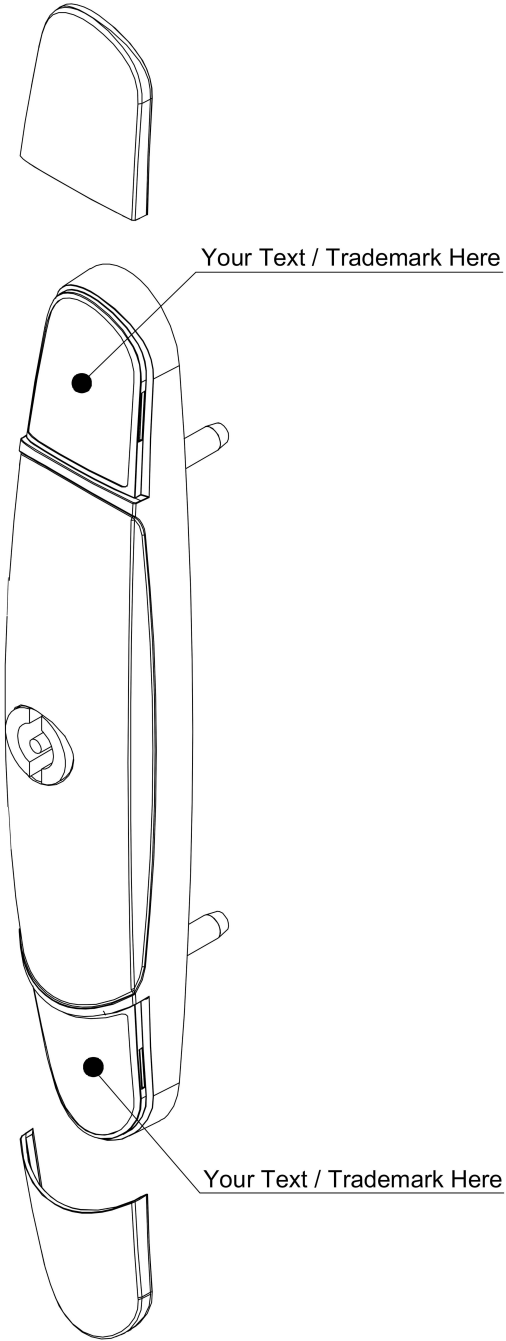

Lift Handle Locking System

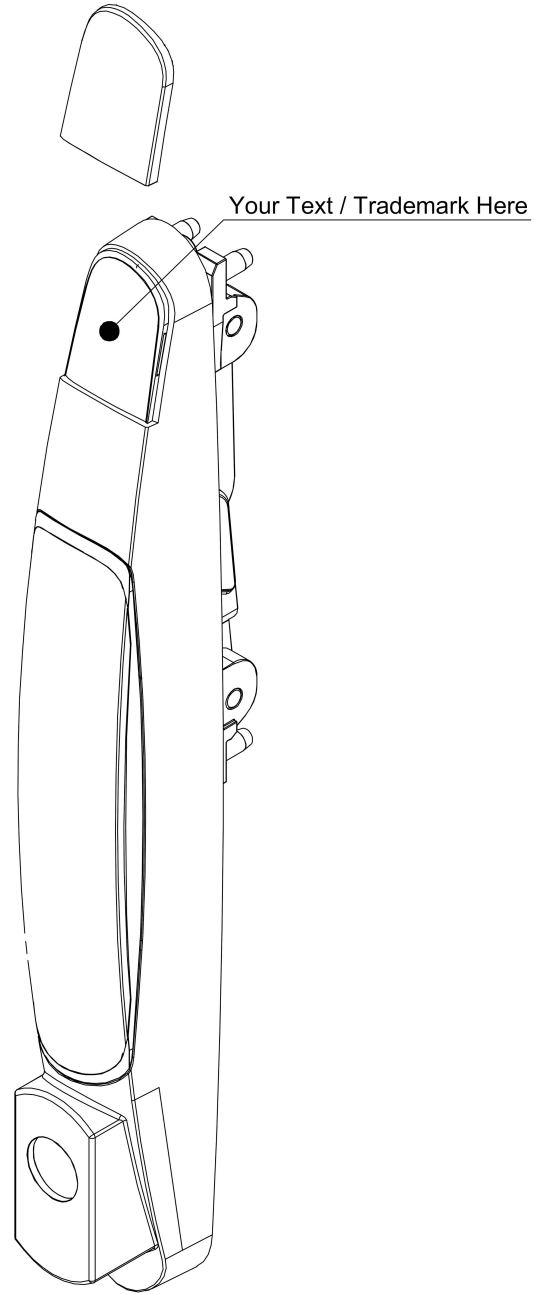

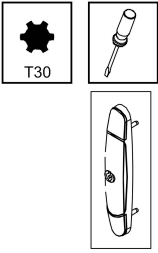

Standard Locking System

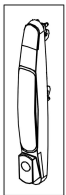
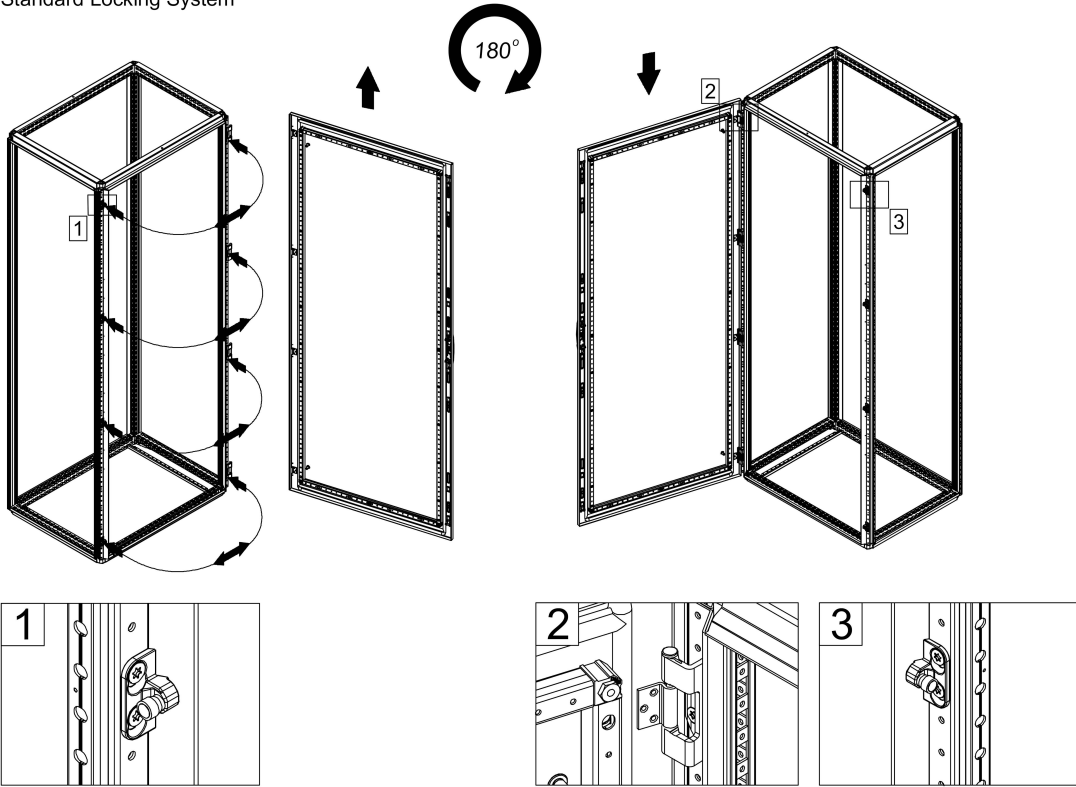

Lift Handle Locking System

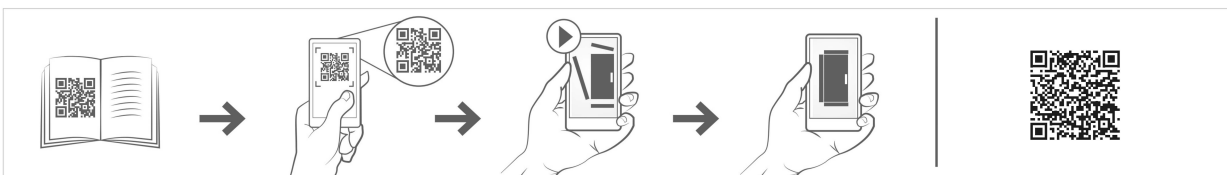
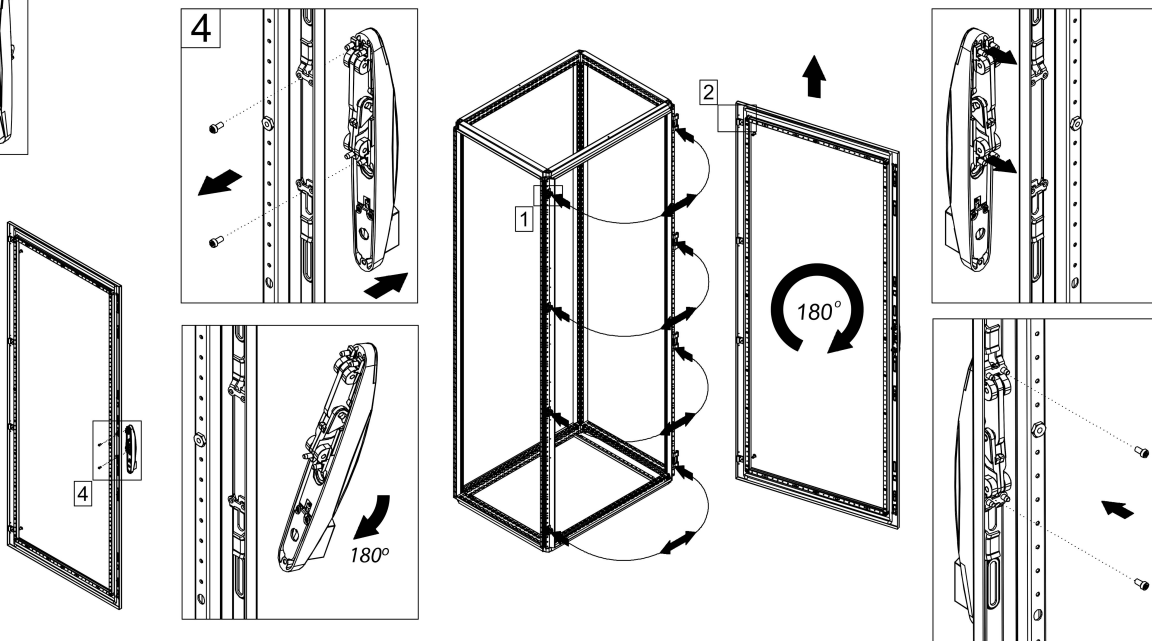

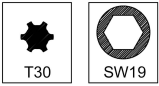

# ROOF PLATE

Ref.	Pic.	Qty.
A		2
B		4
C		4

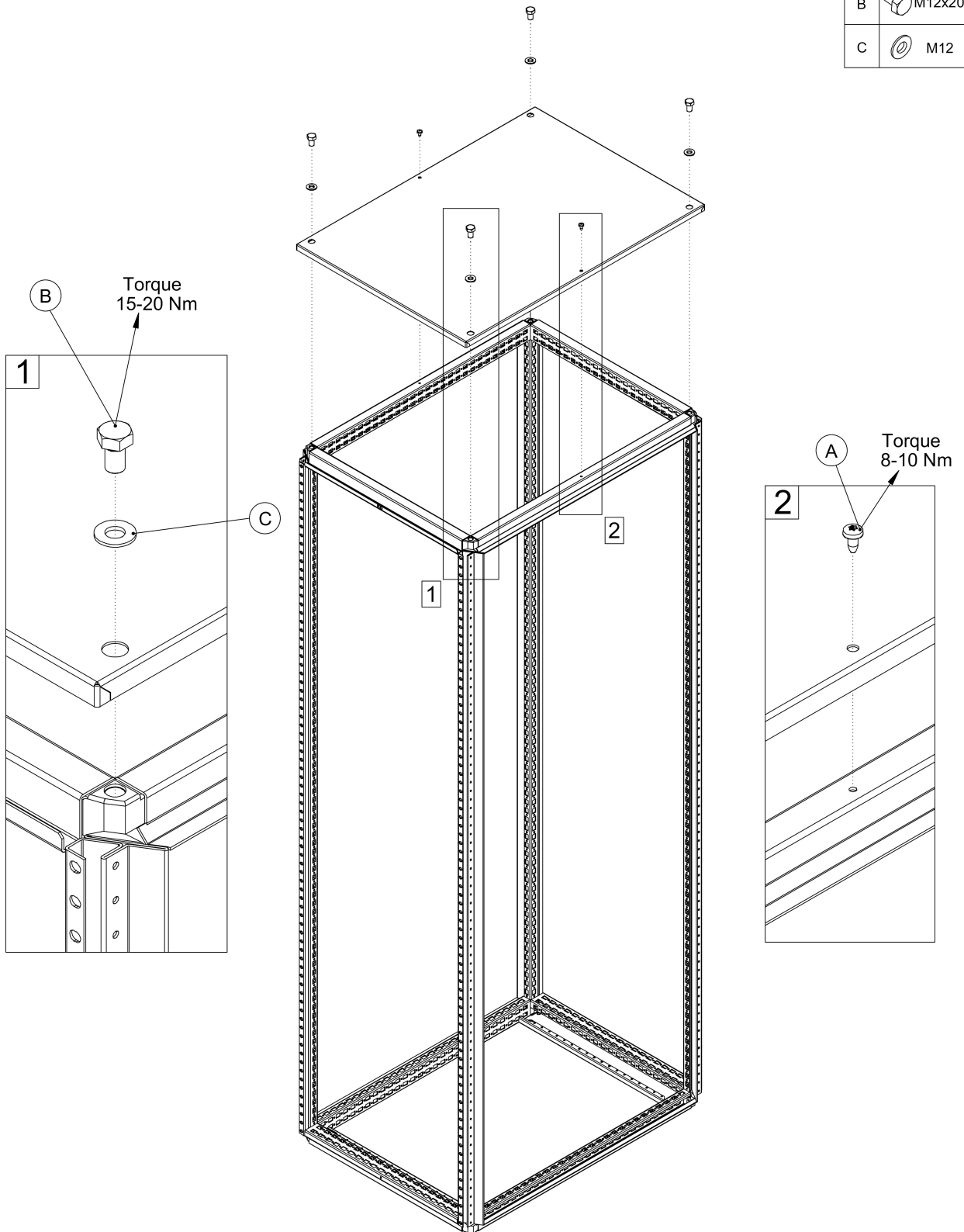



# BACK PANEL

Ref.	Pic.	Qty.
A		22

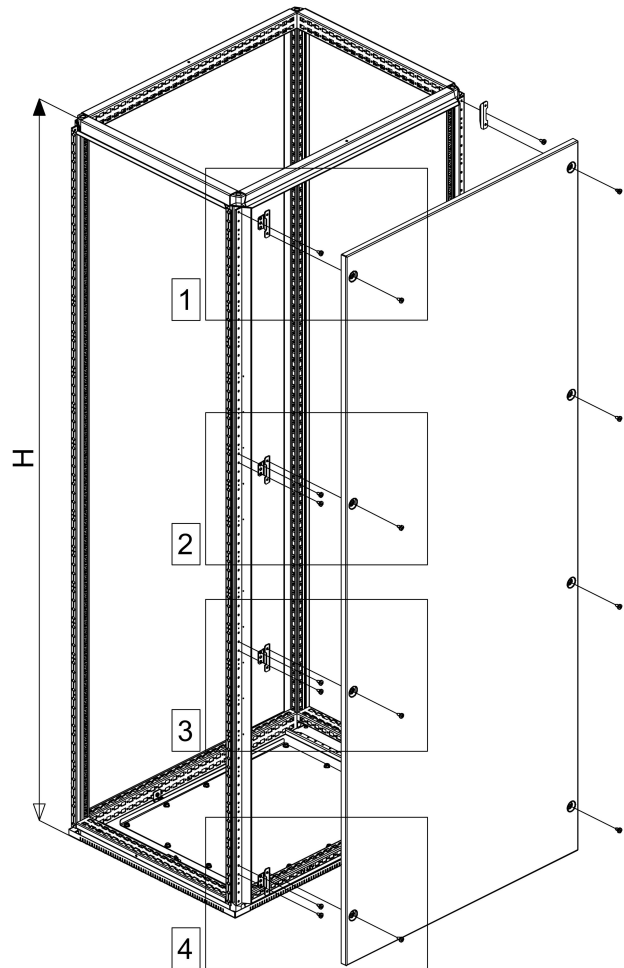
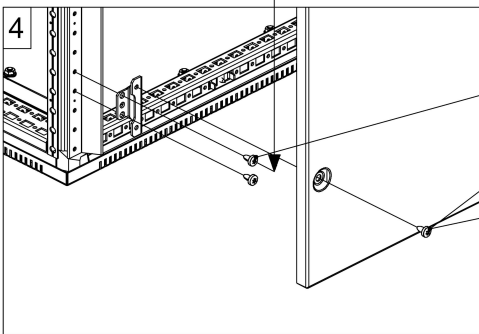
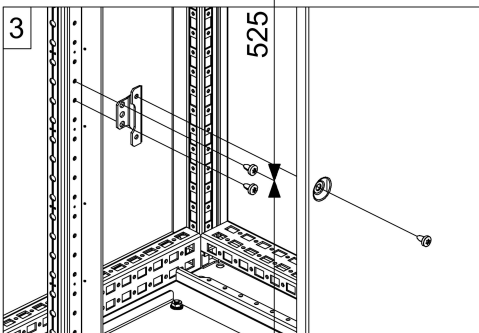
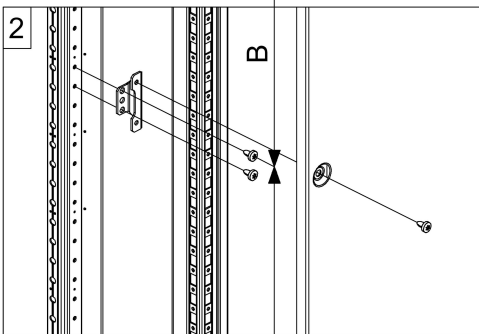
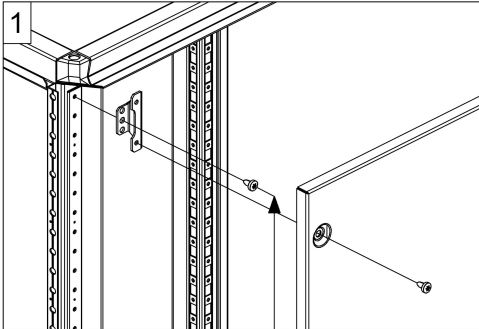

H	A	B
1100	-	350
1400	325	375
1600	425	475
1800	525	575
2000	625	675
2200	725	775



# BOTTOM PLATE MCS-HP

Ref.	Pic.	Qty.
A		6
B		20
C		2
D		4

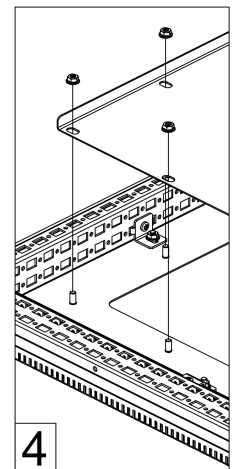
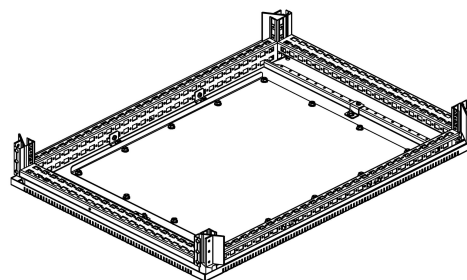
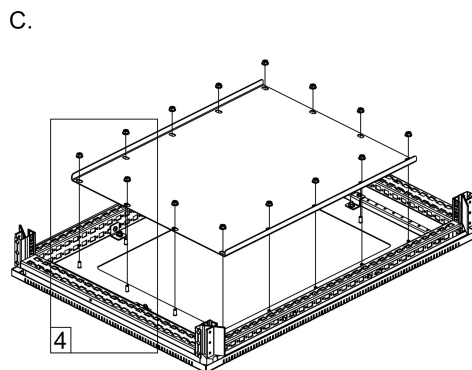
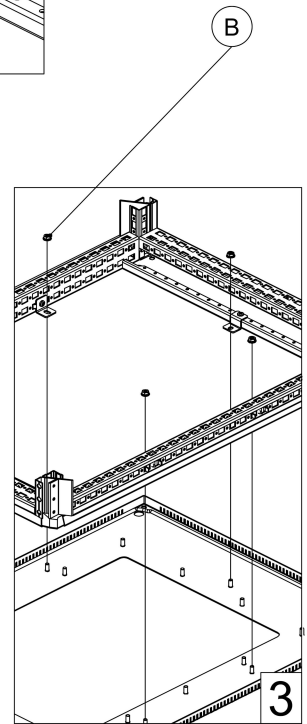
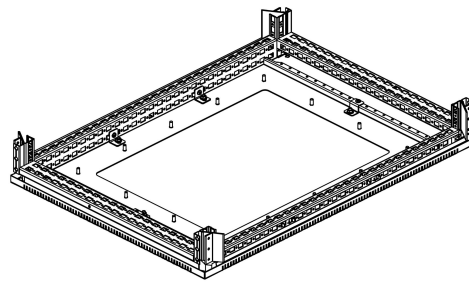
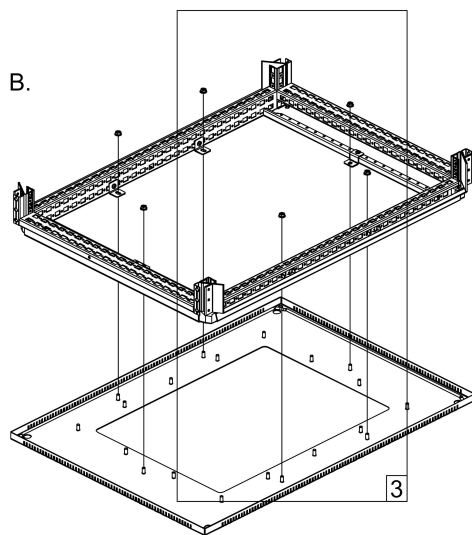
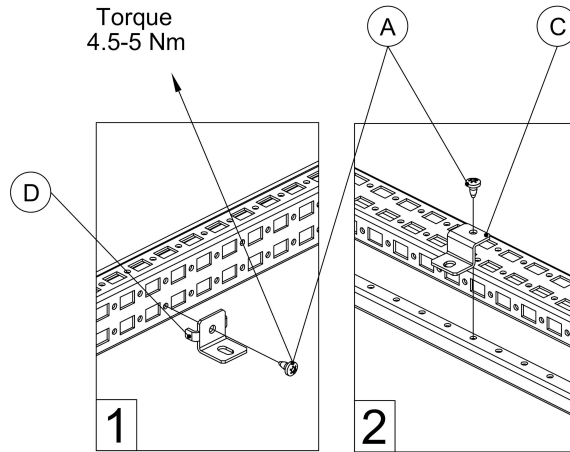
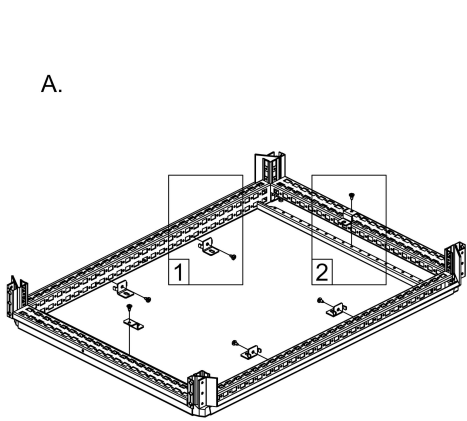



# BOTTOM PLATE MKS-HP

Ref.	Pic.	Qty.
A		12
B		22
C		4
D		4

A.

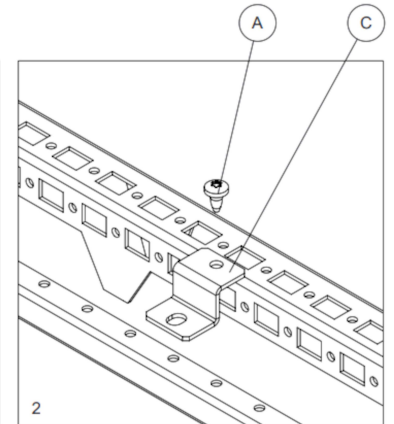
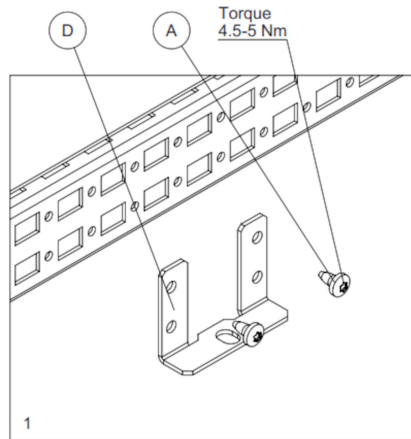
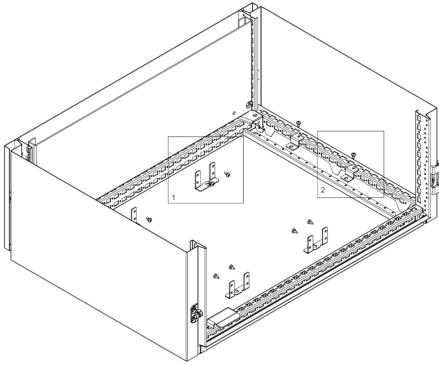

B.

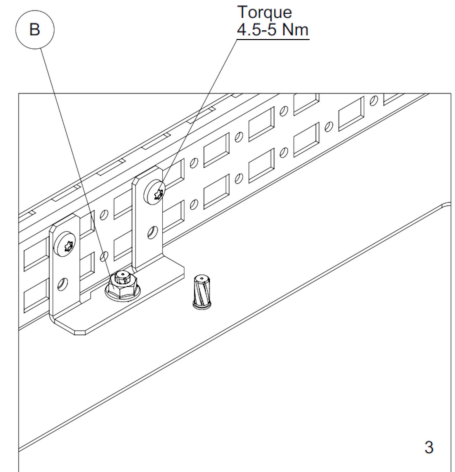
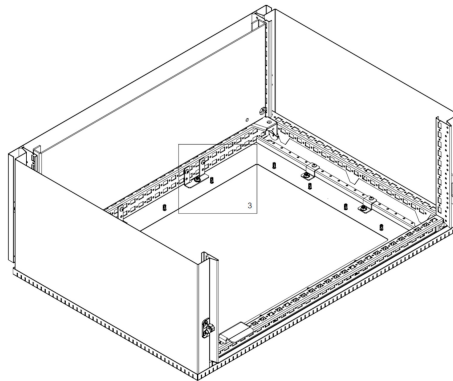
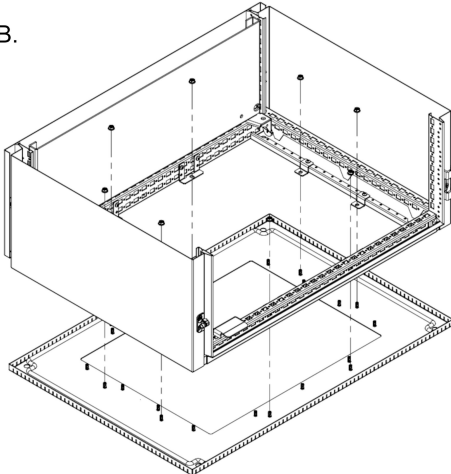

C.

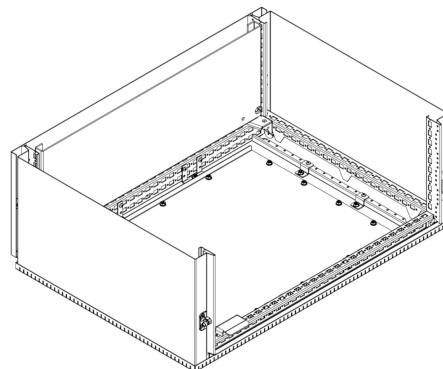
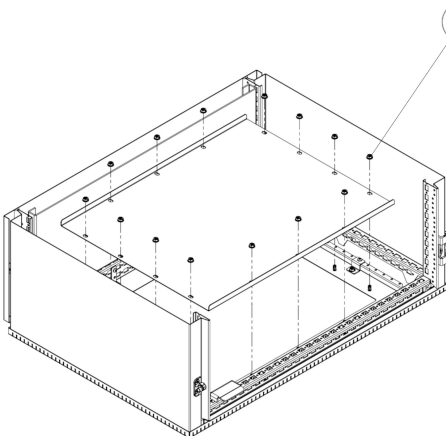



# BOTTOM PLATE MCSS-HP

Ref.	Pic.	Qty.
A	M6	14

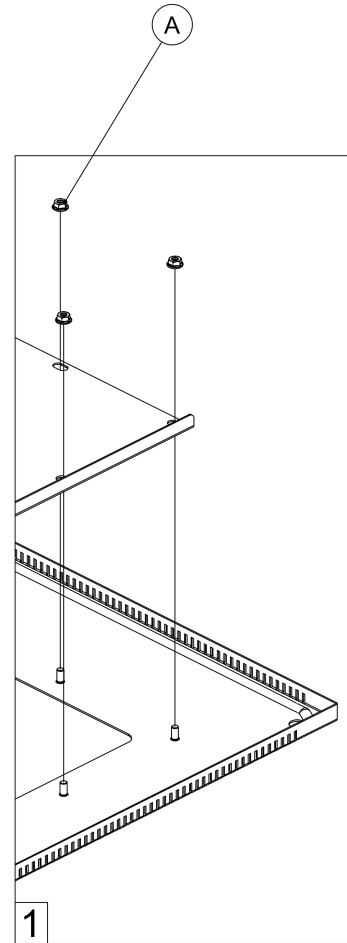
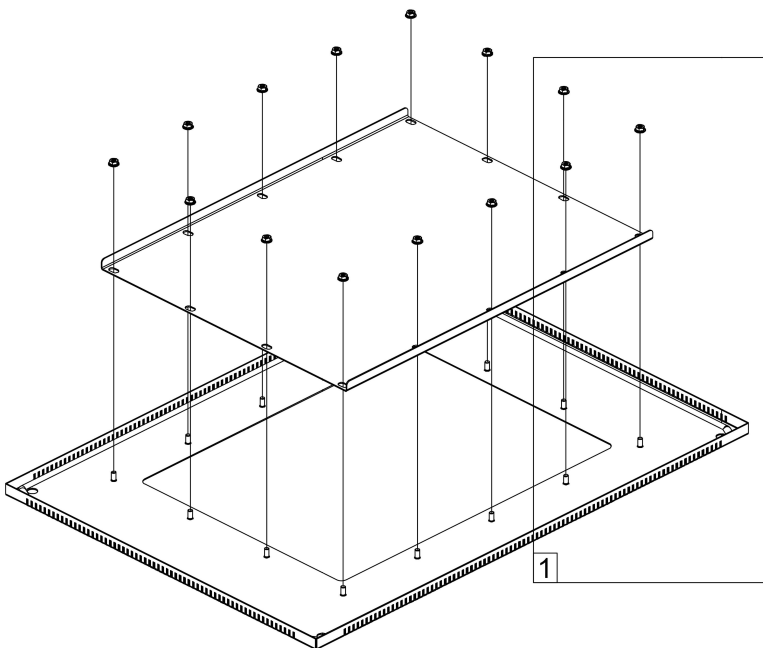
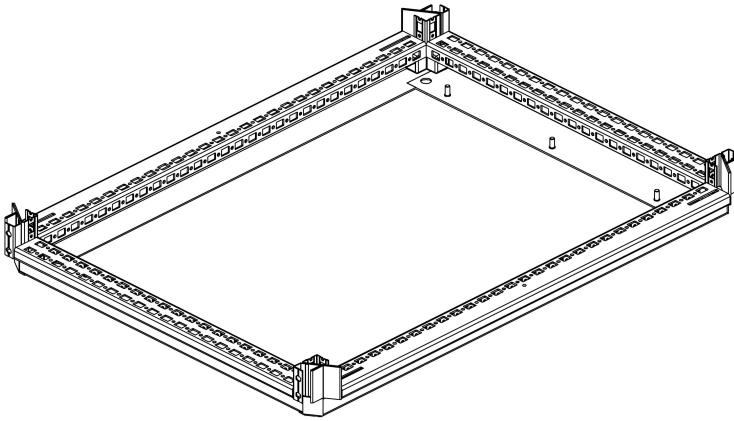
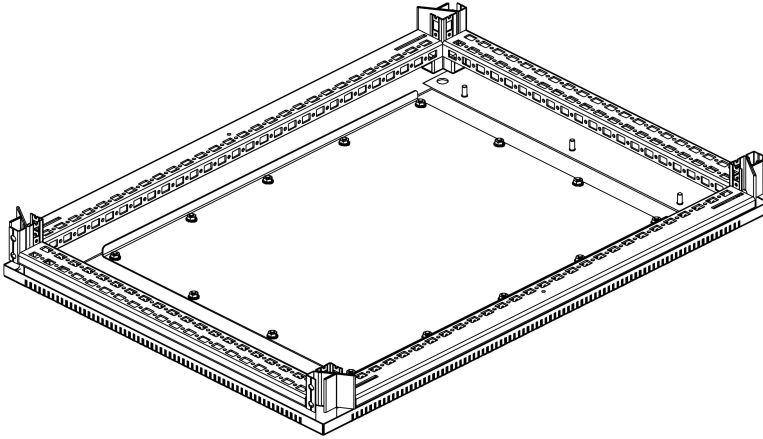



# MOUNTING PLATE

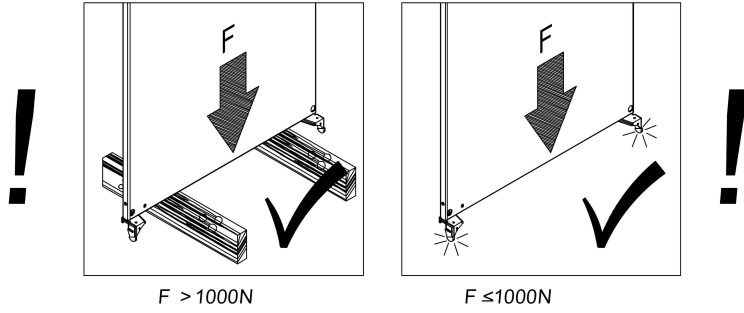

Ref.	Pic.	Qty.
A		2
B		2
C		2
D		1
E		1
F		1
G		1

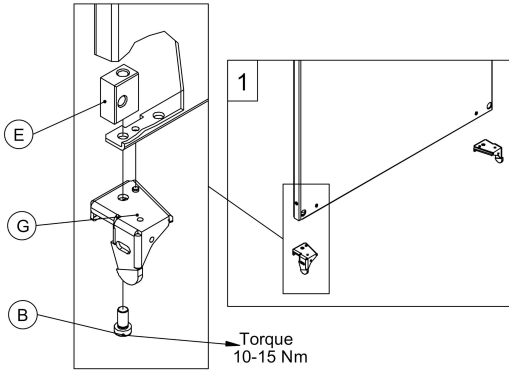

## MOUNTING

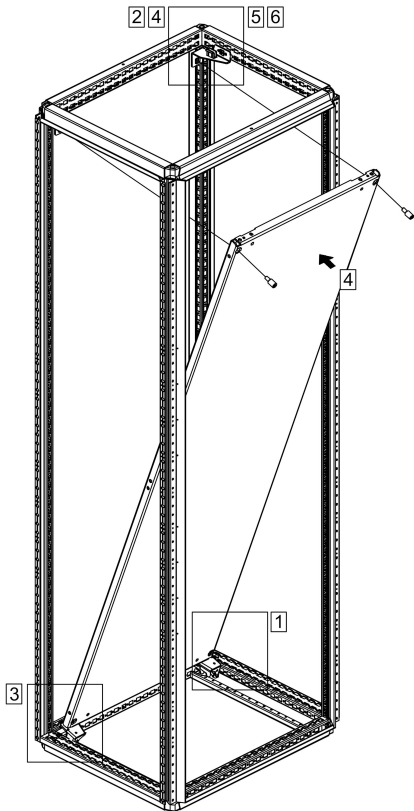
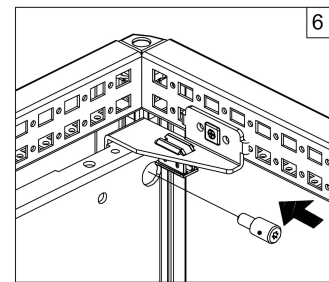
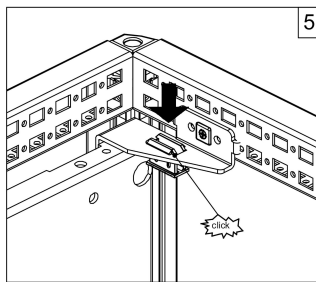
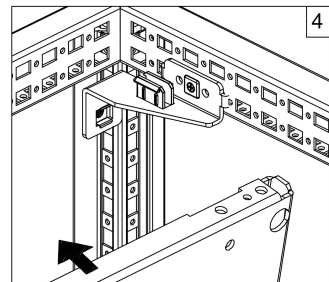
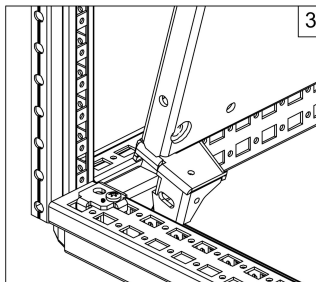
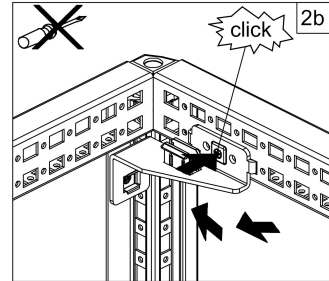
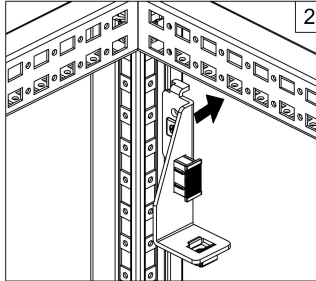

## UNMOUNTING

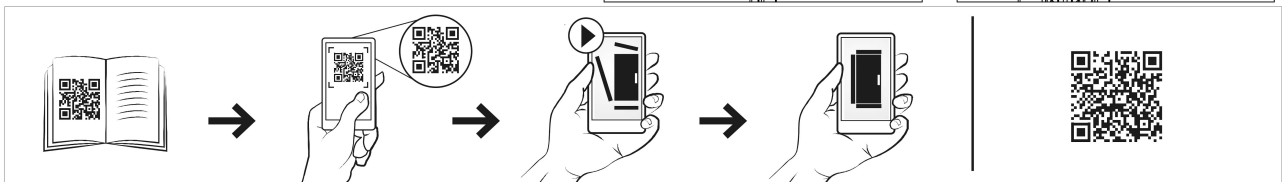
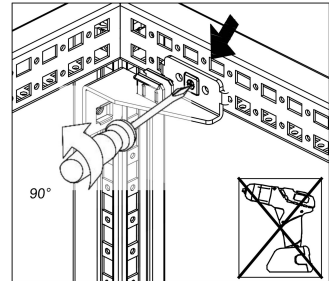
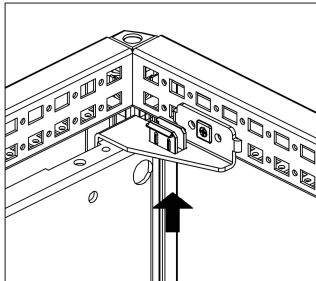



# MPD02

Ref.	Pic.	Qty.
A	M5X12	2
B	Bottom left	1
C	Bottom right	1

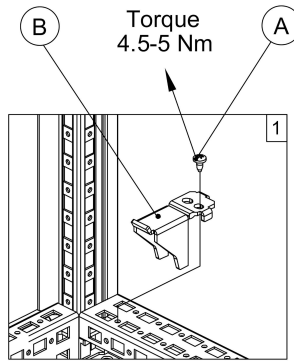
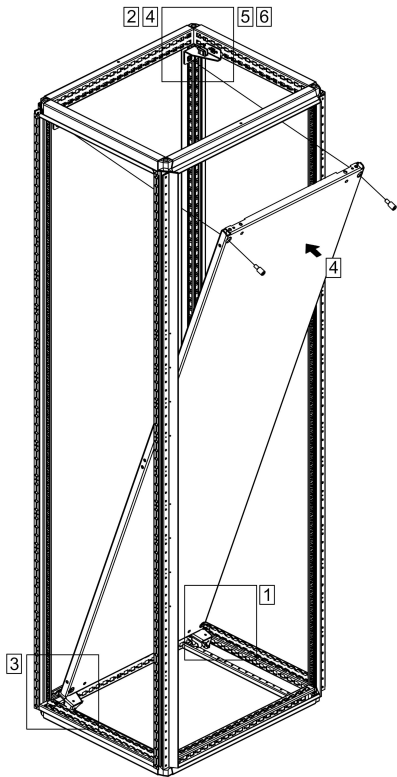

## MOUNTING

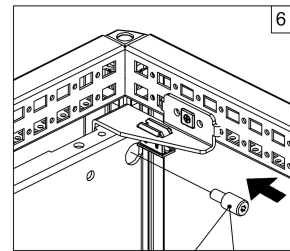
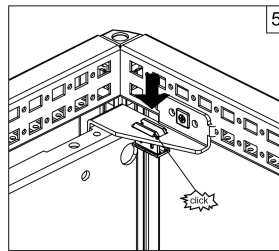
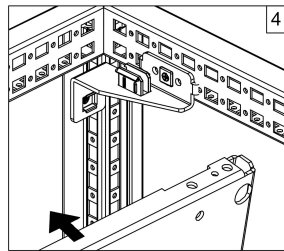
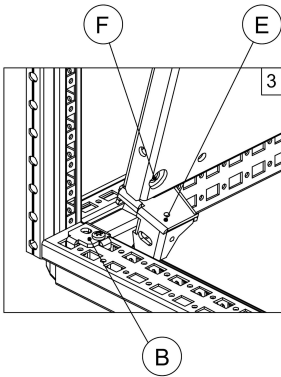
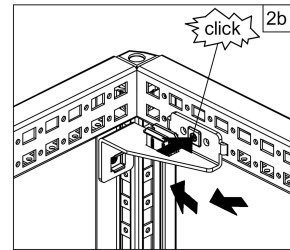
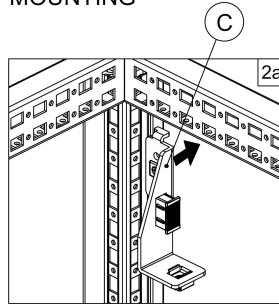

D Torque 4.5-5 Nm

## UNMOUNTING

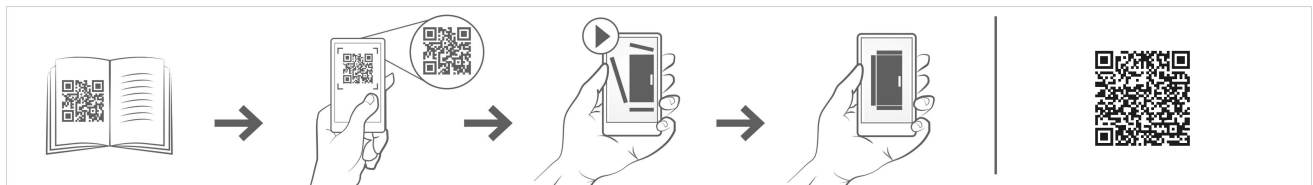
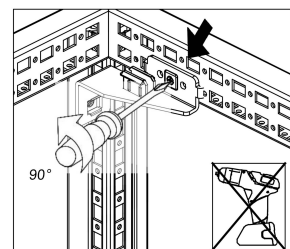
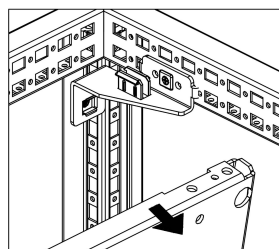
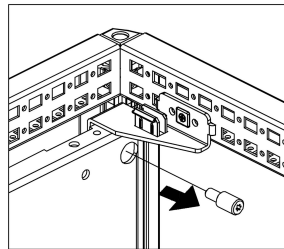
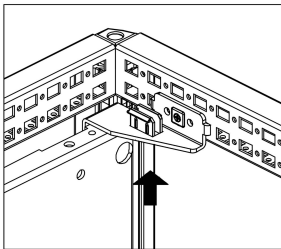

# SPM/SPMS

Ref.	Pic.	Qty.
A		16
B*	M6	16
C*	M6x16	16

## Side panel mounting on MCS-HP/MCSS-HP

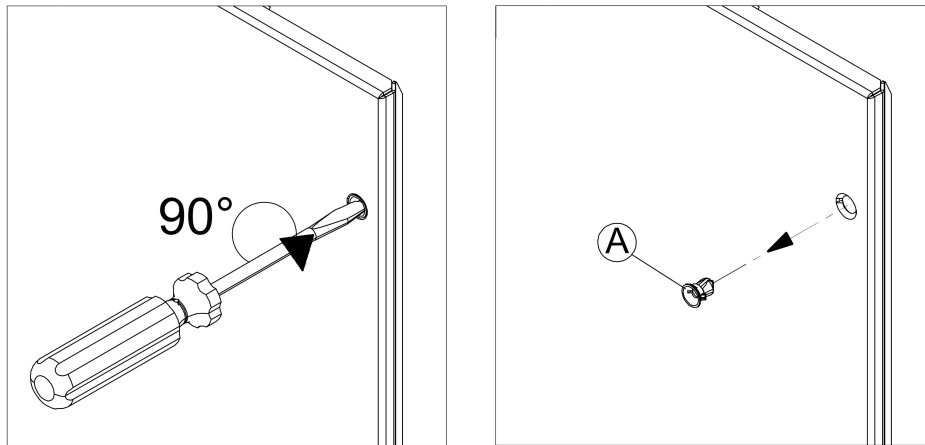

NOTE: Retainers delivered pre-assembled will be removed

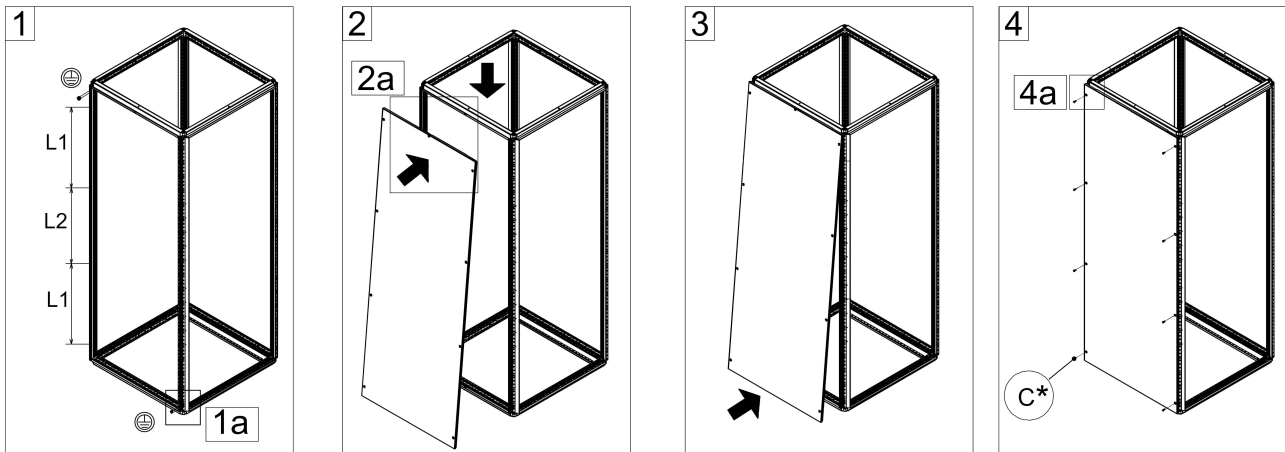

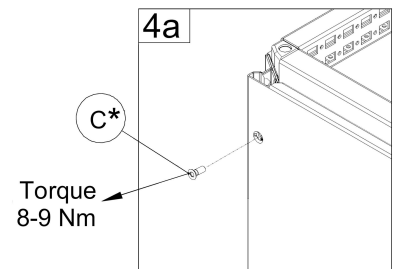
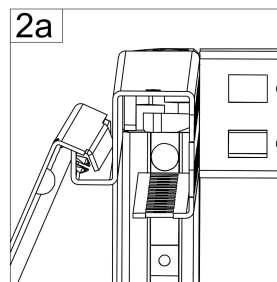
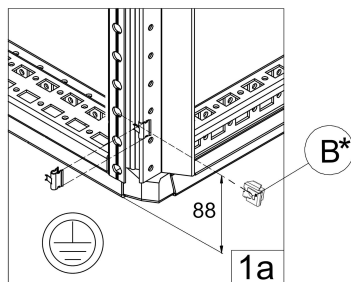

\* The components can be found in the enclosure kit

ENCLOSURE HEIGHT	L1	L2
2000	625	575
2200	675	675





# DW

Ref.	Pic.	Qty.
A	 M5x10	4
B		1
C		1

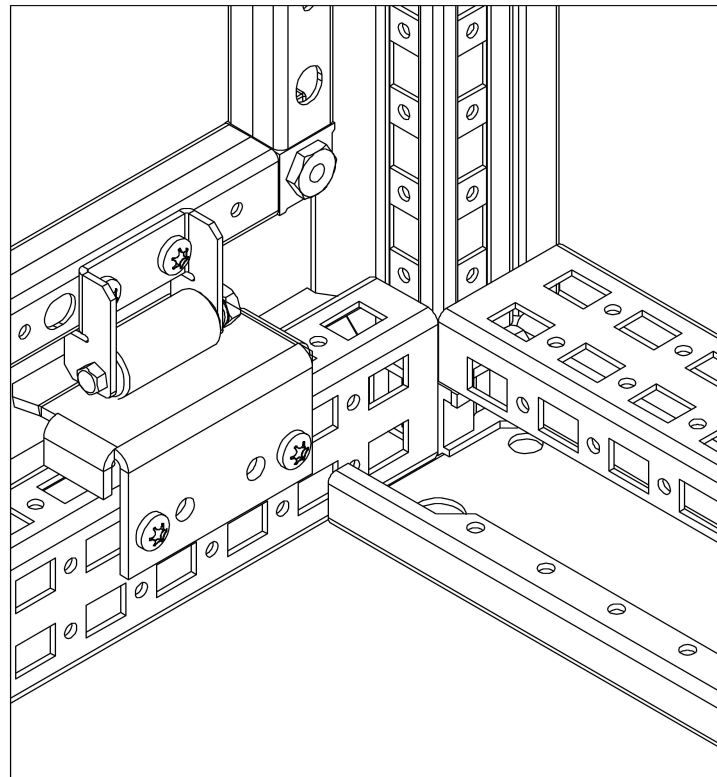
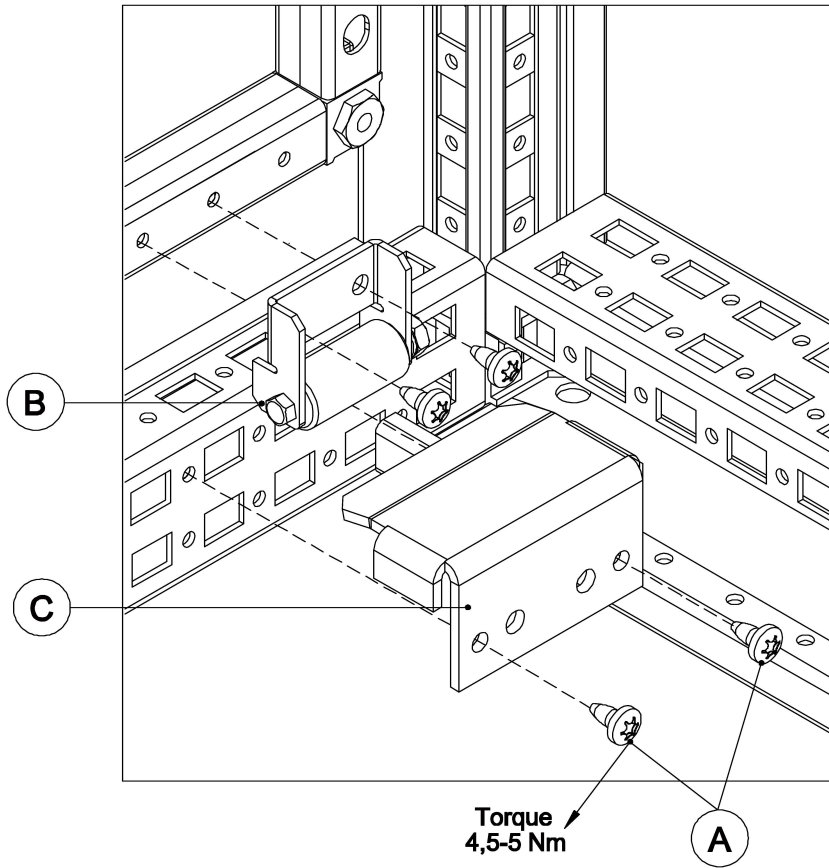

# HPPG01 Puzzle Gasket

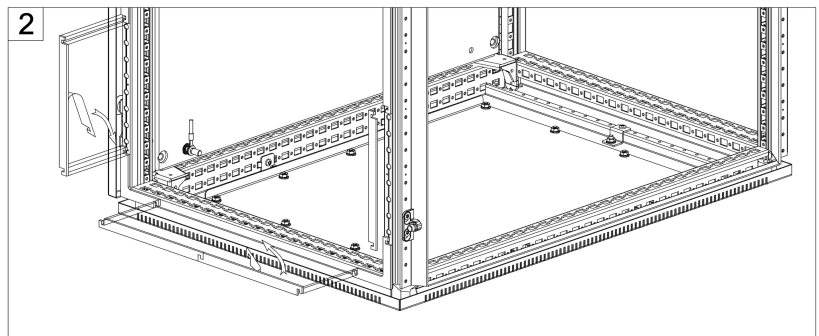
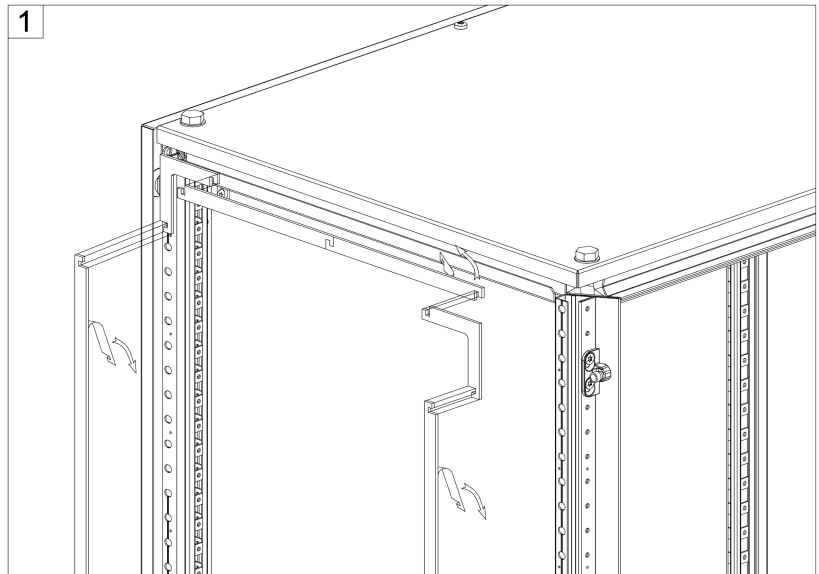
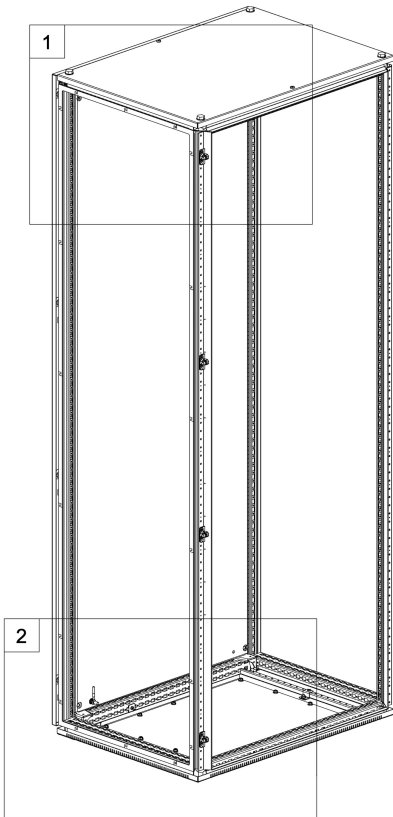

MCS20086HP MCSS20086HP MCS22088HP MCSS22088HP				
ENCLOSURE HEIGHT				
H=2000	4x	0x	2x	8x
H=2200	4x	4x	2x	8x
ENCLOSURE DEPTH				
D=600	-	0x	4x	0x
D=800	-	0x	6x	0x

\*To combine the enclosures side to side CCI06 and CCM04 are also required.



Ref.	Pic.	Qty.
A		24
B		6

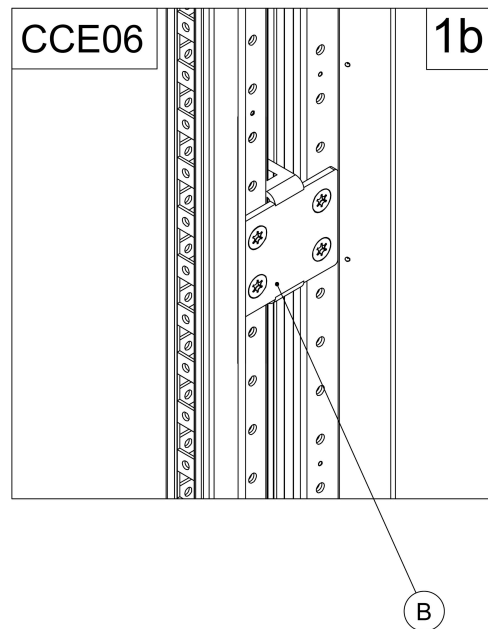
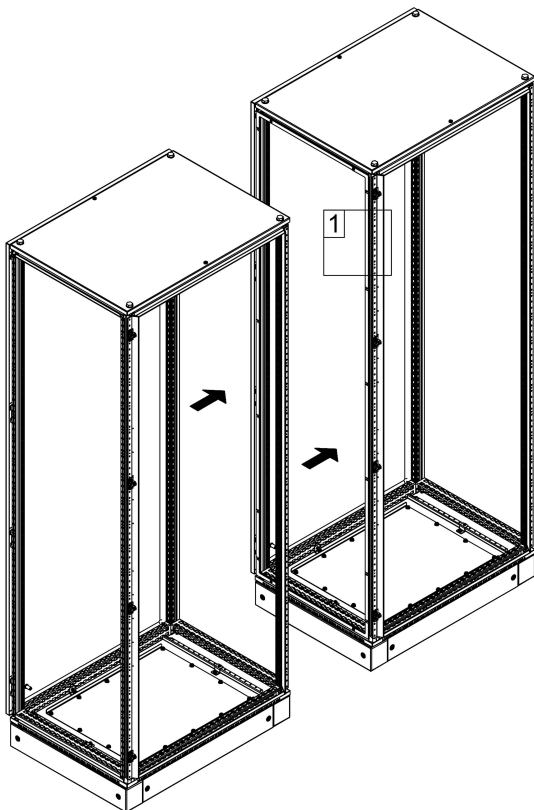
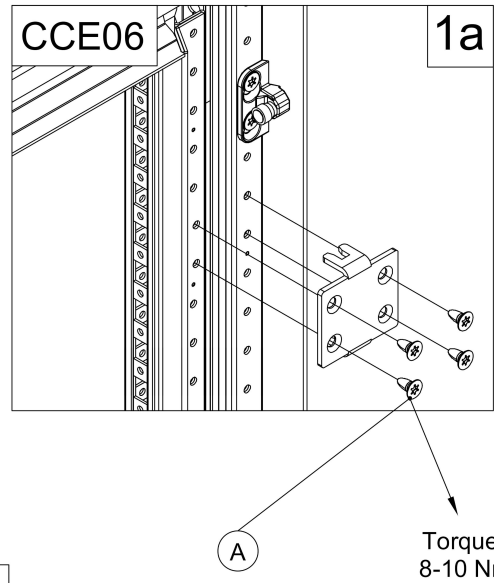
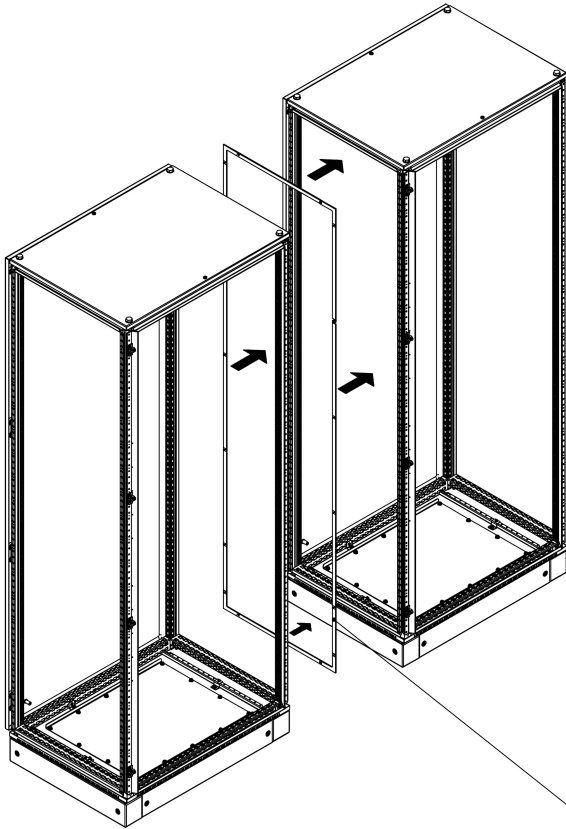

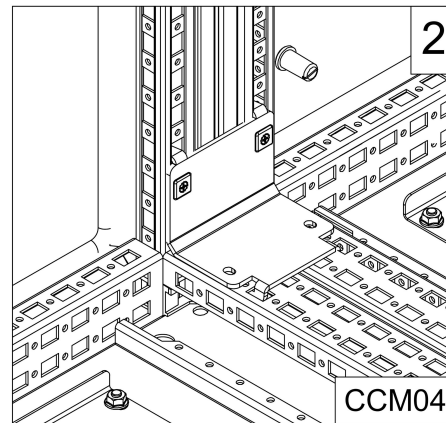
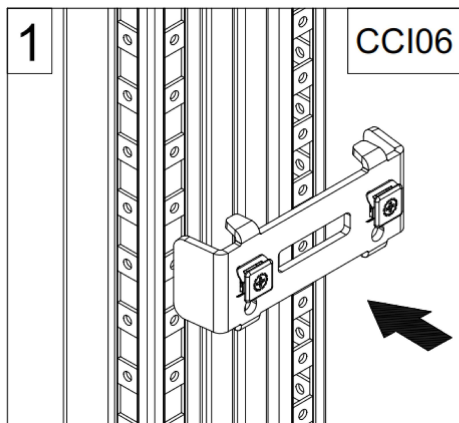
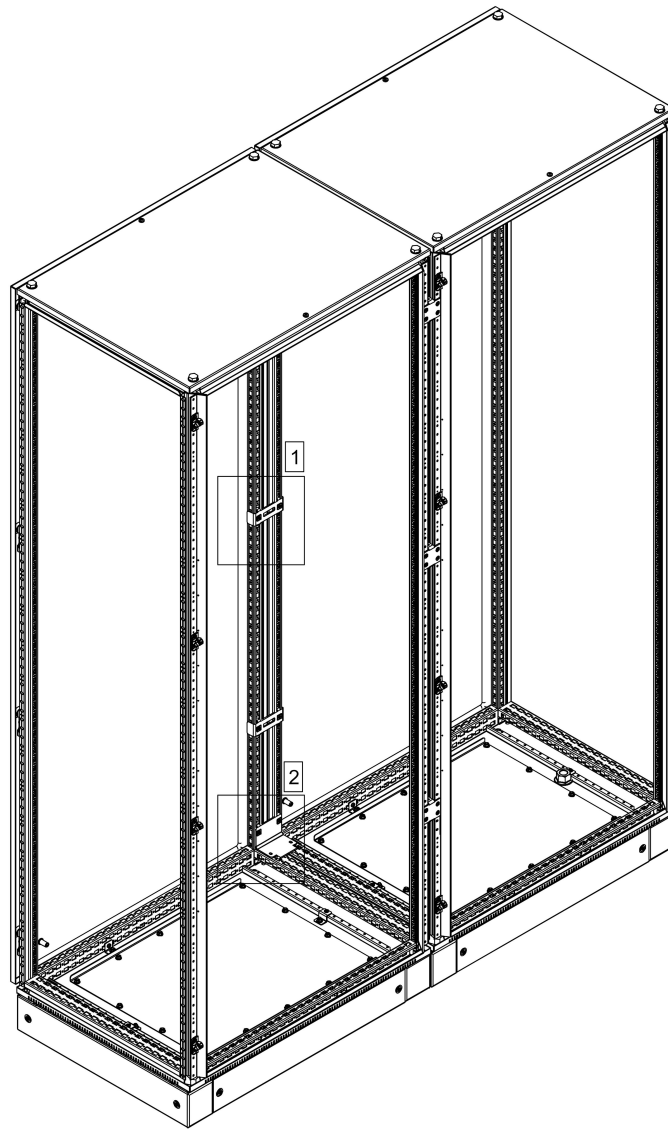



# CCM 04

Ref.	Pic.	
A		4
B		8

## MOUNTING

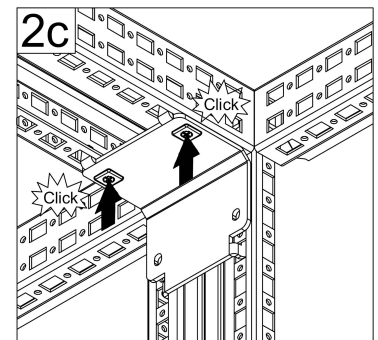
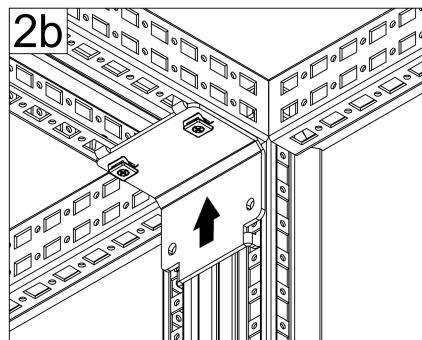
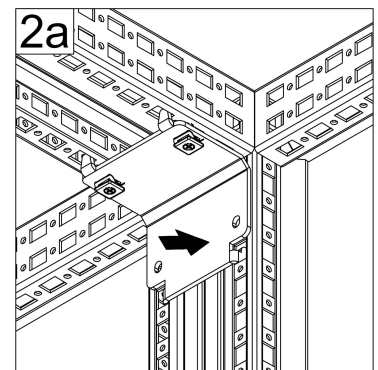
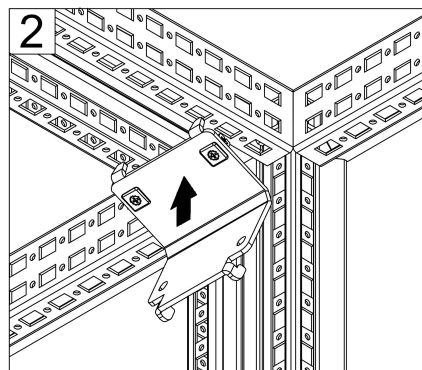
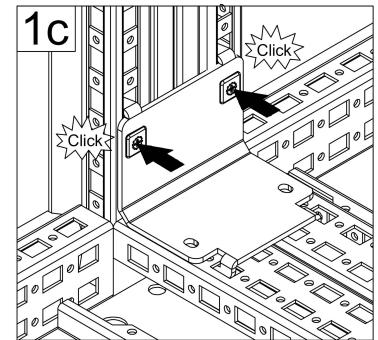
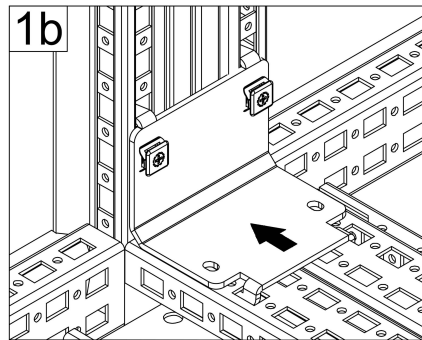
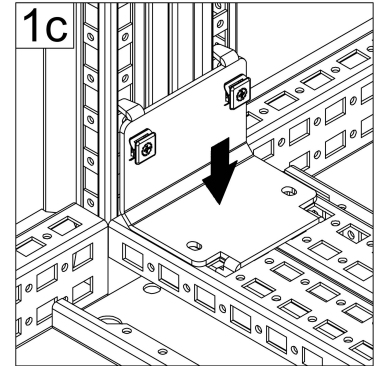
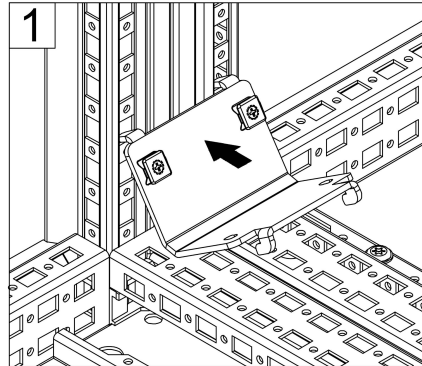
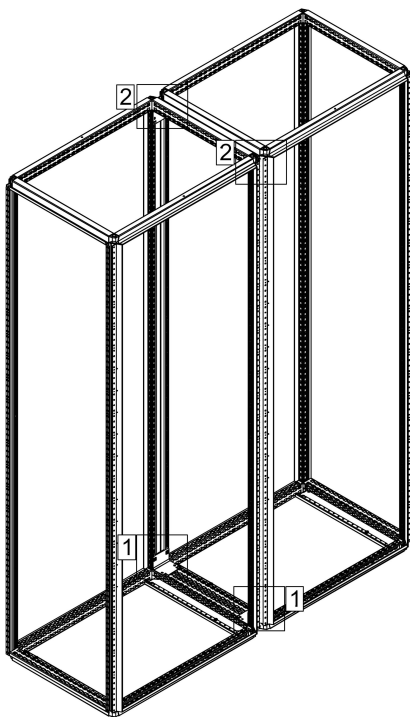
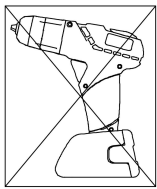
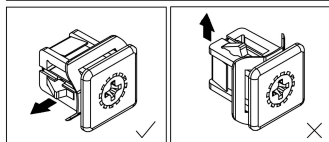
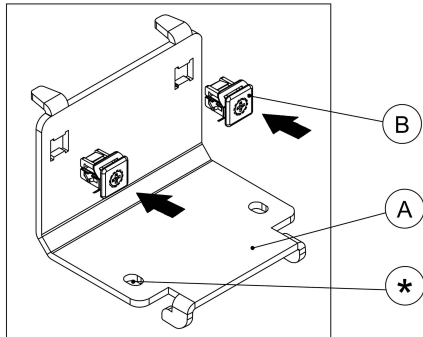

Note: It is mandatory for all four brackets to be installed at all four corners !

\* The fixation holes can be used to better fix the bracket to the frame, using cage nuts and screws !



Ref.	Pic.	Qty.
A		4
B		4
C		2
D		4

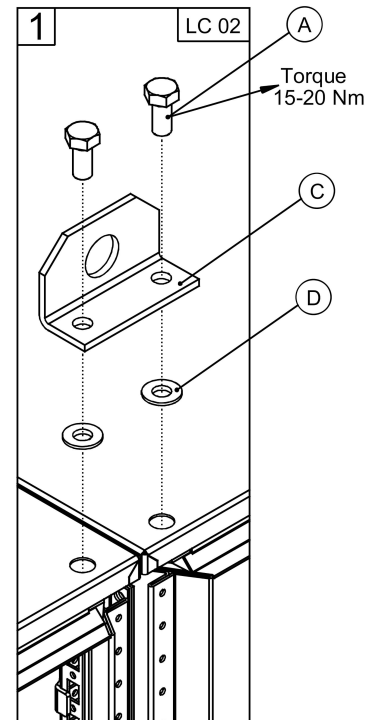
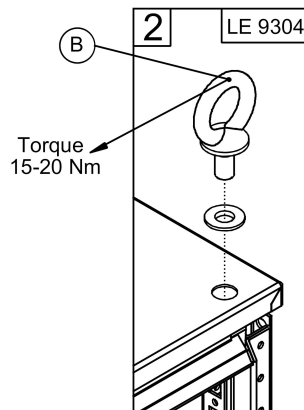
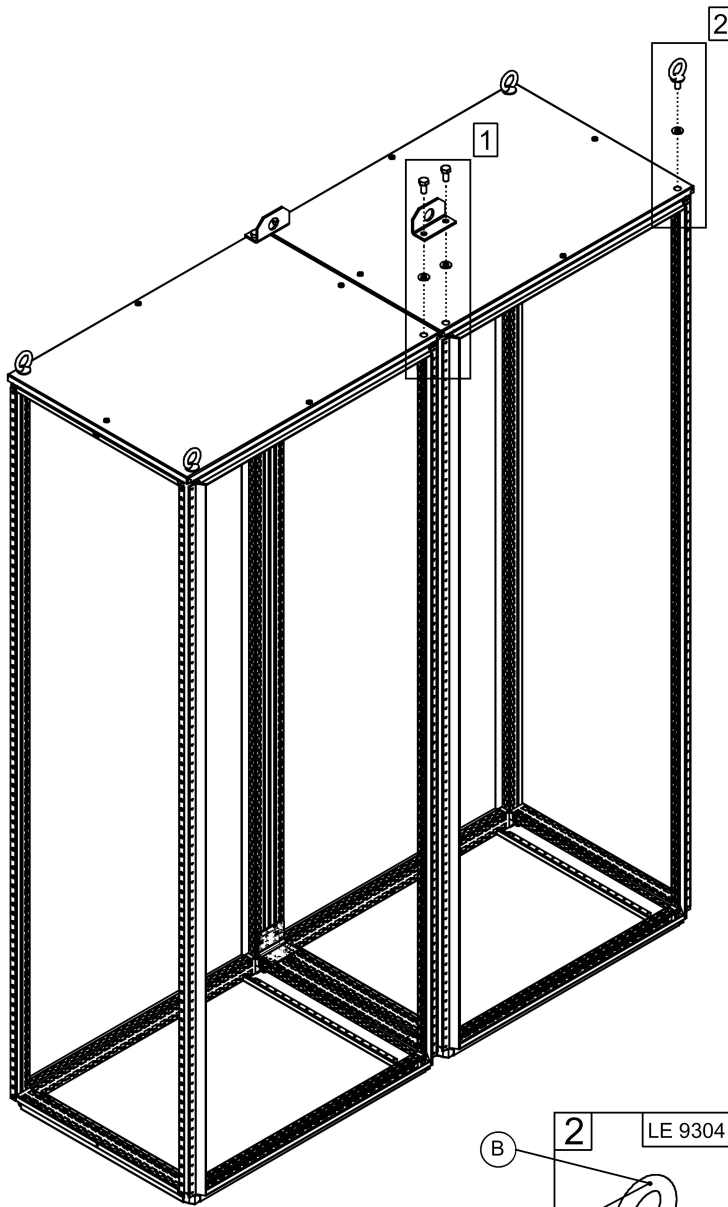

# DHN 180

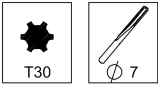

Ref.	Pic.	Qty.
A	M6x12	8

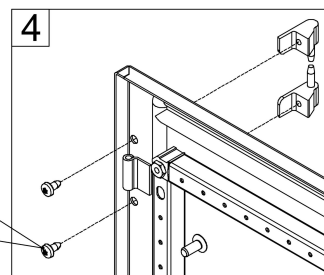
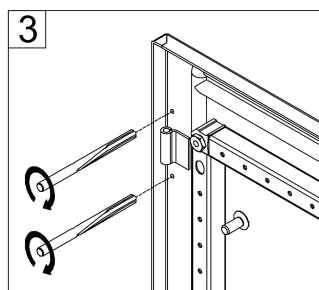
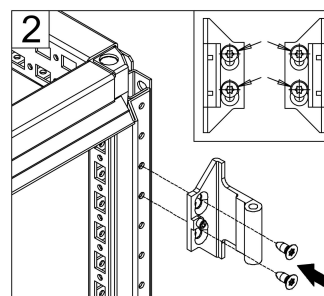
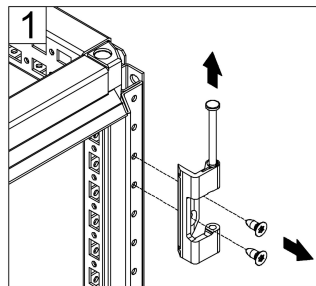
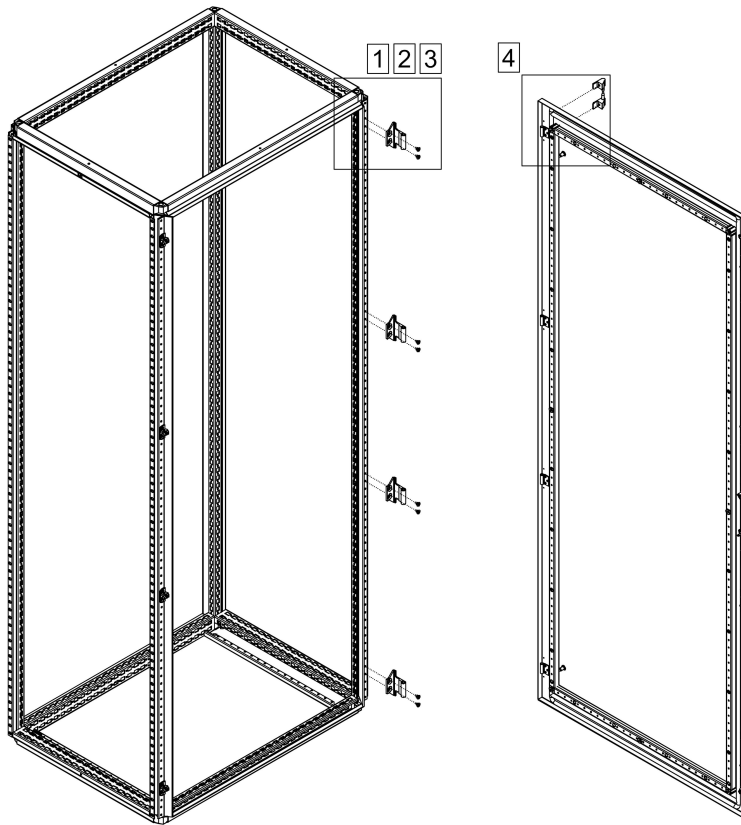



# DHN 180 DOOR ADJUSTMENT

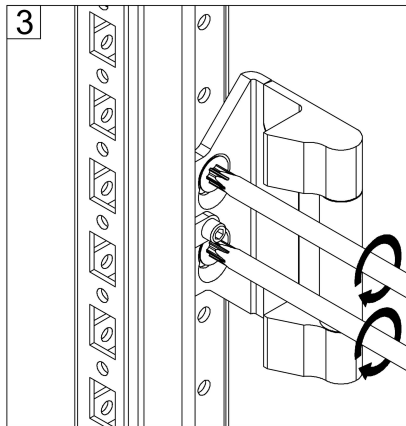
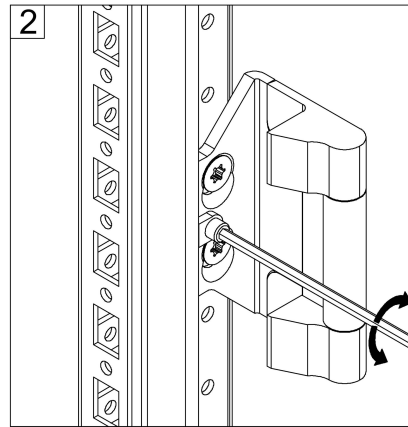
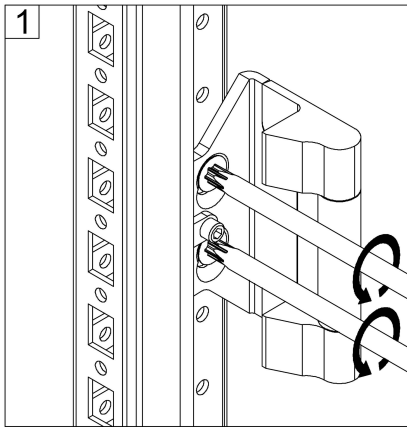
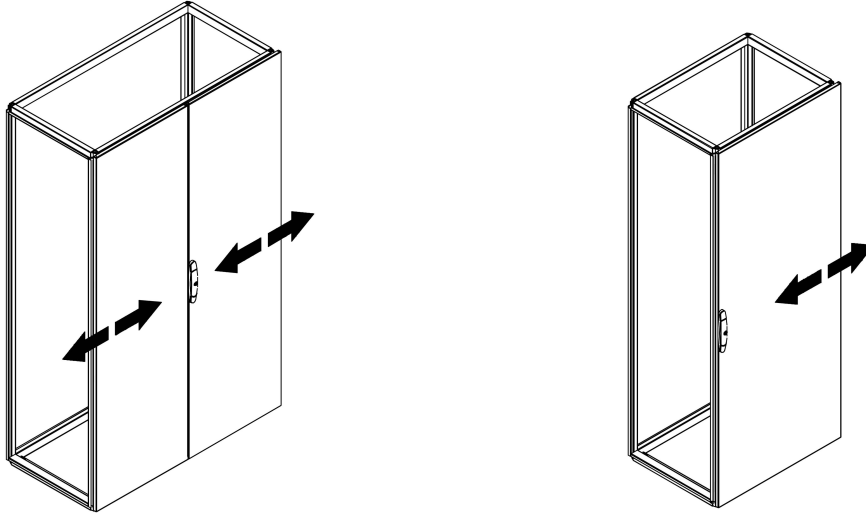

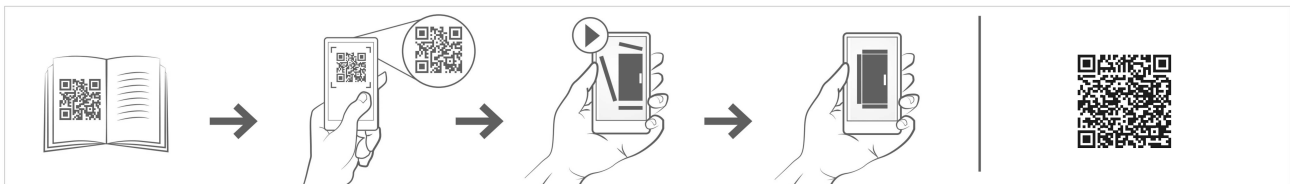
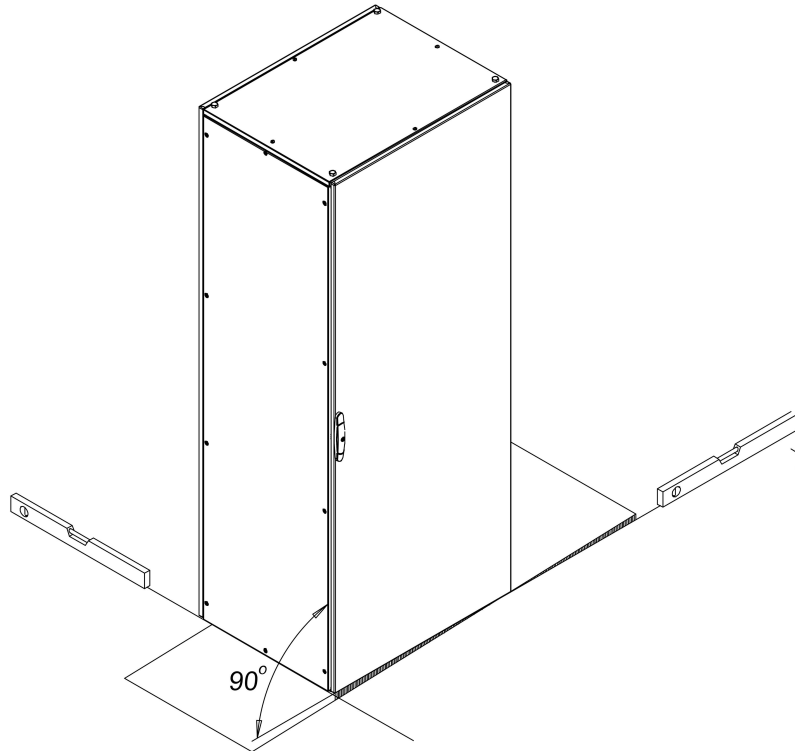
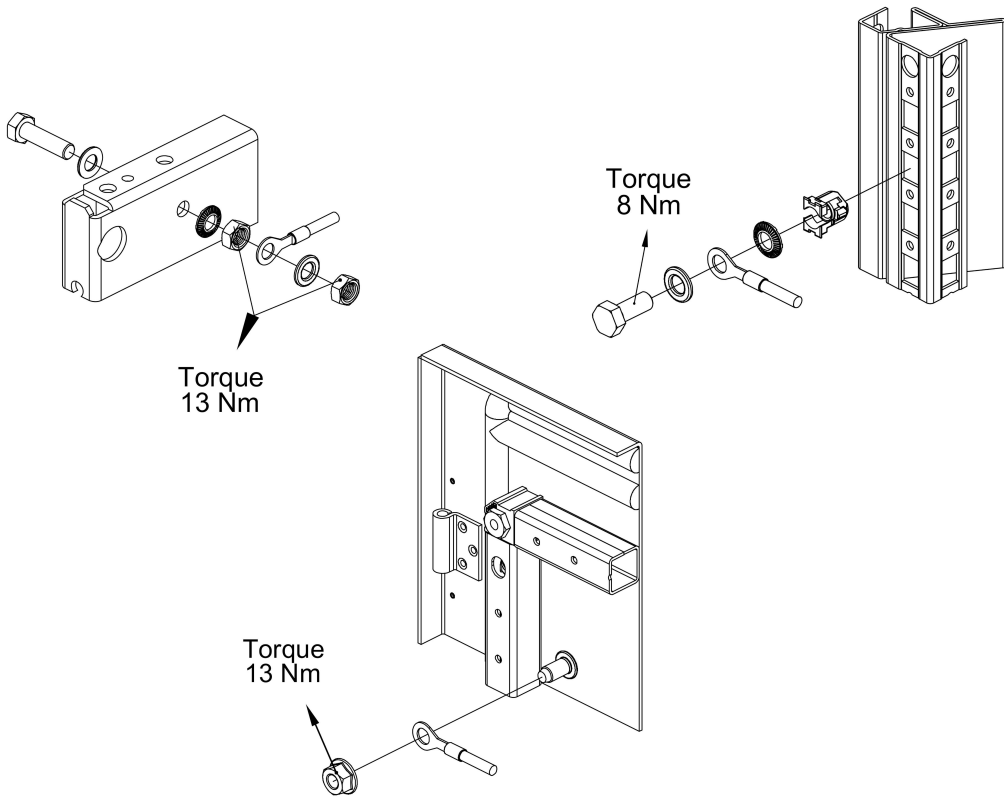

# CNM

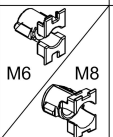
Ref.	Pic.	Qty.
A		1

