

Outdoor cooling units for door or wall mounting

Installation, operation and maintenance manual



EMO



TABLE OF CONTENTS

1. COOLING UNIT APPLICATION	3
1.1 Intended use	3
1.2 Improper use.....	3
2. SUPPLY	3
3. UPDATES	3
4. TECHNICAL FEATURES.....	3
5. TRANSPORT AND HANDLING.....	3
6. INSTALLATION	3
7. CONDENSATE DISCHARGE HOSE.....	3
8. ELECTRICAL CONNECTION	4
8.1 Safety	4
8.2 Alarm management cable.....	4
9. FIRST START UP AND ADJUSTMENT	4
10. MAINTENANCE	4
11. TECHNICAL INFORMATION	4
11.1 Operating principle	4
11.2 Safety devices.....	4
11.3 Energy savings.....	4
11.4 Disposal	4
12. TROUBLESHOOTING	5
13. PICTOGRAMS	6
14. TECHNICAL DATA F.14	8
15. PERFORMANCES F.15.....	9
16. DIMENSIONS F.16.....	10
17. SPARE PARTS F.17.....	11
18. GUARANTEE	12
19. ASSISTANCE SERVICE.....	12
20. NOTES	13

ATTENTION!

Read carefully and completely before installation. Keep the manual until unit decommissioning.

1. COOLING UNIT APPLICATION

The **EMO** series cooling units described in this manual are designed and built to cool the air inside electrical switchboards in order to protect components sensitive to thermal shock.

At the same time, the cooling units provide **IP54** ingress protection against contaminating and aggressive/corrosive substances.

1.1 Intended use

The **EMO** cooling unit must be used:

- For cooling electrical switchboards for external use
- With external air temperature between a minimum of -20°C and a maximum of $+50^{\circ}\text{C}$ ($+55^{\circ}\text{C}$ for units where this is expressly indicated on the data plate)
- Within the voltage supply limits indicated on the data plate of the cooling unit and also given in chapter 14 of this manual
- Away from any sources of heat or hot air
- In an environment with adequate air exchange
- On switchboards with **IP54** rating or higher. If these requirements are not respected, excessive condensation build-up may occur. As a consequence, cable entry points or any other openings in the cabinet should be well sealed.

To ensure correct operation, the specified scheduled maintenance operations (see section 10) must be performed regularly. Incorrect or careless use may cause irreparable damage to the cooling unit and may lead to hazardous situations.

1.2 Improper use

The **EMO** cooling unit must NOT be used:

- Under any condition except those described in section 1.1
- Outdoors, with excessive concentration of solid contaminants and/or aggressive chemical contaminants
- With the doors of the electrical switchboard open, or installed on enclosures without a minimum **IP54** rating, due to excessive condensate formation
- With the temperature set below the dew point of the ambient air
- In explosive atmospheres, or those with aggressive chemicals or high concentrations of dust or oil suspended in the air
- In potentially inflammable atmospheres
- With the condensate line closed or blocked off, or in any case in which the condensate is not allowed to run off freely
- Without the front panel
- With the cooling unit intake and outlet air flows obstructed by walls or objects that are too close To this end, check the minimum distances as regards the external air flow (figure **F.02**), and make sure there are no obstructions caused by the switchboard components as regards the internal air flow.

2. SUPPLY

Inside the packaging you will find:

- 1 Cooling unit
- 1 Installation, operation and maintenance manual
- 1 CE conformity certificate
- 1 Test certificate
- 1 A4 drilling template
- 1 Installation kit containing (**F.04**):
 - Flanged nuts (**p.1**)
 - Flat washers (**p.2**)
 - Grub screws (**p.3**)
- 1 Self-adhesive sealing strip (**F.04, p.4**)
- Handling brackets (**F.03**)

3. UPDATES

TEXA INDUSTRIES S.r.l. reserves the right to update its products and the corresponding manuals based on technical progress without prior notice. Please note that at the time of sale, this manual and the corresponding product may not be considered inadequate only because they are not subject to the above-mentioned updates.

4. TECHNICAL FEATURES

(figures **F.14** and **F.15**)

The unit's technical features and CE marking are given on the data plate attached to the cooling unit.

5. TRANSPORT AND HANDLING

During transport and storage the cooling unit must be kept in a vertical position, as indicated on the packaging (figure **F.01**), and must not be exposed to temperatures above 70°C or below -30°C . Upon receipt, check that the packaging has not been damaged during shipping.

To lift the cooling unit in a safe manner, use the handling brackets installed on the top of the unit (figure **F.03**).

6. INSTALLATION

Installation of the unit should only be performed by qualified and authorised personnel.

The cooling unit must be installed with the enclosure air intake hole in the highest possible point.

Ensure the fixing elements and couplings will not interfere with the equipment inside the enclosure itself.

The unit must be installed in the vertical position indicated. Maximum permitted deviation from the vertical is 2° .

Disconnect power before starting any work inside the switchboard.

The cooling unit must be installed on the outside of the electrical switchboard using the standard accessory kit supplied with the unit. Drill the holes and make the cuts required in the switchboard (figure **F.04**) using the supplied drilling template.

Fit the sealing strip on the cooling unit on the side connected to the enclosure and follow the assembly diagram (figure **F.04**).

7. CONDENSATE DISCHARGE HOSE

The condensate which, depending on the ambient temperature and humidity conditions, forms on the heat exchanger which cools the enclosure air, is not a malfunction but a normal phenomenon of the cooling unit.

The condensate is taken outside the cooling unit via a hose at the bottom of the unit (figure **11.B**). A plastic hose must be connected to this outlet to carry the condensate to another point, allowing it to be discharged where there can be no slipping hazard for personnel.

In this case, make sure the condensate flows without any hindrance. Avoid horizontal lengths of more than 0.5 metres, uphill sections and the accidental formation of traps (figure **F.05**). The end of the condensate discharge hose must always be free and not underwater, so never place the end of the discharge hose inside a condensate collection container (figure **F.07**).

The condensate drain connection can also be taken out the side of the cooling unit by modifying the position of the internal rubber tube (figure **F.11 A**).

If the cooling unit is used with the doors of the enclosure open, excessive quantities of condensate will form and this is an unauthorised condition of use (figure F.07). We suggest using a position switch on the door connected to the cooling unit's digital input to stop the unit if the door is opened. (See section 8.2)

8. ELECTRICAL CONNECTION

8.1 Safety

⚠ Warning! Electrical connections must only be performed by specialised and authorised personnel. Switch power off to the enclosure before making the connection.

Check that there is no power to the switchboard and that the supply voltage corresponds to the characteristics given on the cooling unit's data plate. The power supply must be protected using appropriate time-delay fuses (type T) or circuit breakers with K-curve, as per the indications given in table F.14. Connect the power-supply cable as shown in figure F.14. Ensure you respect the sequence R-S-T. Disconnect the cooling unit before performing testing on the enclosure.

8.2 Alarm management cable

(figure F.13)

The alarm signal output from the cooling unit can be taken from wires **80** and **81** using a two-pole cable.

9. FIRST START UP AND ADJUSTMENT

If, prior to installation, the cooling unit was left in an incorrect position (figure F.01), wait at least 8 hours before switching it on. Otherwise, 30 minutes is more than enough time for the oil to return to the compressor, after which the cooling unit can be powered up. The enclosure air intake fan starts working immediately, making the temperature inside the enclosure even.

If this temperature exceeds the set point on the regulator thermostat, both the compressor and external air fan will turn on, causing the cooling cycle to start. This then stops when the inside temperature reaches the lower limit of the operating temperature differential, which has a fixed value of 4 K. The thermostat is factory-set to 35°C. Use the thermostat located inside the cooling unit to adjust the temperature set-point. The graduated scale allows you to set the required temperature between 20 and 46°C (figure F.10). In order to save energy and minimise the production of condensate, it is nevertheless recommended it not be set below 30°C.

10. MAINTENANCE

⚠ Warning! Caution! Before embarking on any maintenance work, cut the current to the enclosure.

The cooling unit is the low maintenance type. The only maintenance required is for the internal components, which should be checked regularly, as indicated in the table given in this section, and cleaned with compressed air at a maximum pressure of 4 bar (figure F.08). Any repairs that may need doing must only be performed by specialised and authorised personnel.

Job	Frequency
Check, clean and, if necessary, replace the air filter	Every 2 weeks
Check the external air heat exchanger and clean if necessary.	Every 3 months
Check effectiveness of the condensate discharge.	Every 3 months
Check the fans for any overheating or excessive vibrations.	Every 6 months

11. TECHNICAL INFORMATION

11.1 Operating principle

The cooling unit for electrical switchboard enclosures works on the basis of a refrigeration circuit consisting of four main components: compressor, evaporator, condenser and expansion device (figure F.09). The circuit is hermetically sealed and the refrigerant circulates inside it. The refrigerant used, depending on the cooling unit model, is R134a, R407C or R410a, all chlorine free and harmless to the ozone layer. The unit is divided into two hermetically separated sections where the ambient air and enclosure air do not come into contact with one another and are treated separately. The compressor (CP) compresses the refrigerant, taking it to a high pressure and high temperature. The compressor then pushes the refrigerant through a heat-exchanger coil, called the condenser (C), where it is cooled by ambient air, thus passing from the gas to the liquid state. In this state it then collects in the receiver (R), from which it then passes through the thermostatic expansion valve (EXP), where it vaporises. It is then received by the heat exchanger coil, called the evaporator (E), by means of which it absorbs heat from the enclosure air and passes from a liquid state to gas. The enclosure is cooled down in this manner. The gaseous refrigerant is then drawn back into the compressor and this cycle is repeated.

11.2 Safety devices

The refrigeration circuit is fitted with a high-pressure pressure switch Hp and a low-pressure pressure switch Lp (figure F.09) set to the maximum and minimum working pressures, respectively, of the cooling unit. If one of these thresholds is exceeded, the pressure switch stops the compressor's operation. They reset automatically. The fans and compressor have an (internal or external) thermal cut-out switch that stops them in the case of overheating.

11.3 Energy savings

To optimise energy savings, the cooling unit is fitted with a pressure-switch speed regulator (RLF) which adjusts the speed of the condenser fans based on the pressure in the refrigeration circuit, which in turn depends on the ambient temperature.

11.4 Disposal

⚠ Caution! The cooling unit contains R134a, R407 or R410A refrigerant, depending on the model, as well as small quantities of lubricating oil.

These are polluting substances and must not be dumped. Replacement, repairs and final disposal must be performed by experts.

Note: Keep the unit's documentation in a safe, dry place.

12. TROUBLESHOOTING

Malfunction	Conditions	Causes	Remedy	
It fails to cool	The internal fan works, the external fan and compressor do not work.	The temperature inside the enclosure is lower than what is set on the adjustment thermostat.	This is not a malfunction of the cooling unit. To verify functioning when testing, lower the thermostat setting until the compressor and external fan start working and then reset the thermostat.	
		The adjustment (or antifreeze) thermostat has failed	Change the adjustment (or antifreeze) thermostat	
	No component works	No electricity getting to the unit.	This is not a malfunction of the cooling unit. <ul style="list-style-type: none"> • Make sure the power cable has been connected well to the terminals. • Check that the cubicle doors and switches are closed 	
	Compressor, external and internal fan work	Cooling unit empty of fluid	Call a refrigeration expert or the Manufacturer's Technical Assistance Service	
		Compressor mechanical failure	Call a refrigeration expert or the Manufacturer's Technical Assistance Service	
	Compressor and external fan work, internal fan does not work	Internal fan capacitor failed	Change the internal fan's capacitor	
		Internal fan failed	Change the internal fan	
	External and internal fan work, compressor does not work	Compressor's amperometric protector failed (external to the compressor, where present)	Relay or PTC for compressor starting failed	Change the relay or PTC for compressor starting
			Capacitor for compressor starting failed (where present)	Change the capacitor for compressor starting
		Compressor motor electrical failure	Call a refrigeration expert or the Manufacturer's Technical Assistance Service	
High pressure safety switch failed		Call a refrigeration expert or the Manufacturer's Technical Assistance Service		
Compressor contactor failed (where present)		Change the contactor		
It is not cooling enough		External and internal fans work, compressor works all the time	Cooling unit under sized for the heat dissipated inside the enclosure	Change the cooling unit with another of greater capacity
	Inside fan works, external fan and compressor work irregularly	Antifreeze thermostat triggered (where present)	<ul style="list-style-type: none"> • Clean the evaporator coil • See if there are any obstacles inside the enclosure to hinder the flow of recycling air 	
		Insufficient gas in the cooling unit	Call a refrigeration expert or the Manufacturer's Technical Assistance Service	
		Thermostat set point incorrect	Check thermostat setpoint	
	External and internal fans work, compressor works irregularly	High pressure safety switch triggered: <ul style="list-style-type: none"> • Ambient temperature over the maximum working limit • Heat exchanger coil (condenser) either dirty or clogged 	<ul style="list-style-type: none"> • Ventilate the premises where the enclosure is installed to keep ambient temperature lower. • Clean the exchanger with compressed air and detergent 	
			Thermal protector inside the compressor triggered: <ul style="list-style-type: none"> • Ambient temperature over the maximum working limit • Heat exchanger coil (condenser) either dirty or clogged 	<ul style="list-style-type: none"> • Ventilate the premises where the enclosure is installed to keep ambient temperature lower. • Clean the coil with compressed air and detergent
	Too much condensate forming	Enclosure door open	Too much ambient air inside the enclosure	This is not a malfunction of the cooling unit. Close the enclosure door or disable the cooling unit
Enclosure door closed		Enclosure protection level is below IP54	This is not a malfunction of the cooling unit. Seal enclosure openings, e.g. for passage and upward path of wires	
		The enclosure/cooling unit connecting seal has been fitted incorrectly	Check seal and remedy	

13. PICTOGRAMS

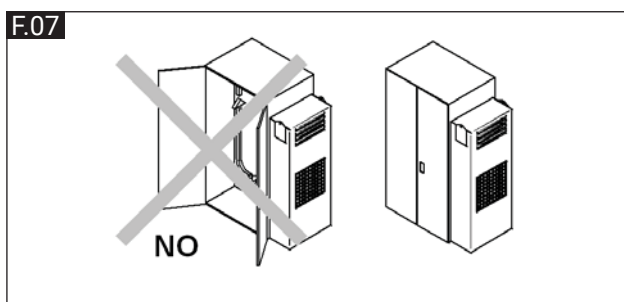
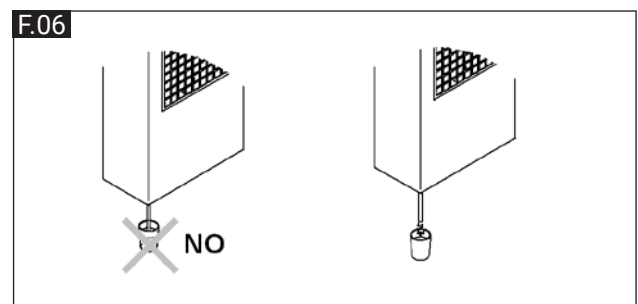
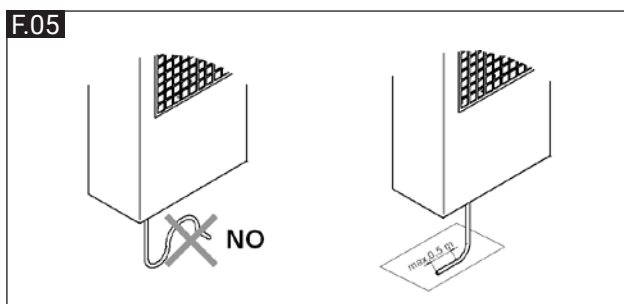
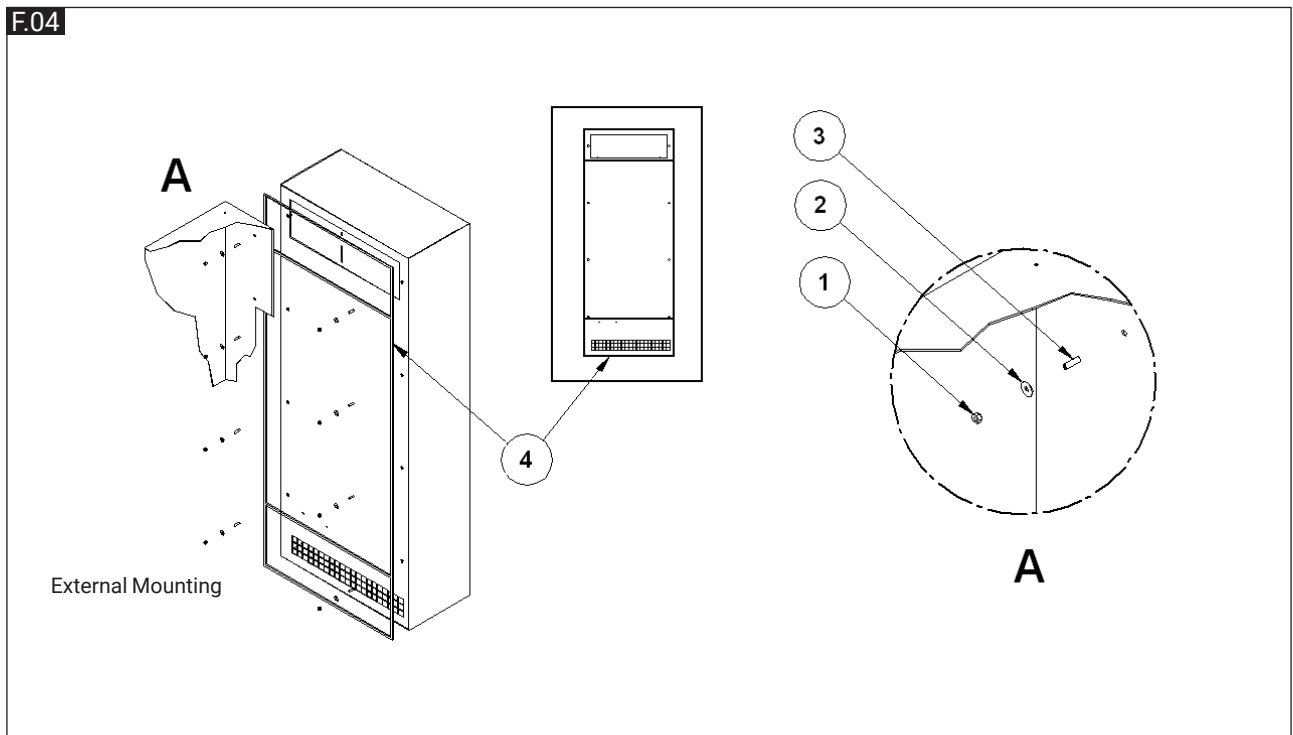
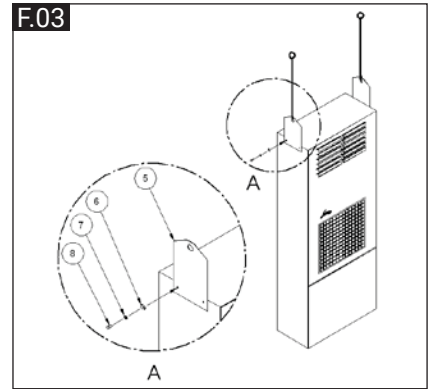
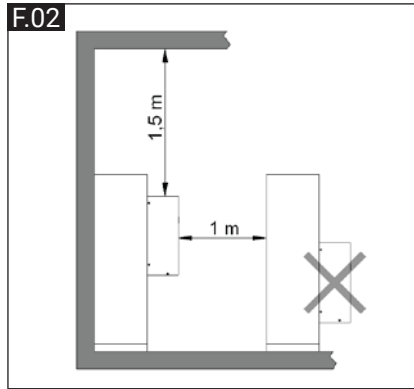
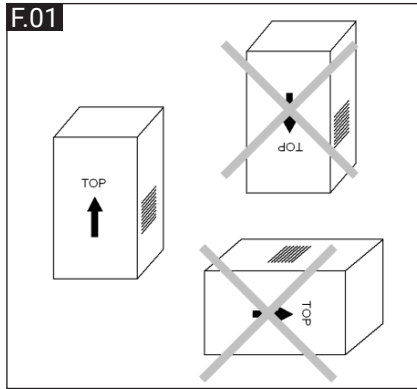

13. PICTOGRAMS

F.08

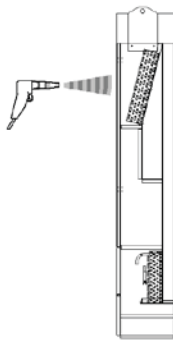

F.09

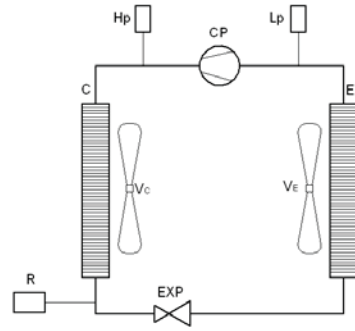

F.10

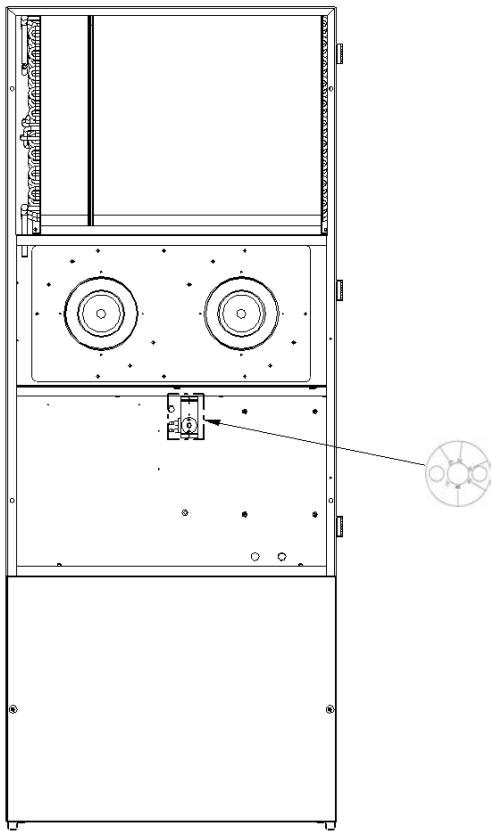

F.11

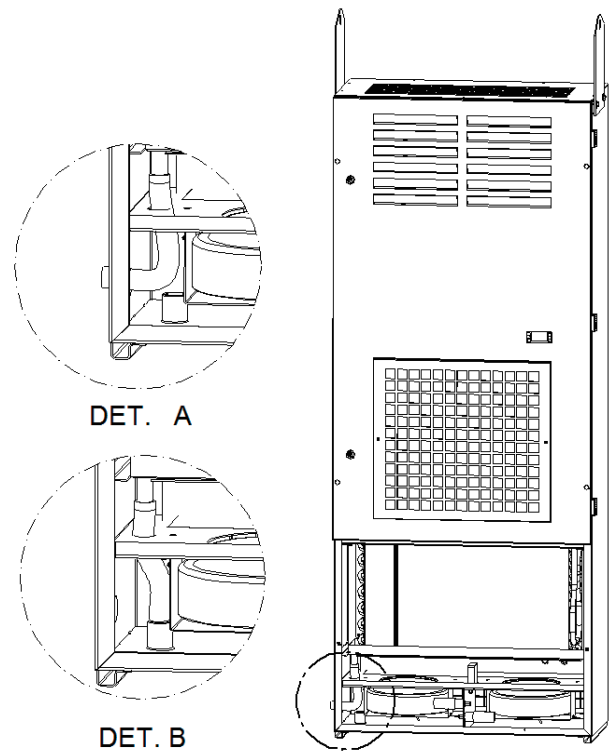

F.12

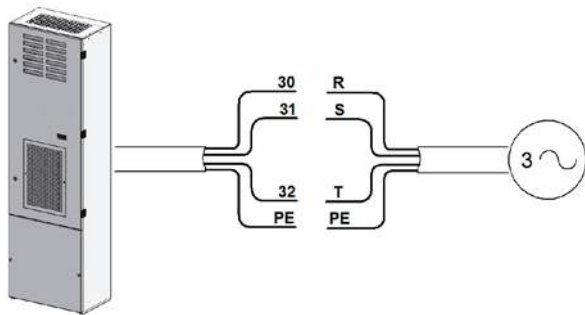

F.13

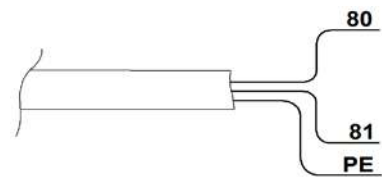

14. TECHNICAL DATA F.14

Characteristics		EMO60M	EMO60N	EMO80M	EMO80N	EMOA0M	EMOA0N
Cooling capacity EN14511 – A35A35	W	5800	6050	7600	7950	9400	9850
Cooling capacity EN14511 – A35A50	W	4350	4530	5700	5930	7000	7350
Power supply	V ~ Hz	400 3~ 50	460 3~ 60	400 3~ 50	460 3~ 60	400 3~ 50	460 3~ 60
Width	mm	600	600	800	800	800	800
Height	mm	2000	2000	2000	2000	2000	2000
Depth	mm	387	387	387	387	387	387
Max. current	A	5,9	6,8	8,1	9,3	9,1	10,3
Inrush current	A	21,7	23,5	30,7	32,5	30,7	32,5
Fuse T	A	8	8	16	16	18	18
Absorbed electric power EN14511 – A35A35	W	2340	2920	3300	4035	3650	4380
Absorbed electric power EN14511 – A35A50	W	3880	4520	4910	5845	5400	6340
Duty cycle	-	100%	100%	100%	100%	100%	100%
Refrigerant	kg	1,8	1,8	2,8	2,8	2,3	2,3
		R407C	R407C	R134a	R134a	R134a	R134a
Cooling circuit max. pressure	bar	27	27	27	27	27	27
External fan air flow	m ³ /h	2900	2900	2900	2900	2900	2900
Enclosure fan air flow	m ³ /h	1450	1450	2900	2900	2900	2900
Internal temperature range	°C	+20 / +45	+20 / +45	+20 / +45	+20 / +45	+20 / +45	+20 / +45
Temperature setting	-	Mechanical thermostat	Mechanical thermostat	Mechanical thermostat	Mechanical thermostat	Mechanical thermostat	Mechanical thermostat
External temperature range	°C	-20 / +50	-20 / +50	-20 / +50	-20 / +50	-20 / +50	-20 / +50
Protection level EN60529 – enclosure side	-	IP54	IP54	IP54	IP54	IP54	IP54
Protection level EN60529 – ambient side	-	IP34	IP34	IP34	IP34	IP34	IP34
Noise level	dB (A)	72	72	75	75	77	77
Weight	kg	150	150	160	160	180	180
Conformity	-	CE – UKCA	CE – UKCA	CE – UKCA	CE – UKCA	CE – UKCA	CE – UKCA

15. PERFORMANCES F.15

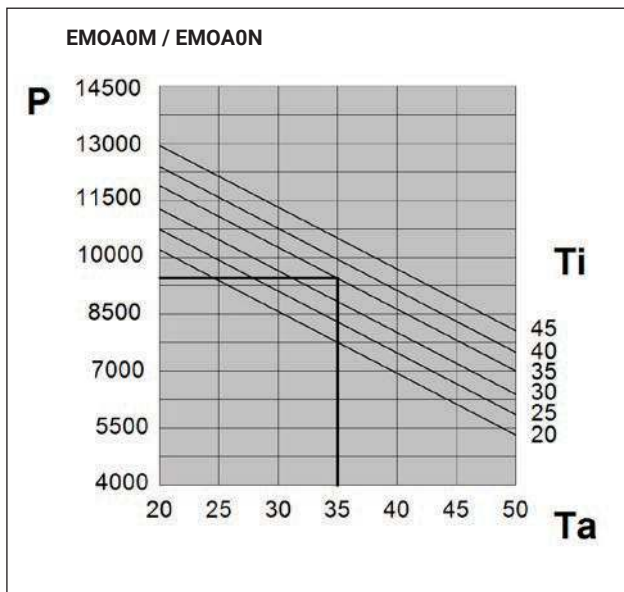
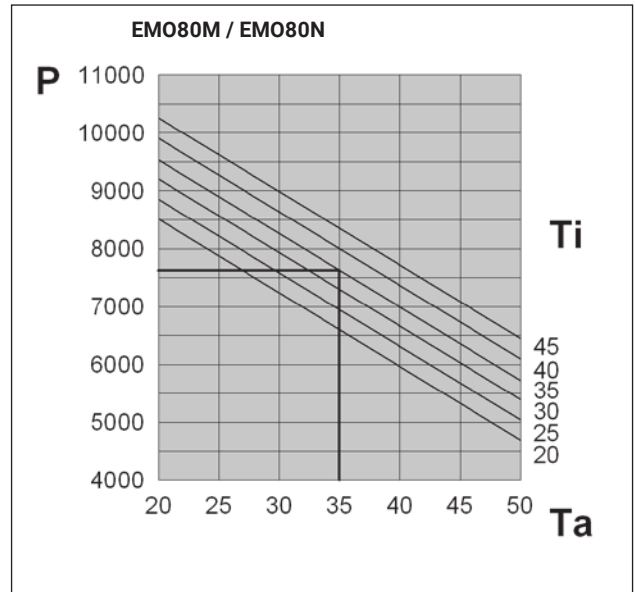
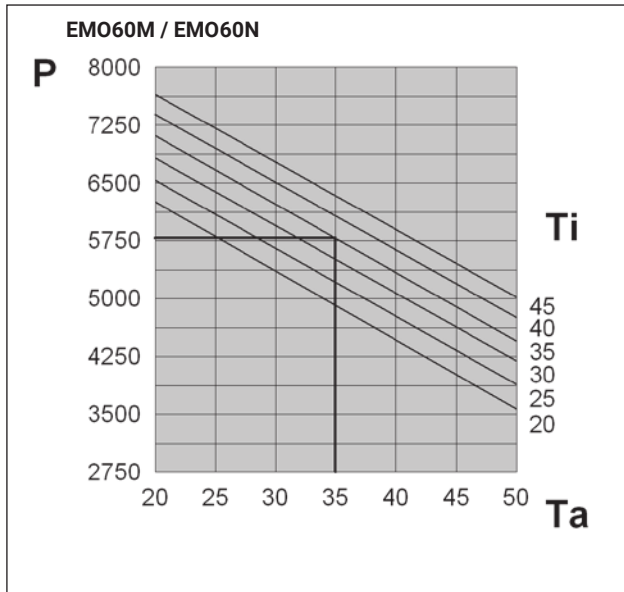

P (W)	Ta (°C)	Ti (°C)
Useful cooling output	Ambient temperature	Enclosure internal temperature

16. DIMENSIONS F.16

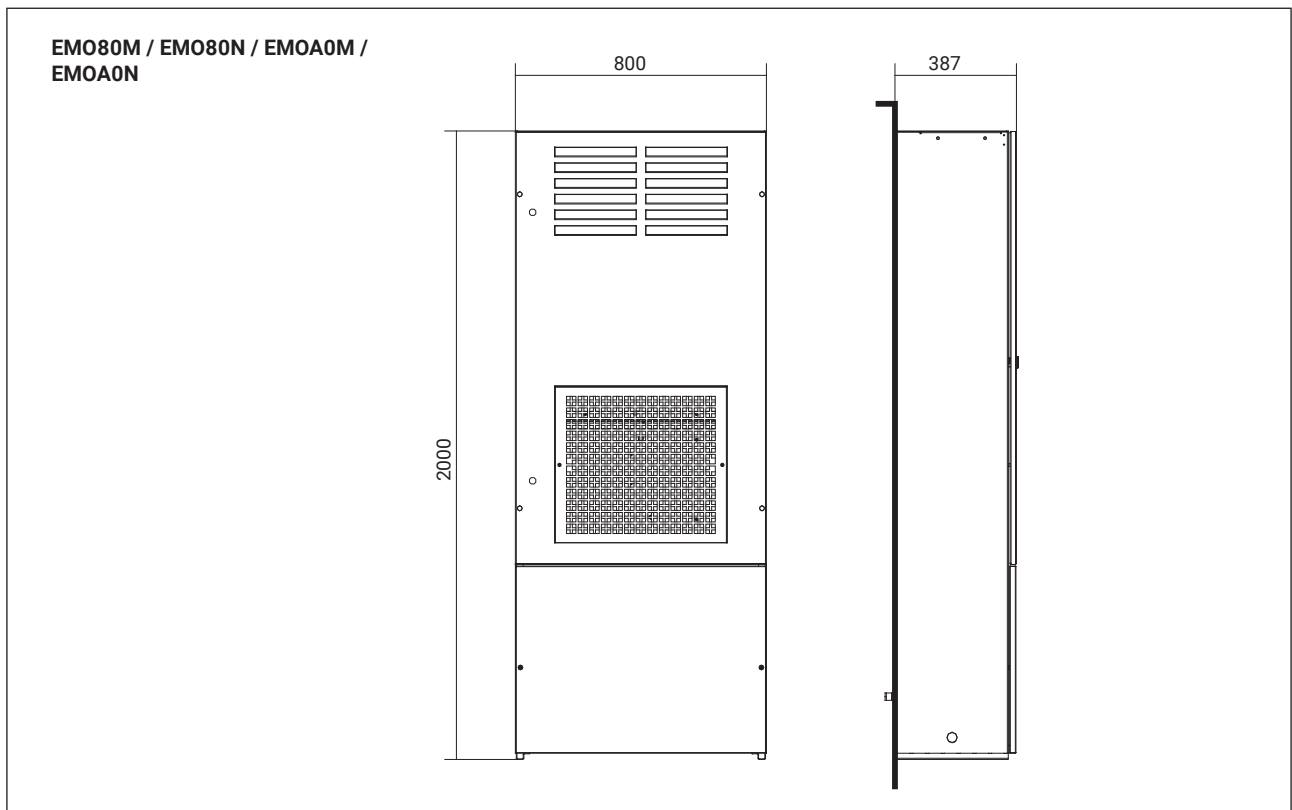
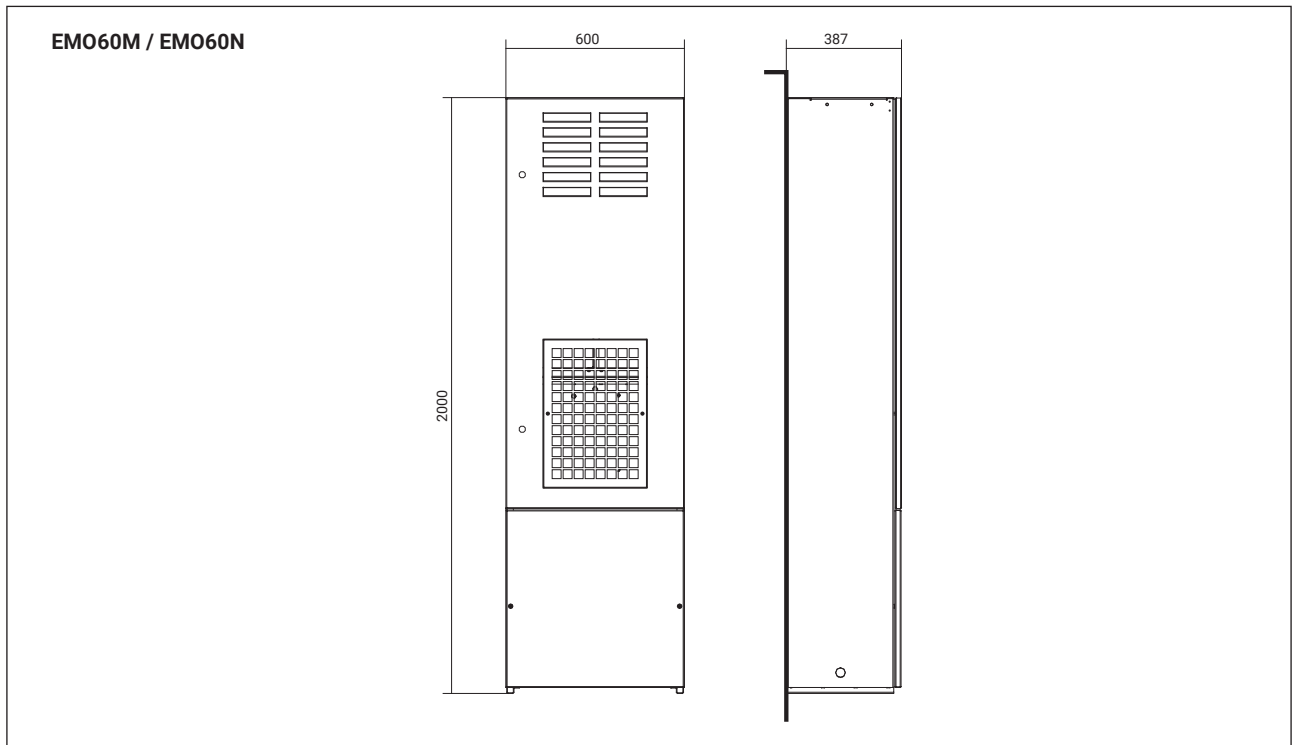

17. SPARE PARTS F.17

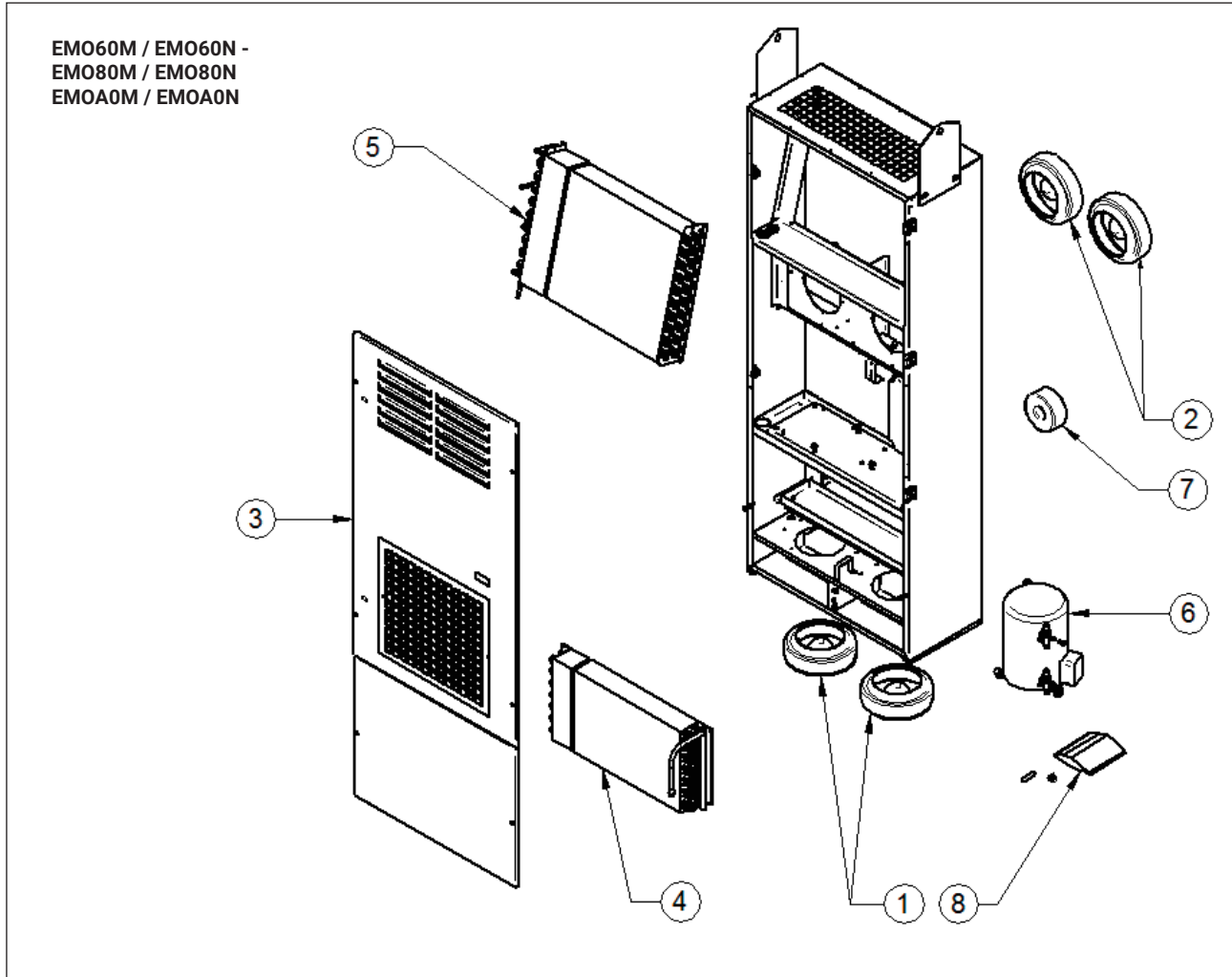

1. Evaporator fan

2. Condenser fan

3. Front structure

4. Evaporator

5. Condenser

6. Compressor

7. Autotransformer

8. Assembly accessory kit

When ordering the following informations are essential: Model, Serial number, Date of production, Requested parts' code

18. GUARANTEE

TEXA INDUSTRIES S.r.l. guarantees its product free from quality defects. It also guarantees for 12 months all the product's components starting from the date of shipment and when they are used in the following conditions:

1. When the temperatures of the panel or enclosure are no higher or lower than those indicated on the rating plate.
2. In circuits or systems that do not require cooling capacities higher than those indicated on the rating plate.
3. On premises where the temperatures are no higher or lower than those indicated on the rating plate.
4. On panels or enclosures with at least a minimum protection level of IP54.
5. When the instructions given in the "operating and maintenance" manual, provided with each single product, are fully complied with.

This guarantee does not cover any damage to the product due to:

- a. using a type and quantity of gas in the cooling circuit different to that indicated on the rating plate.
- b. using the product on unsuitable premises: where there is an acid or corrosive atmosphere.

For each component found to be faulty during the term of the guarantee, the manufacturer will, according to its unquestionable judgement, repair and/or substitute the faulty components free of charge either at its factory or in one of its authorised companies. Any additional expenses incurred for removing, handling and installation if required are not payable by the manufacturer. Any maintenance work needed and requested by the customer care/of his premises, even if it is during the term of the guarantee, will be billed according to the manufacturer rates. The products repaired or substituted in no way modify the time the guarantee starts or ends. The manufacturer can in no way be held liable except for repairing or substituting faulty products and if such products have to be redelivered it will be on a Carriage Forward basis. It is the customer's responsibility to see to the correct earthing, installation and power supply of the product in compliance with current standards. Reference must be made to the current laws in force regarding liability for damage caused by a faulty product, for which manufacturer is insured.

To benefit from the guarantee terms and relative product information it is essential to have the purchase document and the serial number of the product which you will find on the rating plate. The rating plate is printed on plastic and the writing will remain for a long time even on premises and in environments where conditions are particularly bad.

⚠ ATTENTION: the guarantee is automatically invalidated if the product is tampered with in any way.

19. ASSISTANCE SERVICE

Assistance Service For machine malfunctions, technical information or advice on installation, please contact Assistance Service at: TEXA INDUSTRIES S.r.l.

Strada Cà Bruciata, 5 46020 – Pegognaga (MN) - ITALIA

Tel.: 0376 – 554511 - e-mail: texa.service@nVent.com

Before contacting the Manufacturer Assistance Service, ensure you have:

- A. The full machine code number;
- B. The serial number of the machine;

All requests for assistance must be sent to Manufacturer in writing, by email or fax.

⚠ Warning: The equipment can only be returned to Manufacturer on request and after agreement by the Manufacturer itself.

20. NOTES

A series of horizontal dotted lines for taking notes, spanning the width of the page.





North America

service@nVent.com
Tel +1 763 422 2211

Follow prompts for option 1,
then option 2 then option 3

All Other Locations

texa.service@nVent.com
Tel +39 0376 554511



Our powerful portfolio of brands:

CADDY ERICO HOFFMAN ILSCO RAYCHEM SCHROFF