

# Megatiker M3 125 thermal magnetic circuit breakers and MS3 125 trip-free switches

Cat.Nos:

T7303F16/20/25/32/40/50/63/80/100/125-T7304F16/20/25/32/40/50/63/80/100/125  
T7303N16/20/25/32/40/50/63/80/100/125-T7304N16/20/25/32/40/50/63/80/100/125  
T7303H16/20/25/32/40/50/63/80/100/125-T7304H16/20/25/32/40/50/63/80/100/125  
T7303L16/20/25/32/40/50/63/80/100/125-T7304L16/20/25/32/40/50/63/80/100/125  
T7303S125-T7304S125



| CONTENT                             | Page |
|-------------------------------------|------|
| 1. Use .....                        | 1    |
| 2. Range .....                      | 1    |
| 3. Technical characteristics.....   | 1    |
| 4. Installation rules.....          | 3    |
| 5. Dimensions and weight .....      | 4    |
| 6. Connections .....                | 6    |
| 7. Equipments and accessories.....  | 6    |
| 8. Marking .....                    | 8    |
| 9. Curves .....                     | 10   |
| 10. Standards and regulations ..... | 16   |
| 11. Other information .....         | 16   |

## 1. USE

Megatiker range has been developed to give a new solution of protection devices for a more precise approach in power installations in order to offer the correct answer for different project needs.

Megatiker M3 range provides a complete project approach in premium market segment, offering a range completely suitable for high power application with high performance breakers in compact dimensions and at a competitive costs.

## 2. RANGE

### 2.1 Megatiker M3 125 thermal magnetic circuit breaker

| Icu | 36 kA     |           | 50 kA     |           |
|-----|-----------|-----------|-----------|-----------|
|     | 3P        | 4P        | 3P        | 4P        |
| 16  | T7303F16  | T7304F16  | T7303N16  | T7304N16  |
| 20  | T7303F20  | T7304F20  | T7303N20  | T7304N20  |
| 25  | T7303F25  | T7304F25  | T7303N25  | T7304N25  |
| 32  | T7303F32  | T7304F32  | T7303N32  | T7304N32  |
| 40  | T7303F40  | T7304F40  | T7303N40  | T7304N40  |
| 50  | T7303F50  | T7304F50  | T7303N50  | T7304N50  |
| 63  | T7303F63  | T7304F63  | T7303N63  | T7304N63  |
| 80  | T7303F80  | T7304F80  | T7303N80  | T7304N80  |
| 100 | T7303F100 | T7304F100 | T7303N100 | T7304N100 |
| 125 | T7303F125 | T7304F125 | T7303N125 | T7304N125 |

| Icu | 70 kA     |           | 100 kA    |           |
|-----|-----------|-----------|-----------|-----------|
|     | 3P        | 4P        | 3P        | 4P        |
| 16  | T7303H16  | T7304H16  | T7303L16  | T7304L16  |
| 20  | T7303H20  | T7304H20  | T7303L20  | T7304L20  |
| 25  | T7303H25  | T7304H25  | T7303L25  | T7304L25  |
| 32  | T7303H32  | T7304H32  | T7303L32  | T7304L32  |
| 40  | T7303H40  | T7304H40  | T7303L40  | T7304L40  |
| 50  | T7303H50  | T7304H50  | T7303L50  | T7304L50  |
| 63  | T7303H63  | T7304H63  | T7303L63  | T7304L63  |
| 80  | T7303H80  | T7304H80  | T7303L80  | T7304L80  |
| 100 | T7303H100 | T7304H100 | T7303L100 | T7304L100 |
| 125 | T7303H125 | T7304H125 | T7303L125 | T7304L125 |

### 2.2 MS3 125 trip-free switch

| In (A) | 3P        | 4P        |
|--------|-----------|-----------|
| 125    | T7303S125 | T7304S125 |

### 2.3 Composition

- Megatiker M3 125 thermal magnetic is supplied with:
- fixing screws (2 for 3P, and 4 for 4P)
- screws for connections (6 for 3P, and 8 for 4P)
- phase insulators (2 for 3P, and 3 for 4P)

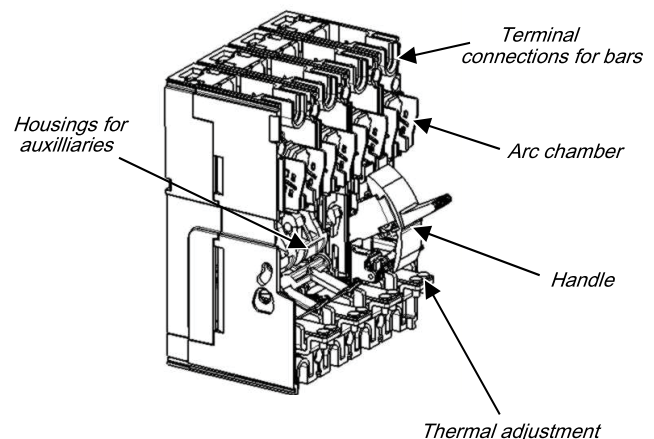

## 3. TECHNICAL CHARACTERISTICS

### 3.1 Electrical characteristics

#### Megatiker M3 125 thermal magnetic circuit breakers

|                                       |   |
|---------------------------------------|---|
| Rated current                         | 16 A - 20 A - 25 A - 32 A<br>40 A - 50 A - 63 A - 80 A<br>100 A - 125 A |
| Poles                                 | 3P - 4P   |
| Pole pitch                            | 25 mm   |
| Rated insulation voltage (50/60Hz) Ui | 800 V   |
| Rated operating voltage (50/60Hz) Ue  | 690 V   |
| Rated impulse withstand current Uimp  | 8 kV  |
| Rated frequency                       | 50 Hz - 60 Hz   |
| Reference ambient temperature         | 40 °C - 50 °C   |

# Megatiker M3 125 thermal magnetic circuit breakers and MS3 125 trip-free switches

Cat.Nos:  
T7303F16/20/25/32/40/50/63/80/100/125-T7304F16/20/25/32/40/50/63/80/100/125  
T7303N16/20/25/32/40/50/63/80/100/125-T7304N16/20/25/32/40/50/63/80/100/125  
T7303H16/20/25/32/40/50/63/80/100/125-T7304H16/20/25/32/40/50/63/80/100/125  
T7303L16/20/25/32/40/50/63/80/100/125-T7304L16/20/25/32/40/50/63/80/100/125  
T7303S125-T7304S125

## 3. TECHNICAL CHARACTERISTICS (continued)

### 3.1 Electrical characteristics (continued)

| Megatiker M3 125 thermal magnetic circuit breakers |   |
|--|---|
| Operating temperature                              | -25 °C to 70 °C   |
| Electrical endurance at In (cycles)                | 8000  |
| Utilization category                               | A   |
| Suitable for isolation                             | Yes   |
| Type of protection                                 | Thermal-magnetic  |
| Thermal adjustment Ir                              | 0.8 - 0.9 - 1 x In  |
| Magnetic adjustment Ii (A)                         | 400 A up to In = 40 A (not adjustable)<br>10 x In up to In = 125 A (not adjustable) |
| Neutral protection for 4P (%Ith of phase pole)     | 100   |
| Reverse feed                                       | Yes   |

### Megatiker MS3 125 trip-free switches

|   |                 |
|---|-----------------|
| Uninterrupted nominal current Ie        | 125 A           |
| Short-time resistive current Icw for 1s | 1.5 kA          |
| Rated short-circuit making capacity Icm | 2.5 kA          |
| Rated insulation voltage Ui             | 800 V~          |
| Maximum rated operating voltage Ue      | 690 V~          |
| Rated impulse withstand voltage Uimp    | 8 kV            |
| Utilisation category                    | AC23A           |
| Suitable for isolation                  | Yes             |
| Rated frequency (Hz)                    | 50 Hz - 60 Hz   |
| Operating temperature                   | -25 °C to 70 °C |
| Electrical endurance at In (cycles)     | 8000            |
| Reverse feed                            | Yes             |

The maximum temperature allowed on power terminals is 125 °C (absolute). For details, see IEC 60947-1 and 60947-2.

### Trip-free switch category (for use in DC)

|        | 1P*  | 2P in series* |       | 3P in series* | 4P in series* |
|--------|------|---------------|-------|---------------|---------------|
| In (A) | 60 V | 110 V         | 250 V | 500 V         | 750 V         |
| 125    | DC23 |               |       |               |               |

\*See page 6 for Connection modality of the DC trip-free switches

### Breaking capacity (3P and 4P)

| IEC 60947-2                                   | Breaking capacity (kA) & Ics |       |       |       |        |
|---|------------------------------|-------|-------|-------|--------|
|   | Ue                           | Icu   |       |       |        |
|   |                              | 36 kA | 50 kA | 70 kA | 100 kA |
| 240 V~  | 70                           | 90    | 100   | 150   |        |
| 415 V~  | 36                           | 50    | 70    | 100   |        |
| 500 V~  | 12                           | 16    | 20    | 25    |        |
| 690 V~  | 5                            | 6     | 10    | 12    |        |
| 250 V=  | 10                           |       |       |       |        |
| Ics (% Icu)                                   | 100                          |       |       |       |        |
| Rated making capacity under short circuit Icm |                              |       |       |       |        |
| Icm (kA) at 415 V                             | 76.5                         | 105   | 154   | 220   |        |

### Breaking capacity in DC (kA) (estimated values)

| Icu   | In (A)   | 1P*  | 2P in series * |       | 3P in series * |       |       |       |
|-------|----------|------|----------------|-------|----------------|-------|-------|-------|
|       |          | 60 V | 60 V           | 110 V | 250 V          | 110 V | 250 V | 500 V |
| 36 kA | 16 ÷ 125 | 35   | 36             | 35    | 10             | 35    | 20    | 10    |
| 50 kA |          |      | 50             |       |                |       |       |       |

\*See page 6 for Connection modality of the DC breaker.

DC breaking capacity in the table respect the standards. The positive tolerance is between 0 % to 5 % of voltage status

### Rated current (In) at 40 °C / 50 °C

| In (A) | Phases limit trip current |        | Magnetic (Ii) |      |      |
|--------|---------------------------|--------|---------------|------|------|
|        | Thermal (Ir)              |        | Min.          | Max. |      |
| 16     | 0.8 x In                  | 1 x In | 400           |      |      |
| 20     | 13                        | 16     |               |      |      |
| 25     | 16                        | 20     |               |      |      |
| 32     | 20                        | 25     |               |      |      |
| 40     | 26                        | 32     |               |      |      |
| 50     | 32                        | 40     |               |      |      |
| 63     | 40                        | 50     |               |      | 500  |
| 80     | 51                        | 63     |               |      | 630  |
| 100    | 64                        | 80     |               |      | 800  |
| 125    | 80                        | 100    |               |      | 1000 |
|        | 100                       | 125    | 1250          |      |      |

### 3.2 Mechanical characteristics

Mechanical endurance (cycles): 20000

### Load operations

|                   | Force on handle (N) |
|-------------------|---------------------|
| Opening operation | 40                  |
| Closing operation | 40                  |
| Restore operation | 53                  |

### 3.3 Electrodynamic forces

The table below shows an indication of suggested distances to keep between the breaker and the first fixing point of the conductor and bars in order to reduce the effects of the electrodynamic stresses that may be created during a short circuit. In the realization of anchorage system it is recommend the use of isolators suitable for the type of conductor used and the operating voltage.

| Icc (kA) | Maximum distance (mm) |
|----------|-----------------------|
| 36       | 350                   |
| 50       | 300                   |
| 70       | 250                   |
| 100      | 200                   |

According to conductor type and bar system (except BTicino bar kits), the choice of the distance to keep is to be calibrated by the installer. Also, the installer must take into account the weight of the conductors so that it does not affect the electrical junction between the conductor itself and the connection point.

# Megatiker M3 125 thermal magnetic circuit breakers and MS3 125 trip-free switches

**Cat.Nos:**  
T7303F16/20/25/32/40/50/63/80/100/125-T7304F16/20/25/32/40/50/63/80/100/125  
T7303N16/20/25/32/40/50/63/80/100/125-T7304N16/20/25/32/40/50/63/80/100/125  
T7303H16/20/25/32/40/50/63/80/100/125-T7304H16/20/25/32/40/50/63/80/100/125  
T7303L16/20/25/32/40/50/63/80/100/125-T7304L16/20/25/32/40/50/63/80/100/125  
T7303S125-T7304S125

## 3. TECHNICAL CHARACTERISTICS (continued)

### 3.4 Power losses per pole under In (W)

| Circuit breakers (Icu ≤ 50 kA)      |      |      |      |      |      |      |      |      |       |       |
|-------------------------------------|------|------|------|------|------|------|------|------|-------|-------|
| In (A)                              | 16   | 20   | 25   | 32   | 40   | 50   | 63   | 80   | 100   | 125   |
| <b>Lugs</b>                         | 3.46 | 4.80 | 7.50 | 2.92 | 4.32 | 6.75 | 6.37 | 6.02 | 9.40  | 9.69  |
| <b>Cage terminals</b>               | 3.47 | 4.82 | 7.53 | 2.97 | 4.40 | 6.88 | 6.58 | 6.35 | 9.93  | 10.51 |
| <b>High capacity cage terminals</b> | 3.47 | 4.82 | 7.54 | 2.98 | 4.42 | 6.91 | 6.62 | 6.41 | 10.02 | 10.66 |
| <b>Spreaders</b>                    | 3.47 | 4.82 | 7.54 | 2.98 | 4.42 | 6.91 | 6.62 | 6.41 | 10.02 | 10.66 |
| <b>Rear terminals</b>               | 3.47 | 4.82 | 7.54 | 2.98 | 4.42 | 6.91 | 6.62 | 6.41 | 10.02 | 10.66 |
| <b>Plug-in version</b>              | 3.58 | 5.00 | 7.81 | 3.43 | 5.12 | 8.35 | 8.35 | 9.22 | 14.40 | 17.50 |

| Circuit breakers (Icu > 50 kA)      |      |      |      |      |      |      |      |       |       |       |
|-------------------------------------|------|------|------|------|------|------|------|-------|-------|-------|
| In (A)                              | 16   | 20   | 25   | 32   | 40   | 50   | 63   | 80    | 100   | 125   |
| <b>Lugs</b>                         | 3.51 | 4.89 | 7.64 | 3.15 | 4.69 | 7.33 | 7.28 | 7.49  | 11.70 | 13.28 |
| <b>Cage terminals</b>               | 3.53 | 4.92 | 7.69 | 3.23 | 4.80 | 7.51 | 7.57 | 7.95  | 12.42 | 14.41 |
| <b>High capacity cage terminals</b> | 3.54 | 4.93 | 7.70 | 3.24 | 4.82 | 7.54 | 7.62 | 8.03  | 12.55 | 14.61 |
| <b>Spreaders</b>                    | 3.54 | 4.93 | 7.70 | 3.24 | 4.82 | 7.54 | 7.62 | 8.03  | 12.55 | 14.61 |
| <b>Rear terminals</b>               | 3.54 | 4.93 | 7.70 | 3.24 | 4.82 | 7.54 | 7.62 | 8.03  | 12.55 | 14.61 |
| <b>Plug-in version</b>              | 3.64 | 5.09 | 7.96 | 3.67 | 5.49 | 8.58 | 9.27 | 10.69 | 16.70 | 21.09 |

Note: power losses in the table above are referred and measured as described in the standard IEC 60947-2 (Annex G) for circuit-breakers. Values in the table are referred to a single phase.

| Trip-free switch                    |       |
|-------------------------------------|-------|
| In (A)                              | 125   |
| <b>Lugs</b>                         | 7.81  |
| <b>Cage terminals</b>               | 8.48  |
| <b>High capacity cage terminals</b> | 8.59  |
| <b>Spreaders</b>                    | 8.59  |
| <b>Rear terminals</b>               | 8.59  |
| <b>Plug-in version</b>              | 15.63 |

Note: power loss in the table above are referred and measured as described in the standard IEC 60947-3 for trip-free switches. Values in the table are referred to a single phase.

## 4. INSTALLATION RULES

According to IEC/EN 60947-1.

### Temperature deratings

Rated current and his adjustment has to be considered relating to a rise or fall of ambient temperature and to a different version or installation conditions. The table below indicates the maximum long-time (LT) protection setting depending on the ambient temperature.

| Temperature Ta (°C) |     |     |     |     |     |     |     |     |     |     |     |
|---------------------|-----|-----|-----|-----|-----|-----|-----|-----|-----|-----|-----|
| In (A)              | -20 | -10 | -5  | 0   | 10  | 20  | 30  | 40  | 50  | 60  | 70  |
| <b>16</b>           | 20  | 20  | 19  | 19  | 18  | 17  | 17  | 16  | 16  | 15  | 14  |
| <b>20</b>           | 25  | 24  | 24  | 23  | 23  | 21  | 21  | 20  | 20  | 18  | 17  |
| <b>25</b>           | 31  | 30  | 30  | 29  | 28  | 27  | 26  | 25  | 25  | 23  | 22  |
| <b>32</b>           | 40  | 39  | 38  | 37  | 36  | 35  | 33  | 32  | 32  | 29  | 28  |
| <b>40</b>           | 50  | 49  | 48  | 47  | 45  | 43  | 42  | 40  | 40  | 37  | 35  |
| <b>50</b>           | 62  | 61  | 59  | 58  | 56  | 54  | 52  | 50  | 50  | 45  | 43  |
| <b>63</b>           | 79  | 77  | 75  | 74  | 71  | 68  | 65  | 63  | 63  | 57  | 54  |
| <b>80</b>           | 100 | 97  | 95  | 93  | 90  | 86  | 83  | 80  | 80  | 73  | 69  |
| <b>100</b>          | 125 | 121 | 119 | 117 | 112 | 108 | 104 | 100 | 100 | 91  | 86  |
| <b>125</b>          | 157 | 151 | 148 | 146 | 140 | 135 | 130 | 125 | 125 | 114 | 108 |

For derating temperature with other configurations, see table below.

# Megatiker M3 125 thermal magnetic circuit breakers and MS3 125 trip-free switches

**Cat.Nos:**  
 T7303F16/20/25/32/40/50/63/80/100/125-T7304F16/20/25/32/40/50/63/80/100/125  
 T7303N16/20/25/32/40/50/63/80/100/125-T7304N16/20/25/32/40/50/63/80/100/125  
 T7303H16/20/25/32/40/50/63/80/100/125-T7304H16/20/25/32/40/50/63/80/100/125  
 T7303L16/20/25/32/40/50/63/80/100/125-T7304L16/20/25/32/40/50/63/80/100/125  
 T7303S125-T7304S125

## 4. INSTALLATION RULES (continued)

| Ambient temperature                  | 30 °C                |                                 | 40 °C                |                                 | 50 °C                |                                 | 60 °C                |                                 | 70 °C                |                                 |
|--------------------------------------|----------------------|---------------------------------|----------------------|---------------------------------|----------------------|---------------------------------|----------------------|---------------------------------|----------------------|---------------------------------|
|                                      | I <sub>max</sub> (A) | I <sub>r</sub> / I <sub>n</sub> | I <sub>max</sub> (A) | I <sub>r</sub> / I <sub>n</sub> | I <sub>max</sub> (A) | I <sub>r</sub> / I <sub>n</sub> | I <sub>max</sub> (A) | I <sub>r</sub> / I <sub>n</sub> | I <sub>max</sub> (A) | I <sub>r</sub> / I <sub>n</sub> |
| Cage terminals, flexible/rigid cable | 130                  | 1.04                            | 125                  | 1                               | 125                  | 1                               | 114                  | 0.91                            | 108                  | 0.86                            |
| Lugs, flexible/rigid cable           |                      |                                 |                      |                                 |                      |                                 |                      |                                 |                      |                                 |
| Spreaders, flexible/rigid cable      |                      |                                 |                      |                                 |                      |                                 |                      |                                 |                      |                                 |
| Rear terminals, flexible cable       |                      |                                 |                      |                                 |                      |                                 |                      |                                 |                      |                                 |

For further technical information, please contact BTicino technical support.

**Climatic conditions:** according to IEC/EN 60947-1 Annex Q, Cat. F subject to temperature, humidity, vibration, shock and salt mist.

**Electromagnetic disturbances (EMC):** for Megatiker M3 125 circuit breakers, according to IEC/EN 60947-2 Annex F.

**Pollution degree:** for Megatiker M3 125 circuit breakers, degree 3, according to IEC/EN 60947-2.

### Altitude

Altitude derating for Megatiker M3 circuit breakers and switch disconnectors

| Altitude (m)  | 2000               | 3000                  | 4000                  | 5000                 |
|---|--------------------|-----------------------|-----------------------|----------------------|
| U <sub>e</sub> (V)                                  | 690                | 590                   | 520                   | 460                  |
| I <sub>n</sub> (A) (T <sub>a</sub> = 40 °C / 50 °C) | 1 x I <sub>n</sub> | 0.98 x I <sub>n</sub> | 0.93 x I <sub>n</sub> | 0.9 x I <sub>n</sub> |

## 5. DIMENSIONS AND WEIGHT

### 5.1 Dimensions (mm)

3P (W x H x D): 75 x 135 x 86

4P (W x H x D): 100 x 135 x 86

#### Device without accessories

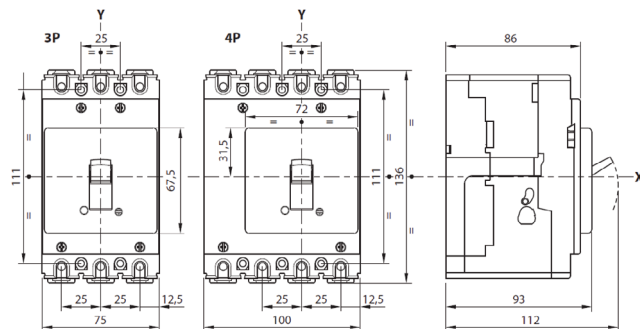

#### 4P

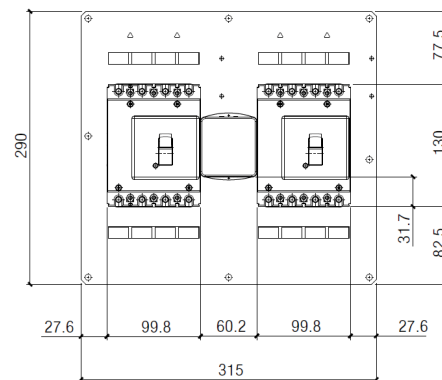

For rear plate interlock dimension, see relative instruction sheet.

#### With interlock 3P

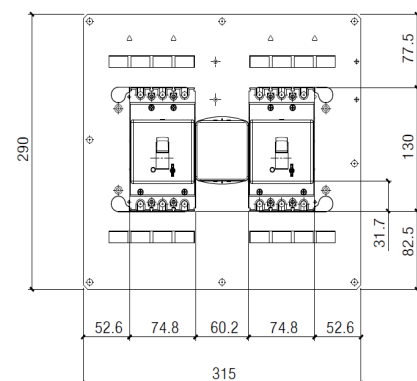

#### With direct rotary handle

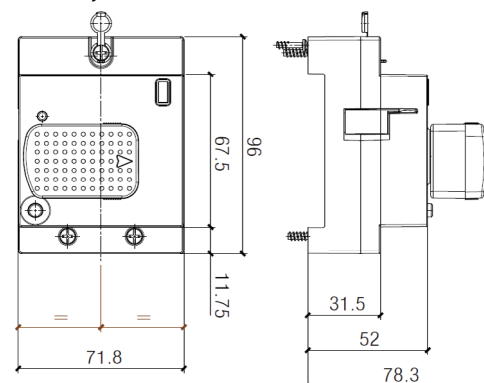

# Megatiker M3 125 thermal magnetic circuit breakers and MS3 125 trip-free switches

Cat.Nos:  
 T7303F16/20/25/32/40/50/63/80/100/125-T7304F16/20/25/32/40/50/63/80/100/125  
 T7303N16/20/25/32/40/50/63/80/100/125-T7304N16/20/25/32/40/50/63/80/100/125  
 T7303H16/20/25/32/40/50/63/80/100/125-T7304H16/20/25/32/40/50/63/80/100/125  
 T7303L16/20/25/32/40/50/63/80/100/125-T7304L16/20/25/32/40/50/63/80/100/125  
 T7303S125-T7304S125

## 5. DIMENSIONS AND WEIGHT (continued)

### 5.1 Dimensions (continued)

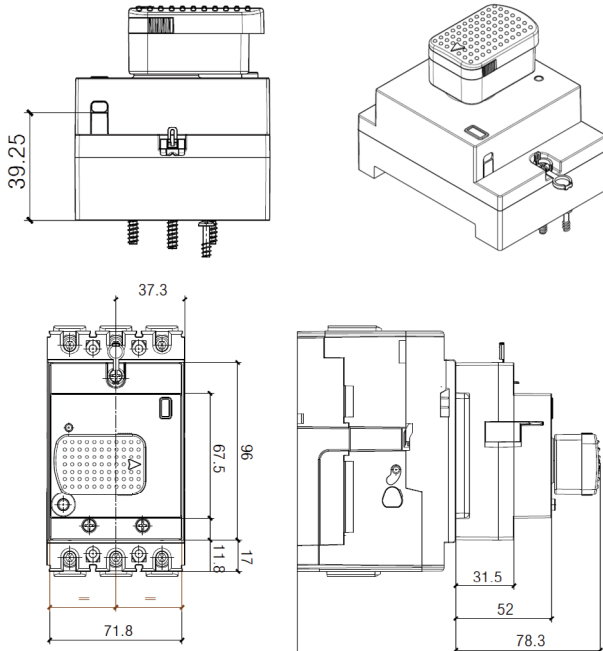

### With vari-depth rotary handle

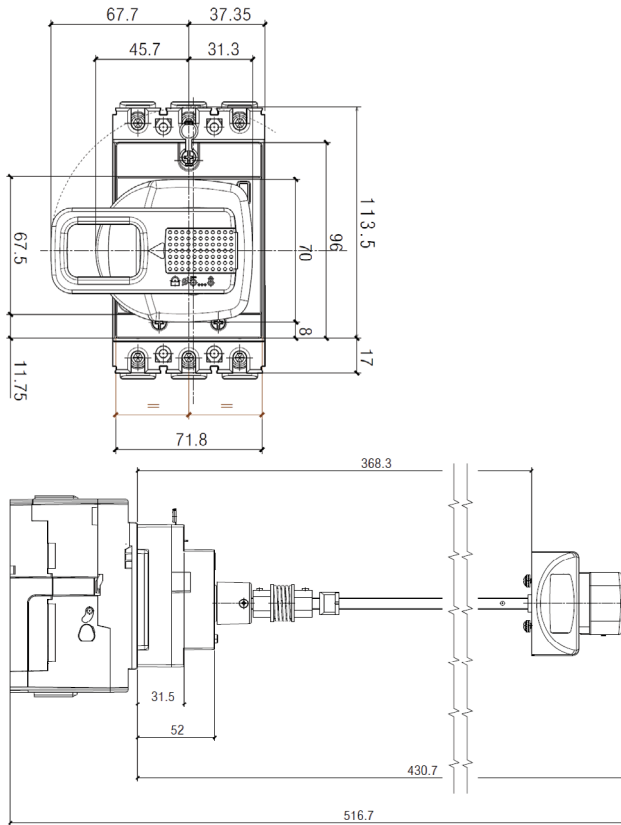

### With sealable terminal shield

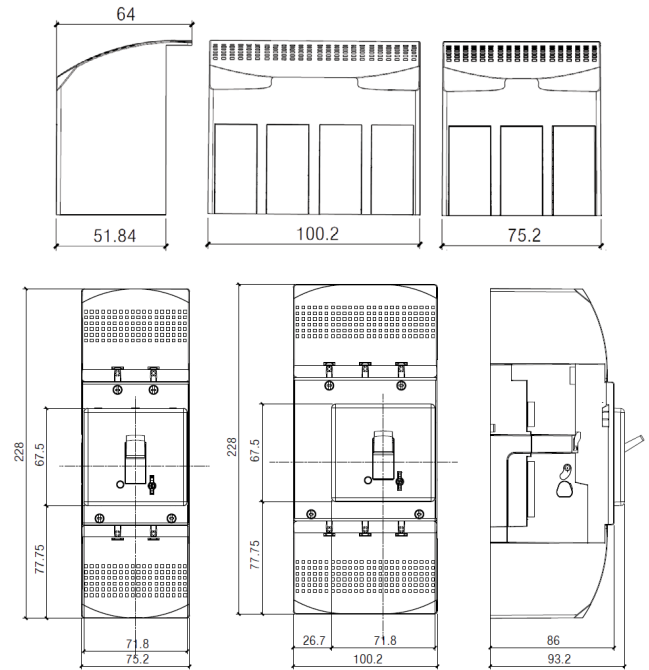

### With spreaders

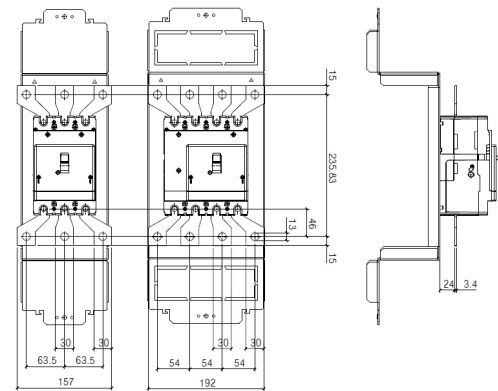

### With rear terminal

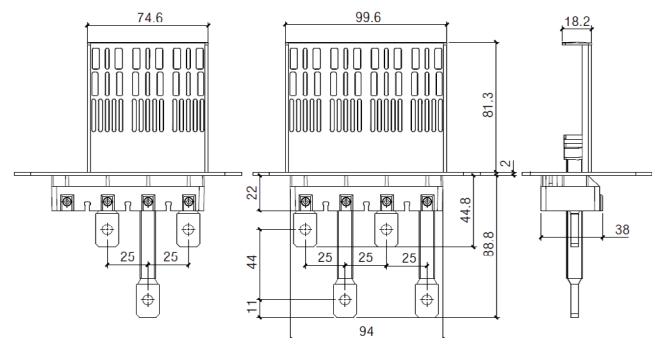

# Megatiker M3 125 thermal magnetic circuit breakers and MS3 125 trip-free switches

**Cat.Nos:**  
T7303F16/20/25/32/40/50/63/80/100/125-T7304F16/20/25/32/40/50/63/80/100/125  
T7303N16/20/25/32/40/50/63/80/100/125-T7304N16/20/25/32/40/50/63/80/100/125  
T7303H16/20/25/32/40/50/63/80/100/125-T7304H16/20/25/32/40/50/63/80/100/125  
T7303L16/20/25/32/40/50/63/80/100/125-T7304L16/20/25/32/40/50/63/80/100/125  
T7303S125-T7304S125

## 5. DIMENSIONS AND WEIGHT (continued)

### 5.1 Dimensions (continued)

With rear terminal (continued)

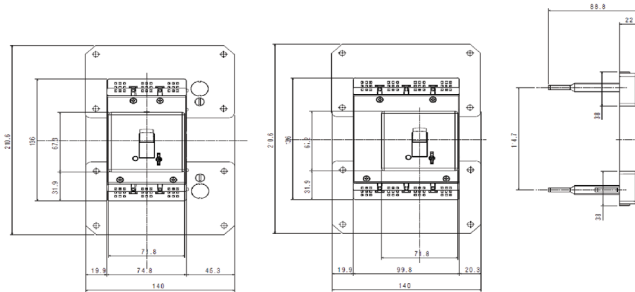

### 5.2 Weight

| Configuration                    | Weight (kg) |       |
|----------------------------------|-------------|-------|
|                                  | 3P          | 4P    |
| Circuit breaker/trip-free switch | 0.95        | 1.2   |
| Direct rotary handle*            | 0.18        |       |
| Vari depth rotary handle*        | 0.55        |       |
| Interlock*                       | 0.35        |       |
| Spreader*                        | 0.135       | 0.175 |

\* to add to device weight

## 6. CONNECTIONS

Possible way of assembly on plate:

- vertical
- horizontal

It is possible to use:

- busbars;
- cables lugs;
- spreaders;
- cage terminals;

to ensure the circuit breaker's connection.

For detailed mounting procedures, see instruction sheet.

### DC connections modality for breakers

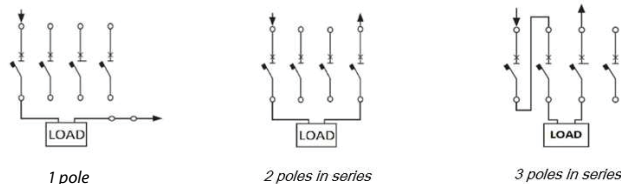

### DC connections modality for trip-free switches (polarity can be inverted)

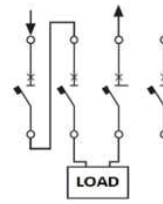
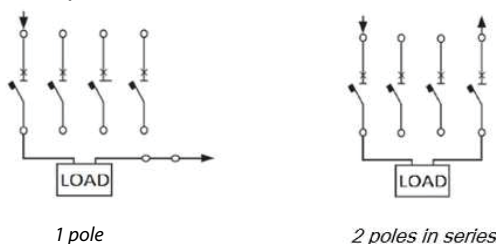

3 poles in series

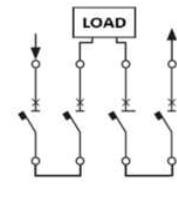

4 poles in series

Applied to DC breaker/switch networks insulated from the ground

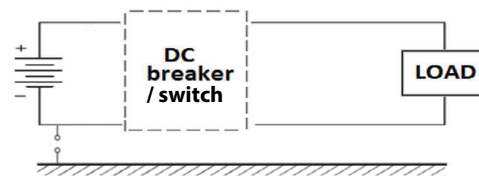

## 7. EQUIPMENTS AND ACCESSORIES

### 7.1 Releases

There are 3 types of releases (suitable for Megatiker M3 125/160/250, M1 and M2):

#### Shunt releases (ST)

|                            |               |
|----------------------------|---------------|
| 12 V $\sim$ /=             | Cat.No M7S012 |
| 24 V $\sim$ /=             | Cat.No M7S024 |
| 48 V $\sim$ /=             | Cat.No M7S048 |
| 110 $\div$ 130 V $\sim$    | Cat.No M7S110 |
| 220 $\div$ 277 V $\sim$    | Cat.No M7S230 |
| 380 $\div$ 480 V $\sim$    | Cat.No M7S415 |
| Maximum power = 400 VA / W |               |

#### Undervoltage releases (UVR)

|                            |               |
|----------------------------|---------------|
| 12 V $\sim$ /=             | Cat.No M7U012 |
| 24 V $\sim$ /=             | Cat.No M7U024 |
| 48 V $\sim$ /=             | Cat.No M7U048 |
| 110 $\div$ 130 V $\sim$ /= | Cat.No M7U110 |
| 220 $\div$ 240 V $\sim$    | Cat.No M7U230 |
| 277 V $\sim$               | Cat.No M7U277 |
| 380 $\div$ 415 V $\sim$    | Cat.No M7U415 |
| 440 $\div$ 480 V $\sim$    | Cat.No M7U480 |

Maximum power = 4 VA

Circuit breaker opening time < 50 ms

Undervoltage releases can be used on Megatiker M3 125/160/250 starting from batch 19W15.

#### Time-lag undervoltage releases (800 ms)

|  |                    |
|--|--------------------|
| - Release                              | Cat.No M7UEM       |
| to be equipped with a time-lag module: |                    |
| - 230 V $\sim$                         | Cat.No M7000MR/230 |
| - 400 V $\sim$                         | Cat.No M7000MR/400 |

# Megatiker M3 125 thermal magnetic circuit breakers and MS3 125 trip-free switches

**Cat.Nos:**  
T7303F16/20/25/32/40/50/63/80/100/125-T7304F16/20/25/32/40/50/63/80/100/125  
T7303N16/20/25/32/40/50/63/80/100/125-T7304N16/20/25/32/40/50/63/80/100/125  
T7303H16/20/25/32/40/50/63/80/100/125-T7304H16/20/25/32/40/50/63/80/100/125  
T7303L16/20/25/32/40/50/63/80/100/125-T7304L16/20/25/32/40/50/63/80/100/125  
T7303S125-T7304S125

## 7. EQUIPMENTS AND ACCESSORIES (continued)

### ■ 7.2 Auxiliary contacts

It is used to show the state of the contacts or opening of the Megatiker M3 125/160/250 on a fault.

Standard auxiliary contact (OC) / Fault signal (CTR) Cat.No 4 210 11

| Rated voltage (Vn)     | Intensity (A) |
|------------------------|---------------|
| 24 V <sub>~</sub>      | 5             |
| 48 V <sub>~</sub>      | 1.7           |
| 110 V <sub>~</sub>     | 0.5           |
| 230 V <sub>~</sub>     | 0.25          |
| 110 V <sub>~</sub>     | 4             |
| 230/250 V <sub>~</sub> | 3             |

Configurations

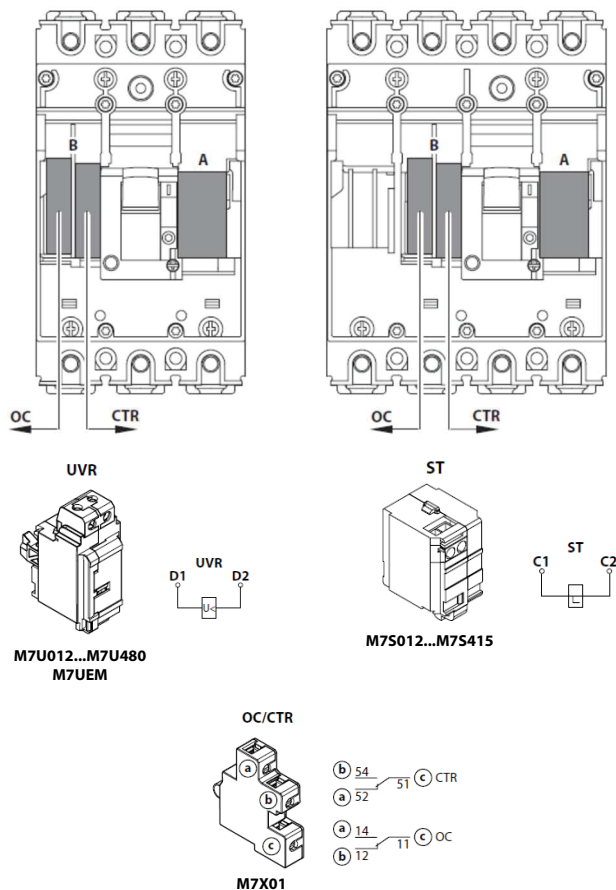

In the space A, it is possible to insert 1 shunt release, or alternatively 1 undervoltage release. The space B can only receive a standard auxiliary contact (OC) or a fault signal (CTR).

To get more information on auxiliary mounting procedures, please refer to product instruction sheet.

### ■ 7.3 Universal keylocks

These keylocks must be used on rotaty handle, that is the only accessory that can be locked on Megatiker M3 125.

For each of these, the specific accessory (indicated in the specific section of this data sheet) must be added in order to get the complete locking kits for the specific application.

- 1 lock + 1 flat key with random mapping Cat.No M7K01
- 1 lock + 1 flat key with fixed mapping (EL43525) Cat.No M7K02
- 1 lock + 1 flat key with fixed mapping (EL43363) Cat.No M7K03
- 1 lock + 1 star key with random mapping Cat.No M7K04

### ■ 7.4 Rotary handles

There are 2 types of suited rotary handles:

#### Direct on Megatiker

- Standard (black) Cat.No M7R20
- For emergency use (red / yellow) Cat.No M7R21

#### Vari-depth handle IP55 (with auxiliary option)

- Standard (black) Cat.No M7R22
- For emergency use (red / yellow) Cat.No M7R23

#### Locking accessories for rotary handle with auxiliary option

- Key lock accessory for vari-depth rotary handle, also compatible with Megatiker M3 160/250 thermal magnetic. Cat.No M7R31

Cat.No M7R31 must be used with universal keylocks to get the complete locking kit for rotary handle.

### ■ 7.5 Mechanical accessories

- Padlock (for locking in "OPEN" position) Cat.No M7X02
- Cat.No M7X02 is compatible with Megatiker M1/M2 and M3 250

#### Sealable terminal shields

- Set of 2 (for 3P) Cat.No M7C20
- Set of 3 (for 4P) Cat.No M7C21

#### Insulated shields

- Set of 3 (for 4P) Cat.No M7F01
- Set of 3 (for 4P) Cat.No M7F02

(Cat.Nos M7F01/02 are also compatible with Megatiker M3 250)

### ■ 7.6 Connection accessories

#### Cage terminals

- Set of 3 standard terminals for 1x95 mm<sup>2</sup> max (rigid) or 1x70 mm<sup>2</sup> max (flexible) Cu/Al cables (for Al cables I<sub>n</sub> max 80A) Cat.No M7X50

- Set of 4 standard terminals for 1x95 mm<sup>2</sup> max (rigid) or 1x70 mm<sup>2</sup> max (flexible) Cu/Al cables (for Al cables I<sub>n</sub> max 80A) Cat.No M7X51

- Set of 3 high capacity terminals for 1x 120 mm<sup>2</sup> max (rigid) or 1x95 mm<sup>2</sup> max (flexible) Cu/Al cables Cat.No M7X52

- Set of 4 high capacity terminals for 1x 120 mm<sup>2</sup> max (rigid) or 1x95 mm<sup>2</sup> max (flexible) Cu/Al cables Cat.No M7X53

# Megatiker M3 125 thermal magnetic circuit breakers and MS3 125 trip-free switches

Cat.Nos:

T7303F16/20/25/32/40/50/63/80/100/125-T7304F16/20/25/32/40/50/63/80/100/125  
T7303N16/20/25/32/40/50/63/80/100/125-T7304N16/20/25/32/40/50/63/80/100/125  
T7303H16/20/25/32/40/50/63/80/100/125-T7304H16/20/25/32/40/50/63/80/100/125  
T7303L16/20/25/32/40/50/63/80/100/125-T7304L16/20/25/32/40/50/63/80/100/125  
T7303S125-T7304S125

## 7. EQUIPMENTS AND ACCESSORIES (continued)

### 7.6 Connection accessories (continued)

#### Cage terminal use specifications

|  | Cable standard suggested cross-section (mm <sup>2</sup> )* |     |    |
|--|--|-----|----|
|  | In (A)   | Cu  | Al |
| Standard cage terminals Cat.Nos M7X50 / M7X51      | 16   | 2.5 | 4  |
|  | 20   | 2.5 | 4  |
|  | 25   | 4   | 6  |
|  | 32   | 6   | 10 |
|  | 40   | 10  | 16 |
|  | 50   | 10  | 16 |
|  | 63   | 16  | 25 |
|  | 80   | 25  | 35 |
|  | 100  | 35  | -  |
| High capacity cage terminals Cat.Nos M7X52 / M7X53 | 80   | 25  | 35 |
|  | 100  | 35  | 50 |
|  | 125  | 50  | 70 |

\* The suggested cross-section are in compliance with standard IEC 60947-1 (ed.6 2020/04) and IEC 60947-2 (ed.5.1 2019/07)

#### Dimensions limits of cable for cage terminals

| Standard cage terminals Cat.Nos M7X50 / M7X51      | Min. cross-section (mm <sup>2</sup> ) |       | Max. cross-section (mm <sup>2</sup> ) |       |
|--|---------------------------------------|-------|---------------------------------------|-------|
|  | Flexible                              | Rigid | Flexible                              | Rigid |
|  | 2.5                                   | 4     | 70                                    | 95    |
| High capacity cage terminals Cat.Nos M7X52 / M7X53 | Min. cross-section (mm <sup>2</sup> ) |       | Max. cross-section (mm <sup>2</sup> ) |       |
|  | Flexible                              | Rigid | Flexible                              | Rigid |
|  | 35                                    |       | 95                                    | 120   |

Note : when the cross-section exceeds the maximum value specified for the material in the table, the allowable current is limited to the indicated value.

#### Spreaders (incoming or outgoing)

- Set of 3 (for 3P) Cat.No M7A50
- Set of 4 (for 4P) Cat.No M7A51

#### Rear terminals (incoming or outgoing)

- Set of 3 (for 3P) Cat.No M7A54
- Set of 4 (for 4P) Cat.No M7A55

### 7.7 Interlock mechanism

It is used for interlocking 2 Megatiker M3 125, either with another Megatiker M3 125 or with a Megatiker M3 160 .

It is not possible to use other accessories than those recommended below for interlocking Megatiker M3 125 circuit breakers.

- Interlock mechanism – standard version (for fixed version) Cat.No M7I01
- Interlock mechanism – for electronic module (for fixed version) Cat.No M7I02
- Interlock plate Cat.No M7I04

## 8. MARKING

Product (both circuit breakers and trip-free switches) are provided with labelling in full conformity to the referred standard and directives requirements by laser or sticker labels (for illustrative purposes only):

#### Product laser label on front

- Manufacturer responsible
- Denomination, type product, code
- Standard conformity
- Standard characteristics declared
- Coloured identification of Icu at 415 V

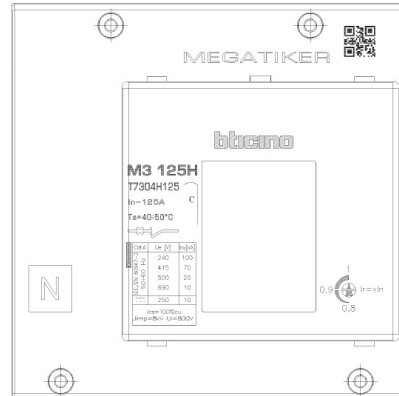

#### Product sticker label on side

- Manufacturer responsible
- Denomination and type product
- Standard conformity
- Mark/Licence (if any)
- Directive requirements
- Bar code identification product
- Manufacturing Country

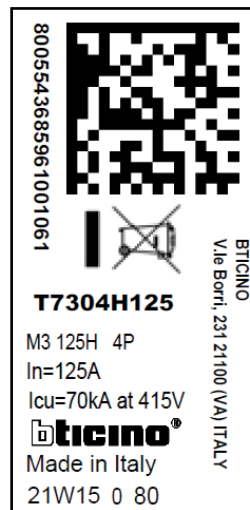

# Megatiker M3 125 thermal magnetic circuit breakers and MS3 125 trip-free switches

Cat.Nos:  
T7303F16/20/25/32/40/50/63/80/100/125-T7304F16/20/25/32/40/50/63/80/100/125  
T7303N16/20/25/32/40/50/63/80/100/125-T7304N16/20/25/32/40/50/63/80/100/125  
T7303H16/20/25/32/40/50/63/80/100/125-T7304H16/20/25/32/40/50/63/80/100/125  
T7303L16/20/25/32/40/50/63/80/100/125-T7304L16/20/25/32/40/50/63/80/100/125  
T7303S125-T7304S125

## 8. MARKING (continued)

### Mark sticker label on side

- Product code
- Mark/Licence (if any)
- Country deviation, if any

**T7304H125**

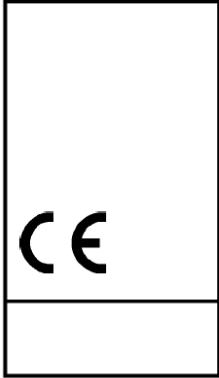

### Packaging sticker label

- Manufacturer responsible
- Denomination and type product
- Mark/Licence (if any)
- Directive requirements
- Bar code identification product

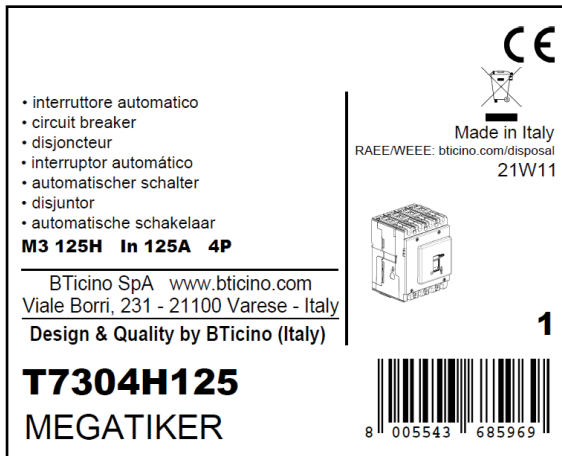

**9. CURVES**

■ **9.1 Thermal magnetic tripping curve (rated current  $I_n \leq 80$  A)**

Update: 11/06/2019

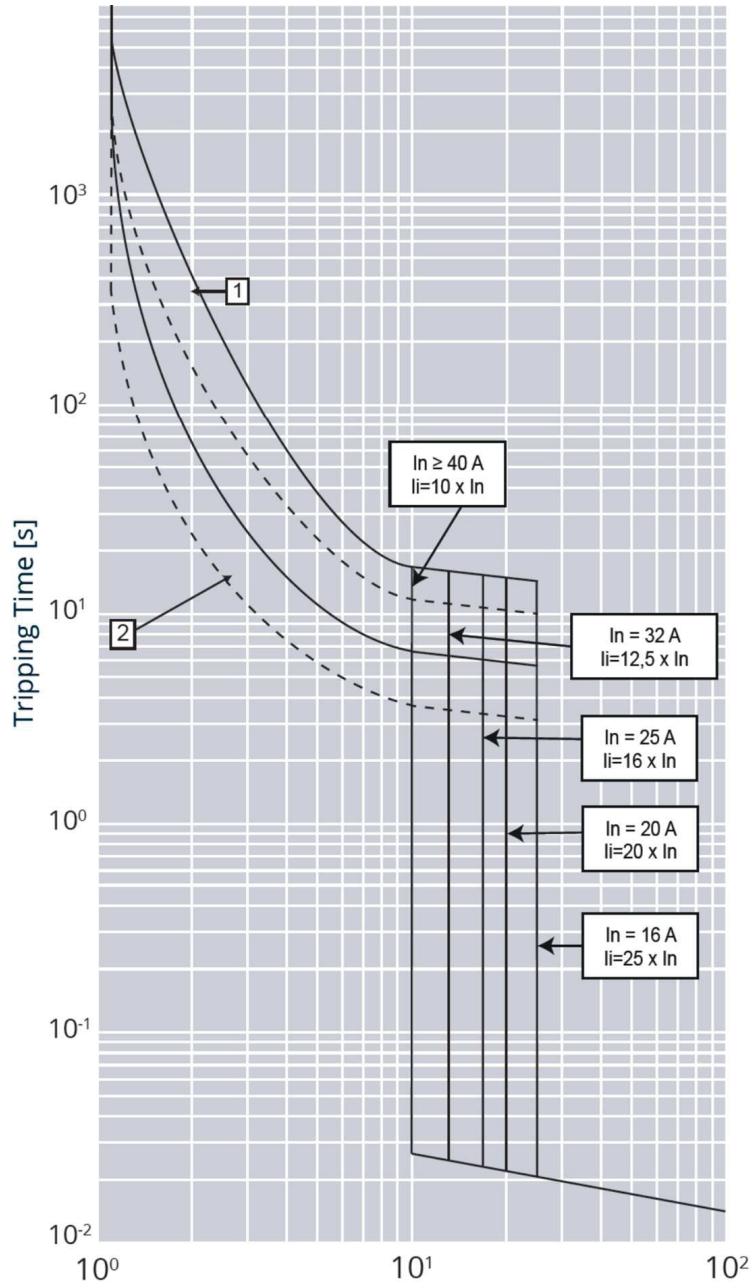

$I_{cu} = 36-50-70-100$  kA     $I_{max} = 125$  A    3-4 P     $U_e = 415$  V~ (IEC/EN 60947-2)

| Value   | Description                    |
|---------|--------------------------------|
| t       | Time                           |
| I       | Current                        |
| $I_n$   | Rated current                  |
| $I_r$   | Long time setting current      |
| Curve 1 | Characteristic with cold start |
| Curve 2 | Characteristic with hot start  |

**9. CURVES (continued)**

■ 9.2 Thermal magnetic tripping curve (rated current  $I_n > 80A$ )

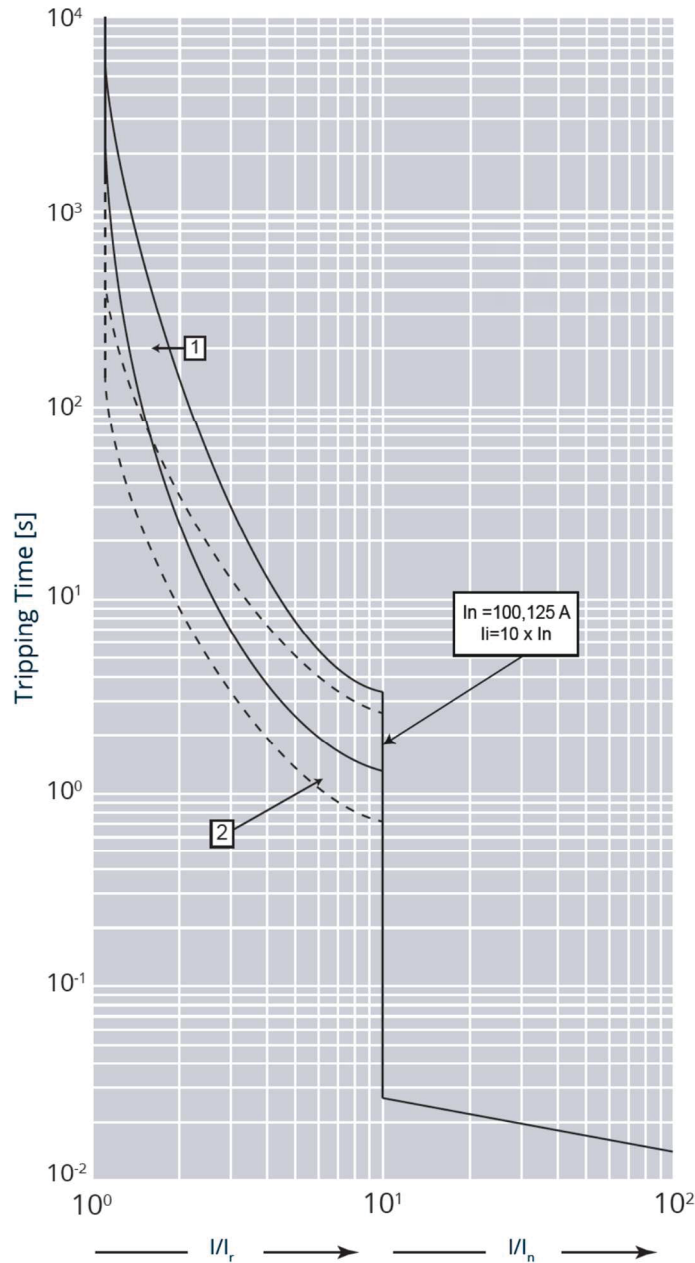

$I_{cu} = 70-100 \text{ kA}$      $I_{max} = 125 \text{ A}$     3-4 P     $U_e = 415 \text{ V} \sim (\text{IEC/EN } 60947-2)$

| Value   | Description                    |
|---------|--------------------------------|
| t       | Time                           |
| I       | Current                        |
| $I_n$   | Rated current                  |
| $I_r$   | Long time setting current      |
| Curve 1 | Characteristic with cold start |
| Curve 2 | Characteristic with hot start  |

**9. CURVES (continued)**

■ **9.3 Pass-through specific energy characteristic curve (breaking capacity  $I_{cu} \leq 50\text{ kA}$ )**

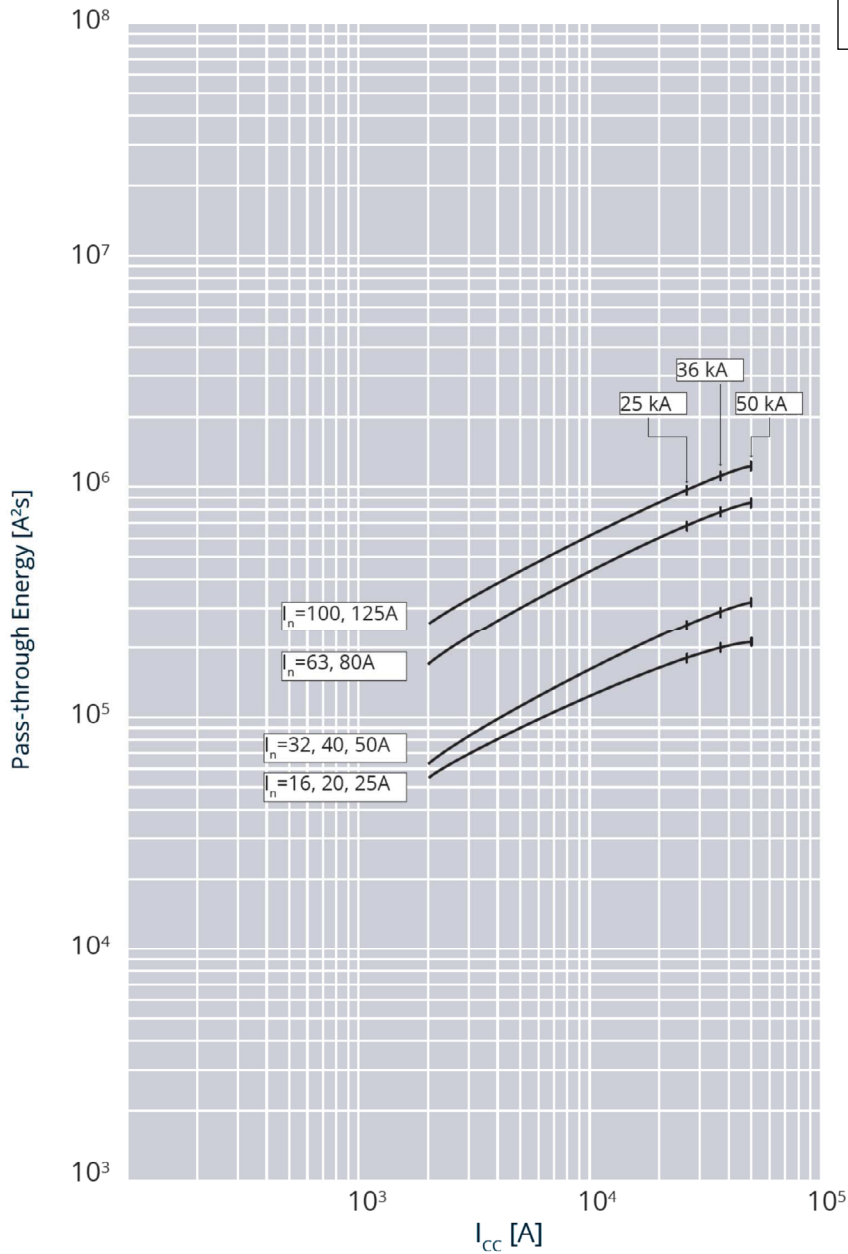

$I_{cu} = 36-50-70-100\text{ kA}$      $I_{max} = 125\text{ A}$     3-4 P     $U_e = 415\text{ V}\sim$  (IEC/EN 60947-2)

| Value                       | Description                  |
|-----------------------------|------------------------------|
| $I_{cc}$                    | Short circuit current        |
| $I^2t\text{ (A}^2\text{s)}$ | Pass-through specific energy |

**9. CURVES (continued)**

■ **9.4 Pass-through specific energy characteristic curve (breaking capacity  $I_{cu} > 50\text{kA}$ )**

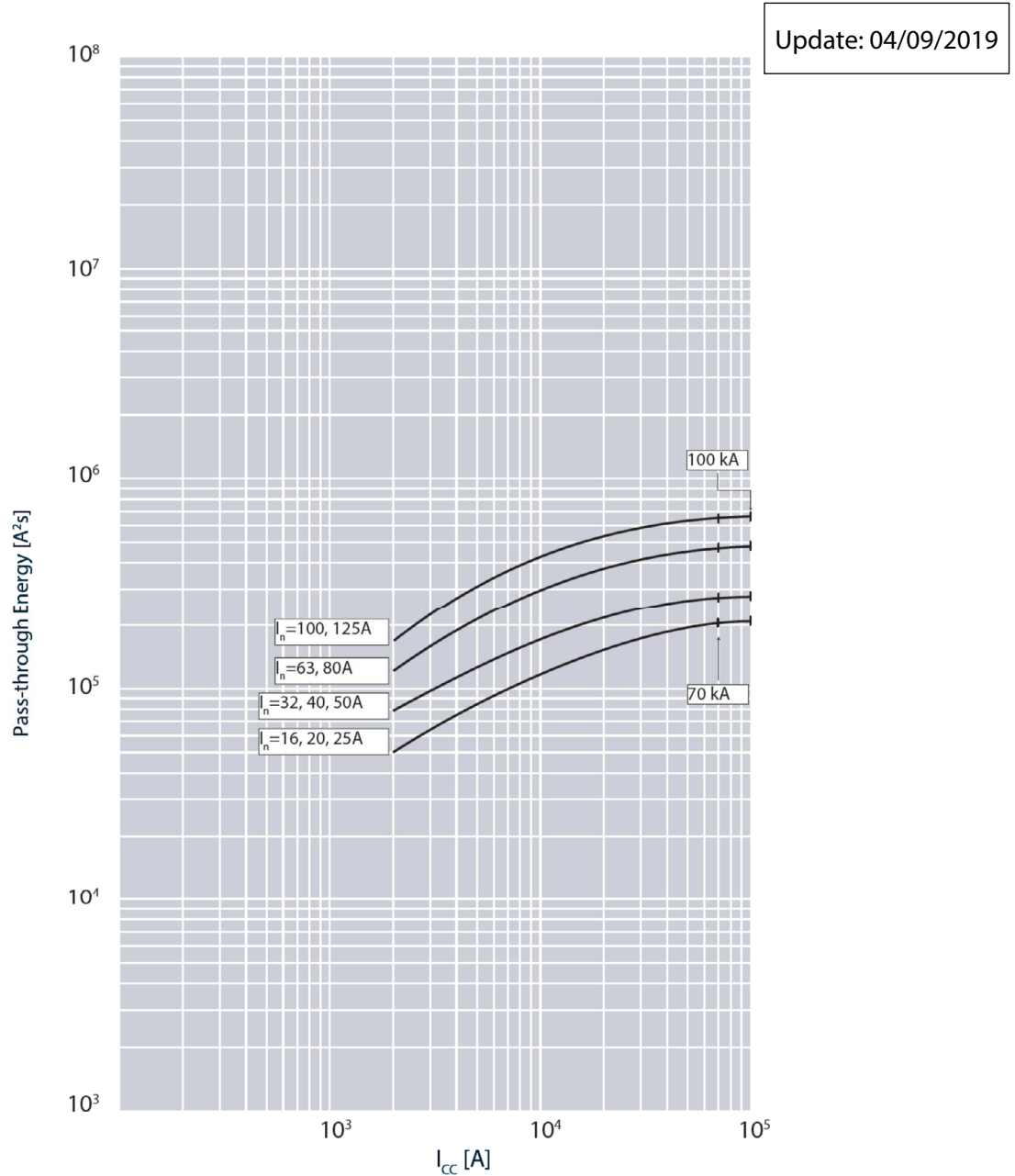

$I_{cu} = 36-50-70-100\text{ kA}$      $I_{max} = 125\text{ A}$     3-4 P     $U_e = 415\text{ V}\sim$  (IEC/EN 60947-2)

| Value                     | Description                  |
|---------------------------|------------------------------|
| $I_{cc}$                  | Short circuit current        |
| $I^2t$ (A <sup>2</sup> s) | Pass-through specific energy |

**9. CURVES (continued)**

■ **9.5 Cut-off peak current characteristic curve (kA) (breaking capacity  $I_{cu} \leq 50\text{kA}$ )**

Update: 04/02/2020

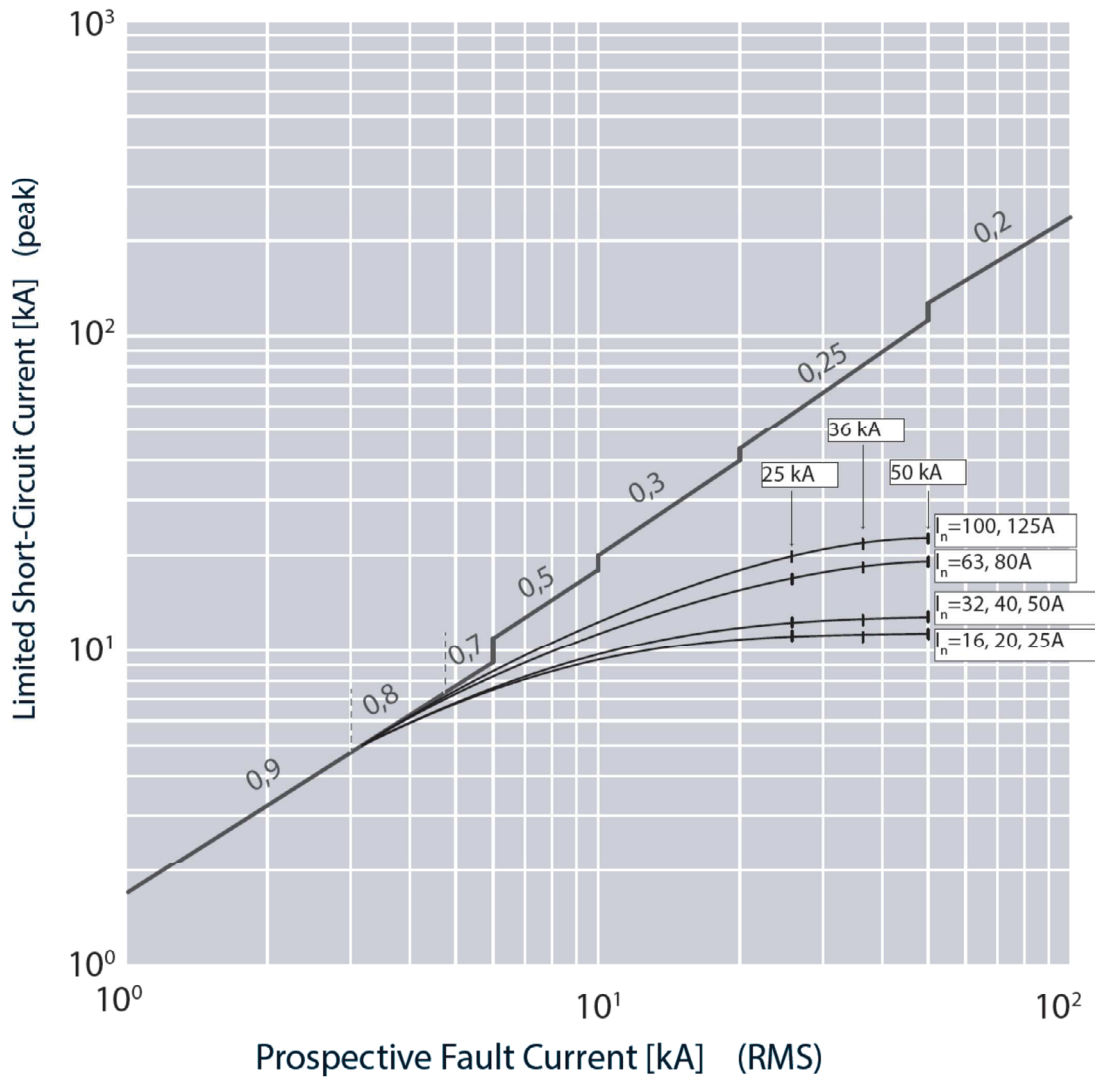

$I_{cu} = 36-50-70-100\text{ kA}$      $I_{max} = 125\text{ A}$     3-4 P     $U_e = 415\text{ V}\sim$  (IEC/EN 60947-2)

| Value    | Description   |
|----------|---|
| $I_{cc}$ | Estimated short circuit symmetrical current (RMS value) |
| $I_p$    | Maximum short circuit peak current                      |

**9. CURVES (continued)**

**9.6 Cut-off peak current characteristic curve (kA) (breaking capacity  $I_{cu} > 50\text{kA}$ )**

Update: 04/02/2020

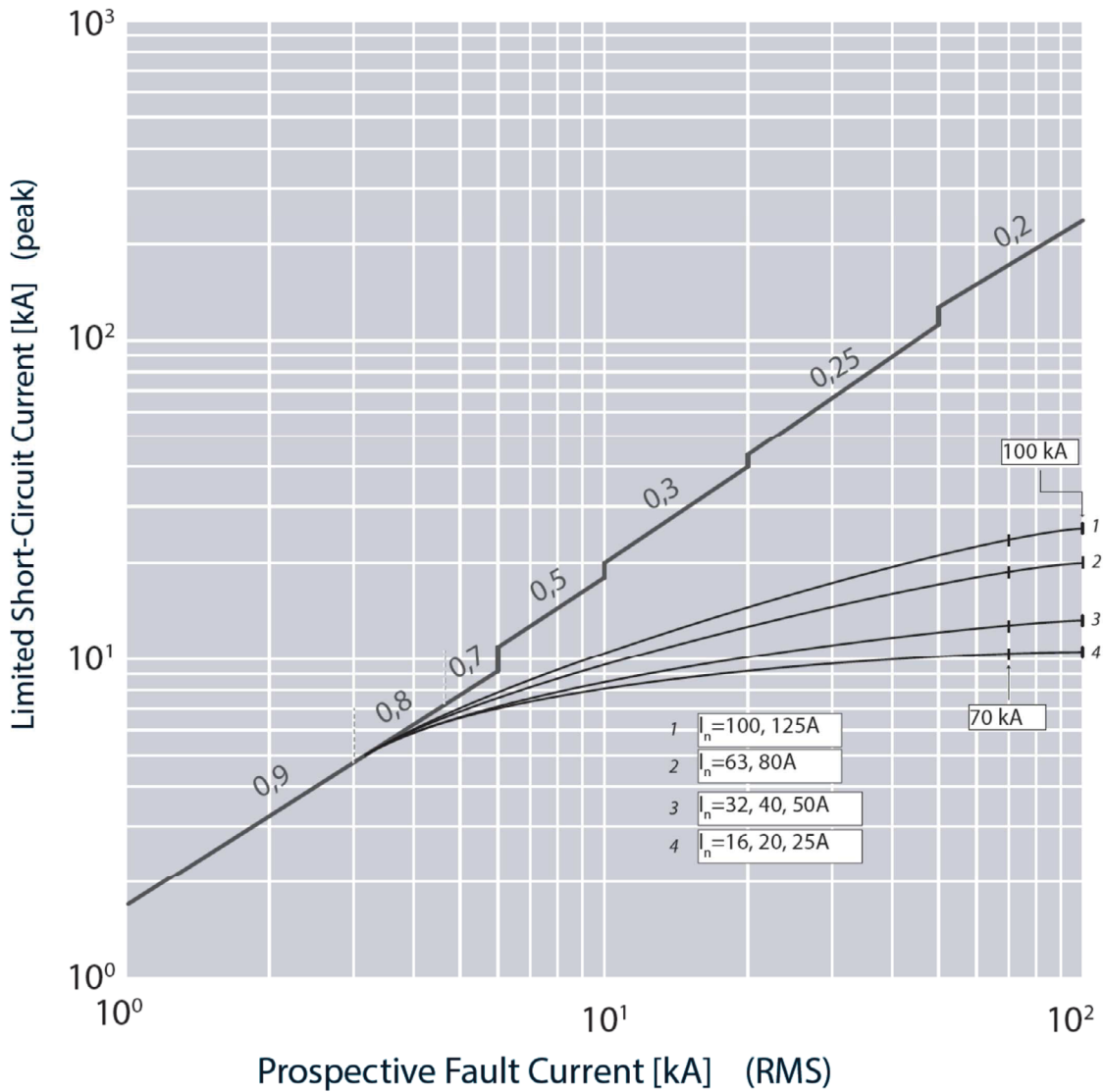

| $I_{cu} = 70-100\text{ kA}$ | $I_{max} = 125\text{ A}$                                | 3-4 P | $U_e = 415\text{ V} \sim$ (IEC/EN 60947-2) |
|-----------------------------|---|-------|--|
| Value                       | Description   |       |  |
| $I_{cc}$                    | Estimated short circuit symmetrical current (RMS value) |       |  |
| $I_p$                       | Maximum short circuit peak current                      |       |  |

# Megatiker M3 125 thermal magnetic circuit breakers and MS3 125 trip-free switches

Cat.Nos:

T7303F16/20/25/32/40/50/63/80/100/125-T7304F16/20/25/32/40/50/63/80/100/125  
T7303N16/20/25/32/40/50/63/80/100/125-T7304N16/20/25/32/40/50/63/80/100/125  
T7303H16/20/25/32/40/50/63/80/100/125-T7304H16/20/25/32/40/50/63/80/100/125  
T7303L16/20/25/32/40/50/63/80/100/125-T7304L16/20/25/32/40/50/63/80/100/125  
T7303S125-T7304S125

## 10. STANDARDS AND REGULATIONS

Megatiker M3 range of product concerning circuit-breakers and trip-free switches exceeds compliance with the IEC/EN standard 60947-2 and 60947-3 respectively.

Certification available by IECEE CB-scheme or LOVAG Compliance scheme. Megatiker M3 range respects the European Directives :

**RoHS:** Compliance with the 2011/65/EU Directive (RoHS), as modified by the 2015/863/EU Delegated Directive, on the restriction of the use of certain hazardous substances in electrical and electronic equipment.

**REACH:** The substances identified as SVHC (Substances of Very High Concern) according to the REACH Regulation (1907/2006), if present in the products at a concentration above 0.1% weight by weight, are declared inside the European SCIP database. At the date of publication of this document none of the substance listed in the annex XIV is found in this product.

**WEEE:** WEEE Directive (2012/19/EU): the sale of this product includes a contribution to the appointed environmental bodies of each European country in charge of handling, at the end of their life, the products falling within the scope of the EU Directive on Electrical and Electronic Equipment Waste.

**Packaging:** Design and manufacture of packaging compliant with European Directive 94/62/CE.

For specific information, please contact BTicino support.

## 11. OTHER INFORMATION

**XLPro Calcul:** Calculation notes creation software, addressed to installers, design office and maintenance operators. Definition of the electrical characteristics of a low voltage installation in compliance with the applicable standards

**XLPro<sup>3</sup> Tool Selectivity and backup/BTicino Selectivity and backup:** Software dedicated to installers, panelbuilders and design offices. Definition of the selectivity and backup values of an association of electrical devices and obtention of the tripping curves of the selected products.

**XLPro Panels:** Distribution panel design software, addressed to panelbuilders and electrical panel designers. Design of the electrical distribution of the panel, production of electrical diagrams, establishment of products and overall costing of the project.

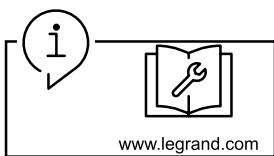

**Workshop book:** mounting informations, equipments, accessories and spare parts available on e-catalog.

**Instruction sheet:** detailed mounting procedures, available on e-catalog.

**PEP:** available on e-catalog.

For further technical information, please contact BTicino technical support.

Unless otherwise indicated, data reported in this document refers exclusively to test conditions according to product standards.

For different conditions of use of the product, inside electrical equipment or in any different installation context, refer to the regulatory requirements of the equipment, local regulations and design specifications of the system.