

Megatiker M2 250 thermal magnetic circuit breakers

Megatiker MS2 250 trip-free switches

Cat.Nos:

T723B100 - T723B160 - T723B200 - T723B250 - T724B100
T724B160 - T724B200 - T724B250 - T723F100 - T723F160
T723F200 - T723F250 - T724F100 - T724F160 - T724F200
T724F250 - T723N100 - T723N160 - T723N200 - T723N250
T724N100 - T724N160 - T724N200 - T724N250- T723S250
T724S250

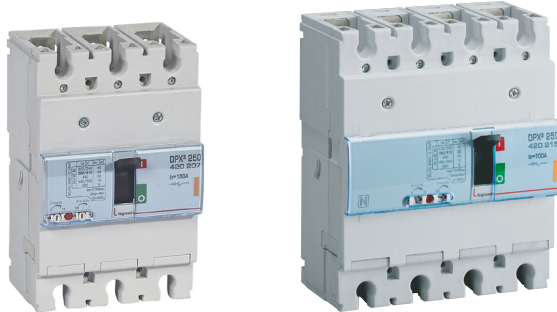

CONTENT

Page

1. Use	1
2. Range	1
3. Technical characteristics	1
4. Installation rules	3
5. Dimensions and weight	4
6. Connections	6
7. Equipments and accessories	6
8. Marking	8
9. Curves	9
10. Standards and regulations	12
11. Other information	12

1. USE

Megatiker range has been developed to give a new solution of protection devices for a more precise approach in flow installations in order to offer the correct answer for different project needs.

Megatiker range provides a complete project approach in premium market segment, offering a range completely suitable for medium power application with high performance breakers in compact dimensions and at a competitive costs

2. RANGE

■ 2.1 Megatiker M2 thermal magnetic circuit breaker

Icu	25 kA		36 kA		
	In (A)	3P	3P+N/2	3P	3P+N/2
100	T723B100	T724B100	T723F100	T724F100	
160	T723B160	T724B160	T723F160	T724F160	
200	T723B200	T724B200	T723F200	T724F200	
250	T723B250	T724B250	T723F250	T724F250	

Icu	50 kA		
	In (A)	3P	3P+N/2
100	T723N100	T724N100	
160	T723N160	T724N160	
200	T723N200	T724N200	
250	T723N250	T724N250	

■ 2.2 Megatiker MS2 250 trip-free switch

In (A)	3P	3P+N/2
250	T723S250	T724S250

■ 2.3 Composition

Megatiker M2 thermal magnetic is supplied with:

- fixing screws
- connection plates for bars and cable lugs
- insulating shields (phase barrier)

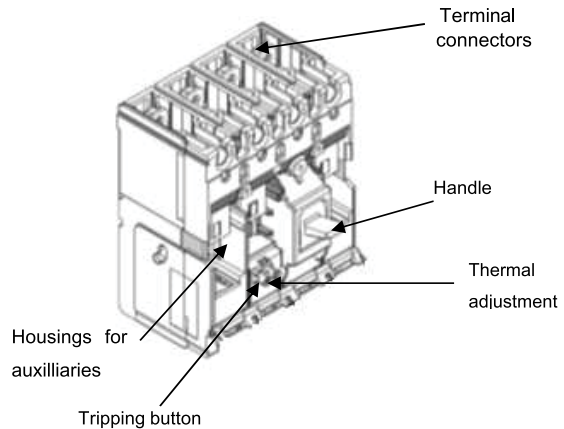

3. TECHNICAL CHARACTERISTICS

■ 3.1 Electrical characteristics

Megatiker M2 thermal magnetic circuit breakers	
Rated current	100 A, 160 A, 200 A, 250 A
Poles	3P - 4P
Pole pitch	35 mm
Rated insulation voltage (50/60Hz) Ui	800 V
Rated operating voltage (50/60Hz) Ue	690 V
Rated impulse withstand current Uimp	8 kV
Rated frequency	50 Hz - 60 Hz
Reference ambient temperature	40 °C - 50 °C
Operating temperature	-25 °C to 70 °C
Electrical endurance at In (cycles)	8000
Electrical endurance at 0.5 x In (cycles)	10000
Utilization category	A
Suitable for isolation	Yes
Type of protection	Thermal-magnetic
Thermal adjustment Ir	(0.8 ÷ 1) x In
Magnetic adjustment li (A)	5 - 10 x In
Neutral protection for 4P (%th of phase pole)	100
Reverse feed	Yes

Megatiker M2 250 thermal magnetic circuit breakers

Megatiker MS2 250 trip-free switches

Cat.Nos:
T723B100 - T723B160 - T723B200 - T723B250 - T724B100
T724B160 - T724B200 - T724B250 - T723F100 - T723F160
T723F200 - T723F250 - T724F100 - T724F160 - T724F200
T724F250 - T723N100 - T723N160 - T723N200 - T723N250
T724N100 - T724N160 - T724N200 - T724N250- T723S250
T724S250

3. TECHNICAL CHARACTERISTICS (continued)

■ 3.1 Electrical characteristics (continued)

Megatiker MS2 250 trip-free switches	
Uninterrupted nominal current Ie	250 A
Short-time resistive current Icw for 1s	3 kA
Rated short-circuit making capacity Icm	4.5 kA
Rated insulation voltage Ui	800 V~
Maximum rated operating voltage Ue	690 V~/=
Rated impulse withstand voltage Uimp	8 kV
Utilisation category	AC22-23A
Suitable for isolation	Yes
Rated frequency (Hz)	50 Hz - 60 Hz
Operating temperature	-25 °C to 70 °C
Electrical endurance at In (cycles)	8000
Electrical endurance at 0.5 x In (cycles)	10000
Reverse feed	Yes

The maximum temperature allowed on power terminals is 125 °C (absolute). For details, see IEC 60947-1 and 60947-2.

Switch disconnectors category (for use in DC)

	1P*	2P in series*	3P in series*	3P+N/2 in series*
In (A)	60 V	110 V	250 V	500 V
250	DC23			

*See page 6 for Connection modality of the DC trip-free switches

Breaking capacity (3P and 3P+N/2)

IEC 60947-2	Breaking capacity (kA) & Ics			
	Ue	Icu		
		25 kA	36 kA	50 kA
220/240 V~	40	60	80	
380/415 V~	25	36	50	
440/460 V~	20	30	40	
480/500 V~	10	25	30	
480/550 V~	9	20	22	
600 V~	9	20	22	
690 V~	8	16	18	
Ics (% Icu)	100			
Rated making capacity under short circuit Icm				
Icm (kA) at 415 V	52.5	75.6	105	

Breaking capacity in DC (kA) (estimated values)

Icu	In (A)	1P*				2P in series *				3P in series *			
		60 V	60 V	110 V	250 V	110 V	250 V	110 V	250 V	110 V	250 V	500 V	
25 kA	100 to 250	25	25	25	10	25	12	10	25	12	10		
36 kA		35	36	35		36	16						
50 kA		35	50	35		50	20						

*See page 6 for Connection modality of the DC breaker.
 DC breaking capacity in the table respect the standards.
 The positive tolerance is between 0 % to 5 % of voltage status

Rated current (In) at 40 °C / 50 °C

In (A)	Phases limit trip current			
	Thermal (I _r)		Magnetic (I _i)	
	L1 - L2 - L3	N	L1 - L2 - L3	N
100	100		1000	
160	160		1600	
200	200		2000	
250	250		2500	

■ 3.2 Mechanical characteristics

Mechanical endurance (cycles): 20000

Mechanical endurance with motor control (cycles): 20000

Load operations

	Force on handle (N)
Opening operation	45
Closing operation	78
Restore operation	75

■ 3.3 Electrodynamic forces

The table below shows an indication of suggested distances to keep between the breaker and the first fixing point of the conductor and bars in order to reduce the effects of the electrodynamic stresses that may be created during a short circuit. In the realization of anchorage system it is recommend the use of isolators suitable for the type of conductor used and the operating voltage.

I _{cc} (kA)	Maximum distance (mm)
25	400
36	350
50	300

According to conductor type and bar system (except BTicino bar kits), the choice of the distance to keep is to be calibrated by the installer. Also, the installer must take into account the weight of the conductors so that it does not affect the electrical junction between the conductor itself and the connection point.

■ 3.4 Power losses per pole under In (W)

Circuit breakers				
In (A)	100	160	200	250
Lugs	7.0	12.5	15.1	19.1
Cage terminals	7.3	13.2	16.2	20.7
High capacity cage terminals	7.3	13.3	16.3	21.0
Spreaders	7.3	13.3	16.3	21.0
Rear terminals*	7.3	13.3	16.3	21.0
Plug-in version*	10.3	20.9	28.3	39.7

Note: power losses in the table above are referred and measured as described in the standard IEC 60947-2 (Annex G) for circuit-breakers. Values in the table are referred to a single phase.

* Products available only for maintenance of existing installations. For further information, please contact BTicino. If you need to integrate these accessories into a new installation, please refer to the Megatiker M3 range

Megatiker M2 250 thermal magnetic circuit breakers

Megatiker MS2 250 trip-free switches

Cat.Nos:
T723B100 - T723B160 - T723B200 - T723B250 - T724B100
T724B160 - T724B200 - T724B250 - T723F100 - T723F160
T723F200 - T723F250 - T724F100 - T724F160 - T724F200
T724F250 - T723N100 - T723N160 - T723N200 - T723N250
T724N100 - T724N160 - T724N200 - T724N250- T723S250
T724S250

3. TECHNICAL CHARACTERISTICS (continued)

■ 3.4 Power losses per pole under I_n (W) (continued)

Trip-free switches	
I_n (A)	250
Lugs	13.3
Cage terminals	14.5
High capacity cage terminals	14.7
Spreaders	14.7
Rear terminals*	14.7
Plug-in version*	34.0

Note: power loss in the table above are referred and measured as described in the standard IEC 60947-3 for trip-free switches. Values in the table are referred to a single phase.

* Products available only for maintenance of existing installations. For further information, please contact BTicino. If you need to integrate these accessories into a new installation, please refer to the Megatiker M3 range

4. INSTALLATION RULES

According to IEC/EN 60947-1.

Temperature deratings

Rated current and his adjustment has to be considered relating to a rise or fall of ambient temperature and to a different version or installation conditions. The table below indicates the maximum long-time (LT) protection setting depending on the ambient temperature.

I_n (A)	Temperature T_a (°C)											
	-25	-20	-10	-5	0	10	20	30	40	50	60	70
100	135	132	128	126	123	120	112	102	100	100	90	84
160	216	211	205	201	197	192	179	163	160	160	143	134
200	270	264	256	251	246	240	224	203	200	200	179	168
250	338	330	320	314	308	300	280	254	250	250	224	210

For derating temperature with other configurations, see table below.

Ambient temperature	30 °C		40 °C		50 °C		60 °C		70 °C		
	I_{max} (A)	I_r / I_n	I_{max} (A)	I_r / I_n	I_{max} (A)	I_r / I_n	I_{max} (A)	I_r / I_n	I_{max} (A)	I_r / I_n	
Fixed version - vertical installation											
Cage terminals, flexible cable	263	1.05	250	1	250	1	225	0.90	213	0.85	
Lugs, flexible cable	250	1	250	1	250	1	238	0.95	225	0.90	
Lugs, flexible cable + sealable terminal shields											
Spreaders, flexible cable											
Rear flat staggered terminal*, flexible/rigid cable + sealable terminal shields											
Fixed version - horizontal installation											
Cage terminals, flexible cable	263	1.05	250	1	250	1	225	0.90	213	0.85	
Lugs, flexible cable	250	1	250	1	250	1	238	0.95	225	0.90	
Lugs, flexible cable + sealable terminal shields											
Spreaders, flexible cable											
Rear flat staggered terminal*, flexible/rigid cable + sealable terminal shields											

For further technical information, please contact BTicino technical support.

* Products available only for maintenance of existing installations. For further information, please contact BTicino. If you need to integrate these accessories into a new installation, please refer to the Megatiker M3 range

Climatic conditions: according to IEC/EN 60947-1 Annex Q, Cat. F subject to temperature, humidity, vibration, shock and salt mist.

Electromagnetic disturbances (EMC): for Megatiker M2 circuit breakers, according to IEC/EN 60947-2 Annex F.

Pollution degree: for Megatiker M2 circuit breakers, degree 3, according to IEC/EN 60947-2.

Megatiker M2 250 thermal magnetic circuit breakers

Megatiker MS2 250 trip-free switches

Cat.Nos:

T723B100 - T723B160 - T723B200 - T723B250 - T724B100
 T724B160 - T724B200 - T724B250 - T723F100 - T723F160
 T723F200 - T723F250 - T724F100 - T724F160 - T724F200
 T724F250 - T723N100 - T723N160 - T723N200 - T723N250
 T724N100 - T724N160 - T724N200 - T724N250- T723S250
 T724S250

4. INSTALLATION RULES (continued)

Altitude

Altitude derating for Megatiker M2 and Megatiker MS2 250

Altitude (m)	2000	3000	4000	5000
U _e (V)	690	590	520	460
I _n (A) (T _a = 40 °C / 50 °C)	1 x I _n	0.98 x I _n	0.93 x I _n	0.9 x I _n

5. DIMENSIONS AND WEIGHT

■ 5.1 Dimensions (mm)

3P (W x H x D): 105 x 165 x 100

3P+N/2 (W x H x D): 140 x 165 x 100

Implantation

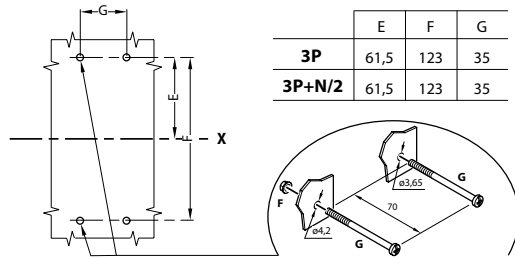

	E	F	G
3P	61,5	123	35
3P+N/2	61,5	123	35

Fixed version

Device without accessories

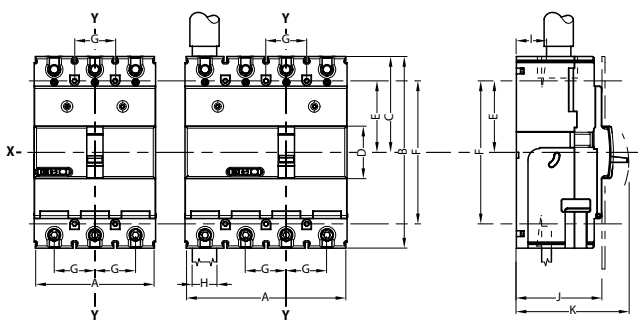

	A	B	C	D	E	F
3P	105	165	82.5	45	61.5	123
3P+N/2	140	165	82.5	45	61.5	123

	G	H	I	J	K
3P	35	28.5	18	74	97
3P+N/2	35	28.5	18	74	97

With front terminal

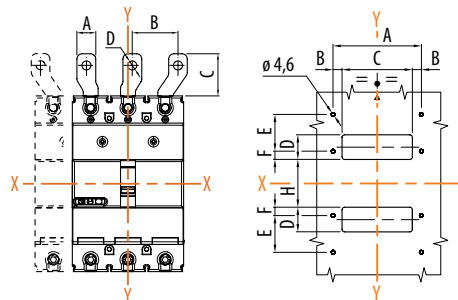

A	B	C	D
33	48.5	54.75	13

With motor operator

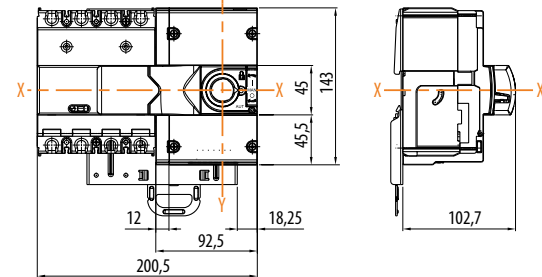

With rotary handle

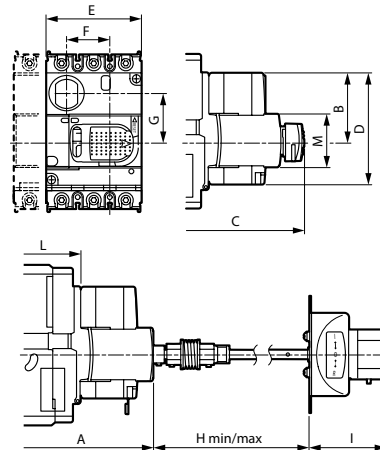

A	B	C	D	E	F
122	57	155	94	80.5	40.5
G	H min.	H max.	I	L	M
41.7	132	361	62	74	45

With spreaders

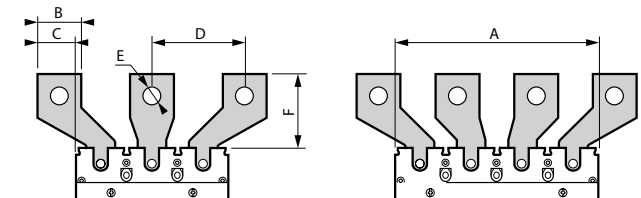

	A	B	C	D	E	F
3P	105	30	27	63.5	13	50
3P+N/2	140	30	27	63.5	13	50

Megatiker M2 250 thermal magnetic circuit breakers

Megatiker MS2 250 trip-free switches

Cat.Nos:
 T723B100 - T723B160 - T723B200 - T723B250 - T724B100
 T724B160 - T724B200 - T724B250 - T723F100 - T723F160
 T723F200 - T723F250 - T724F100 - T724F160 - T724F200
 T724F250 - T723N100 - T723N160 - T723N200 - T723N250
 T724N100 - T724N160 - T724N200 - T724N250- T723S250
 T724S250

5. DIMENSIONS AND WEIGHT (continued)

5.1 Dimensions (mm) (continued)

With faceplate

Lateral view

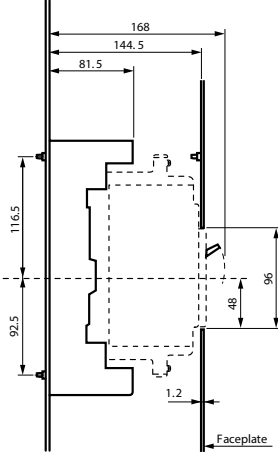

Front view

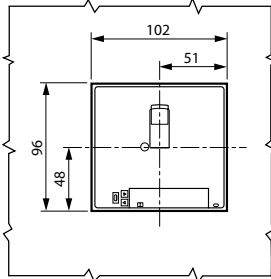

With direct rotary handle

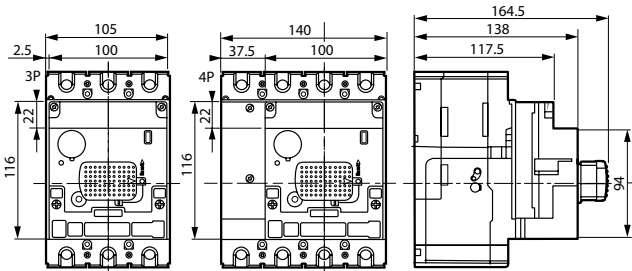

With vary depth rotary handle

IP 55

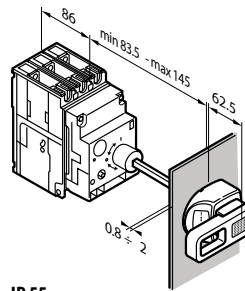

IP 40

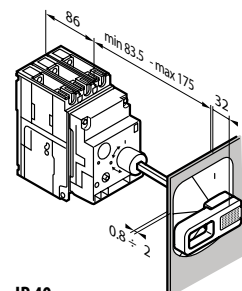

IP 55

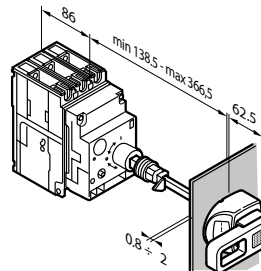

IP 40

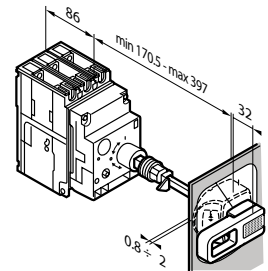

With interlock mechanism

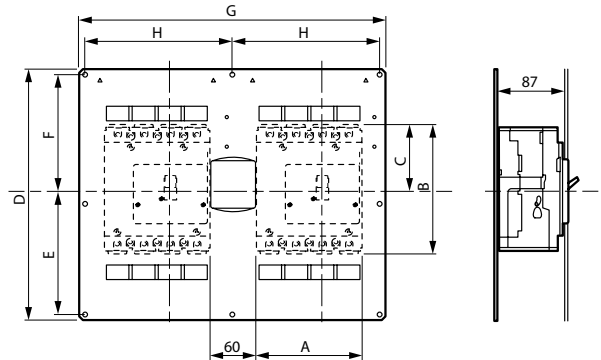

	A	B	C	D	E	F	G	H
3P	105	165	82.5	340	165	160	415	200
3P+N/2	140	165	82.5	340	165	160	415	200

5.2 Weight

Configuration	Weight (kg)	
	3P	3P+N/2
Circuit breaker/trip-free switch	1.9	2.4
Direct rotary handle*	0.30	
Vary depth rotary handle*	0.27	
Motor operator*	1.22	
Interlock*	1.08	
Spreader*	0.26	0.35

* to add to device weight

Megatiker M2 250 thermal magnetic circuit breakers

Megatiker MS2 250 trip-free switches

Cat.Nos:

T723B100 - T723B160 - T723B200 - T723B250 - T724B100
 T724B160 - T724B200 - T724B250 - T723F100 - T723F160
 T723F200 - T723F250 - T724F100 - T724F160 - T724F200
 T724F250 - T723N100 - T723N160 - T723N200 - T723N250
 T724N100 - T724N160 - T724N200 - T724N250- T723S250
 T724S250

6. CONNECTIONS

Possible way of assembly on DIN rail:

- vertical
- horizontal

To ensure the circuit breaker's connection, it is possible to use:

- busbars;
- cables lugs;
- cables;
- cage terminals;

	Cage terminals capacity
Bars	28.5 mm wide max.
Flexible cables	1.5 mm ² min. / 120 mm ² max.
Rigid cables	1.5 mm ² min. / 150 mm ² max.

For detailed mounting procedures, see instruction sheet.

DC connections modality for breakers

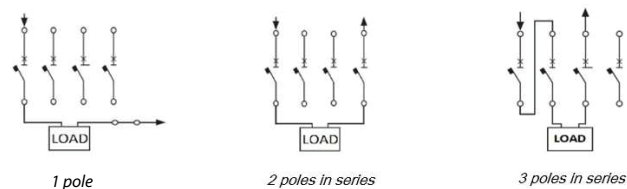

DC connections modality for trip-free switches (polarity can be inverted)

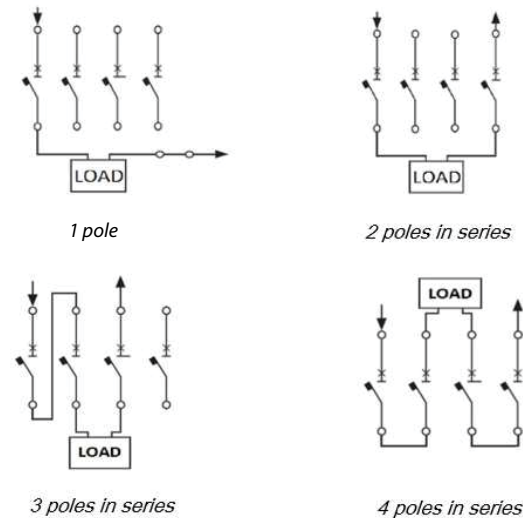

Applied to DC breaker/switch networks insulated from the ground

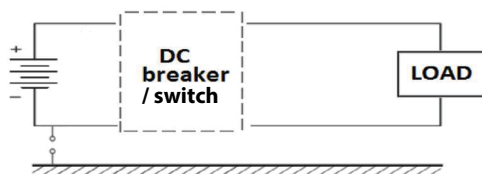

7. EQUIPMENTS AND ACCESSORIES

7.1 Releases

There are 3 types of releases (suitable for Megatiker M3 125/160/250 and Megatiker M1 and M2):

Shunt releases (ST)

12 V \sim /=	Cat.No M7S012
24 V \sim /=	Cat.No M7S024
48 V \sim /=	Cat.No M7S048
110 to 130 V \sim	Cat.No M7S110
220 to 277 V \sim	Cat.No M7S230
380 to 480 V \sim	Cat.No M7S415
Maximum power = 400 VA / W	

Undervoltage releases (UVR)

12 V \sim /=	Cat.No M7U012
24 V \sim /=	Cat.No M7U024
48 V \sim /=	Cat.No M7U048
110 to 130 V \sim /=	Cat.No M7U110
220 to 240 V \sim	Cat.No M7U230
277 V \sim	Cat.No M7U277
380 to 415 V \sim	Cat.No M7U415
440 to 480 V \sim	Cat.No M7U480
Maximum power = 4 VA	
Circuit breaker opening time < 50 ms	

Time-lag undervoltage releases (800 ms)

- Release	Cat.No M7UEM
to be equipped with a time-lag module:	
- 230 V \sim	Cat.No M7000MR/230
- 400 V \sim	Cat.No M7000MR/400

Time lag module

For UVR 24V \sim /= M7000E/024

7.2 Auxiliary contacts

It is used to show the state of the contacts or opening of the Megatiker on a fault.

Standard auxiliary contact (OC) / Fault signal (CTR) Cat.No M7X01

Rated voltage (Vn)	Intensity (A)
24 V \sim	5
48 V \sim	1.7
110 V \sim	0.5
230 V \sim	0.25
110 V \sim	4
230/250 V \sim	3

- Set of connectors for auxiliary contacts Cat.No M7B05
- Auxiliary contacts (1NC and 1 NO) Cat.No M7R13

Megatiker M2 250 thermal magnetic circuit breakers

Megatiker MS2 250 trip-free switches

Cat.Nos:
T723B100 - T723B160 - T723B200 - T723B250 - T724B100
T724B160 - T724B200 - T724B250 - T723F100 - T723F160
T723F200 - T723F250 - T724F100 - T724F160 - T724F200
T724F250 - T723N100 - T723N160 - T723N200 - T723N250
T724N100 - T724N160 - T724N200 - T724N250- T723S250
T724S250

7. EQUIPMENTS AND ACCESSORIES (continued)

7.2 Auxiliary contacts (continued)

Configurations

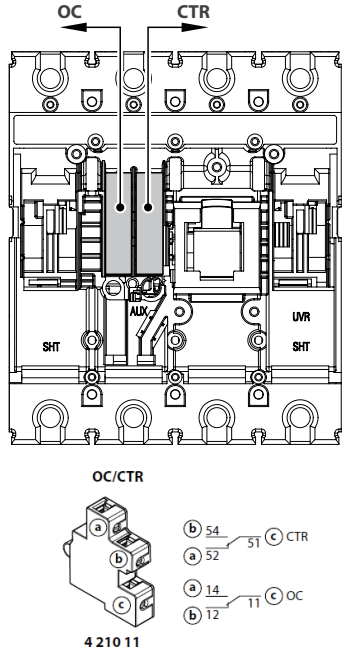

To get more information on auxiliary mounting procedures, please refer to product instruction sheet.

7.3 Rotary handles

There are 2 types of suited rotary handles (also compatible with Megatiker M1):

Direct on Megatiker (with auxiliary option and compatible with MAS)

- Standard (black) Cat.No M7R01
- For emergency use (red / yellow) Cat.No M7R03

Vary depth handle IP55 (with auxiliary option and compatible with MAS)

- Standard (black) Cat.No M7R05
- For emergency use (red/yellow) Cat.No M7R06

Locking accessories (for rotary handle with auxiliary option)

- For direct rotary handle:
- Key barrel and flat key N° ABA90GEL6149 Cat.No M7R07
 - Key barrel and star key N° HBA90GPS6149 Cat.No M7R08

For vary depth rotary handle:

- Key barrel and flat key N° ABA90GEL6149 Cat.No M7R10
- Key barrel and star key N°HBA90GPS6149 Cat.No M7R11

7.4 Motor operators

- Side motor operator 24 - 230 V~/= Cat.No M7M01

Locking accessories for side motor operator

- Key barrel and N° ABA90GEL6149 Cat.No M7M14
- Key barrel and star key N° HBA90GPS6149 Cat.No M7M15
- Padlock for side motor operator Cat.No M7M17

7.5 Mechanical accessories

Padlocks (for locking in "open" position)

- Megatiker padlock accessory for handle Cat.No M7X02
- Cat.No M7X02 is compatible with Megatiker M3 125/160/250 and Megatiker M1/M2.

Insulated shields (phase barriers)

- Set of 36 Cat.No M7X04

Sealable terminal shields

- for front terminals 3P Cat.No M7C07
- for front terminals 3P+N/2 Cat.No M7C08

Fixing plates for transfer switches

Plate for mounting and interlocking 2 Megatiker. It can be either 2 Megatiker M1 ; 2 Megatiker M2; or 1 Megatiker M1 and 1 Megatiker M2.
 For fixed version Cat.No M7X03

Fixing plates

- For fixing Megatiker M2 on DIN rail or on plate
- For Megatiker M2 3P/3P+N/2 Cat.No M7X06
- For Megatiker M2 3P/3P+N/2 with side mounting motor operator Cat.No M7M09

7.6 Connection accessories

Front spreaders

- Set of 3 (for 3P) Cat.No M7A03
 - Set of 4 (for 3P+N/2) Cat.No M7A04
- (Cat.Nos M7A03 / M7A04 are also compatible with Megatiker M3 250)

Cage terminals

- Set of 3 standard terminals for 1x150 mm² max (rigid) or 1x120 mm² (flexible) Cu/Al bar/cable lug (for Al cables In max 125 A) Cat.No M7X09
- Set of 4 standard terminals for 1x150 mm² max (rigid) or 1x120 mm² max (flexible) Cu/Al bar/cable lug (for Al cables In max 125 A) Cat.No M7X19

Cage terminal use specifications

	Cable standard suggested cross-section (mm ²)*		
	In (A)	Cu	Al
Standard cage terminals Cat.Nos M7X09/ M7X19	16	2.5	4
	20	2.5	4
	25	4	6
	32	6	10
	40	10	16
	50	10	16
	63	16	25
	80	25	35
	100	35	35
	125	50	70
	160	70	-
	200	95	-
	250	120	-

* The suggested cross-section are in compliance with standard IEC 60947-1 (ed.6 2020/04) and IEC 60947-2 (ed.5.1 2019/07)

Dimensions limits of cable for cage terminals

Standard cage terminals Cat.Nos M7X09/ M7X19	Min. cross-section (mm ²)		Max. cross-section (mm ²)	
	Flexible	Rigid	Flexible	Rigid

Note : when the cross-section exceeds the maximum value specified for the material in the table, the allowable current is limited to the indicated value.

Megatiker M2 250 thermal magnetic circuit breakers

Megatiker MS2 250 trip-free switches

Cat.Nos:

T723B100 - T723B160 - T723B200 - T723B250 - T724B100
 T724B160 - T724B200 - T724B250 - T723F100 - T723F160
 T723F200 - T723F250 - T724F100 - T724F160 - T724F200
 T724F250 - T723N100 - T723N160 - T723N200 - T723N250
 T724N100 - T724N160 - T724N200 - T724N250- T723S250
 T724S250

7. EQUIPMENTS AND ACCESSORIES (continued)

7.6 Connection accessories Cage terminal use specifications (continued)

- Screw terminals for bar connections (3P) Cat.No M7X28
- Screw terminals for bar connections (3P+N/2) Cat.No M7X38

8. MARKING

Product (both circuit breakers and trip-free switches) are provided with labelling in full conformity to the referred standard and directives requirements by laser or sticker labels (for illustrative purposes only):

Product laser label on front

- Manufacturer responsible
- Denomination, type product, code
- Standard conformity
- Standard characteristics declared
- Coloured identification of Icu at 415 V

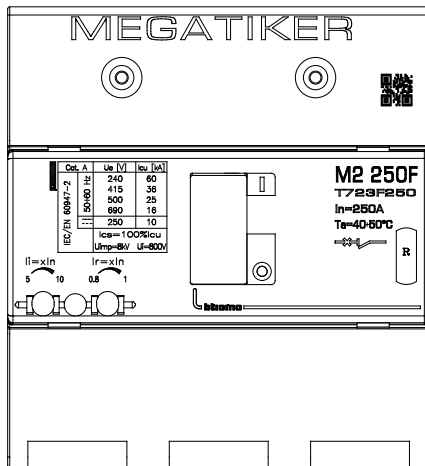

Product sticker label on side

- Manufacturer responsible
- Denomination and type product
- Standard conformity
- Mark/Licence (if any)
- Directive requirements
- Bar code identification product
- Manufacturing Country

Z1913ADC

**3P
In=250A
MGT**



2039191302502579291

Made in Italy
21W08 4 80

Mark sticker label on side

- Product code
- Mark/Licence (if any)
- Country deviation, if any

T723F250



BTICINO Viale Borri, 231-21100 (VA) ITALY

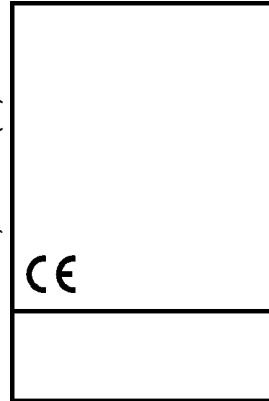

Packaging sticker label

- Manufacturer responsible
- Denomination and type product
- Mark/Licence (if any)
- Directive requirements
- Bar code identification product

- interruttore automatico
- circuit breaker
- disjoncteur
- interruptor automático
- automatischer schalter
- interruptor automático
- automatische schakelaar

M2 250F In 250A 3P

BTicino SpA www.bticino.com
 Viale Borri, 231 - 21100 Varese - Italy
 Design & Quality by BTicino (Italy)

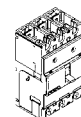

1

**T723F250
MEGATIKER**



9. CURVES

■ 9.1 Thermal magnetic tripping curve

Update: 19/04/2018

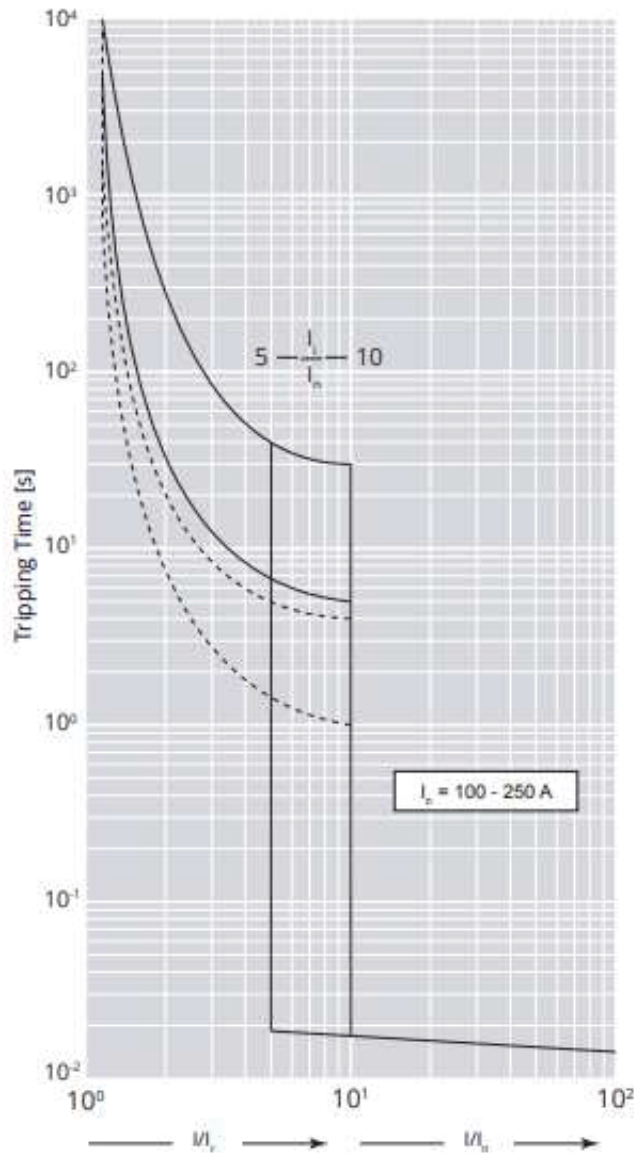

I_{cu} = 25-36-50 kA I_{max} = 250 A 3-3P+N/2 U_e = 415 V~

Value	Description
t	Time
I	Current
I _n	Rated current
I _r	Long time setting current
Curve 1	Characteristic with cold start
Curve 2	Characteristic with hot start

9. CURVES (continued)

■ 9.2 Pass-through specific energy characteristic curve

Update: 24/04/2018

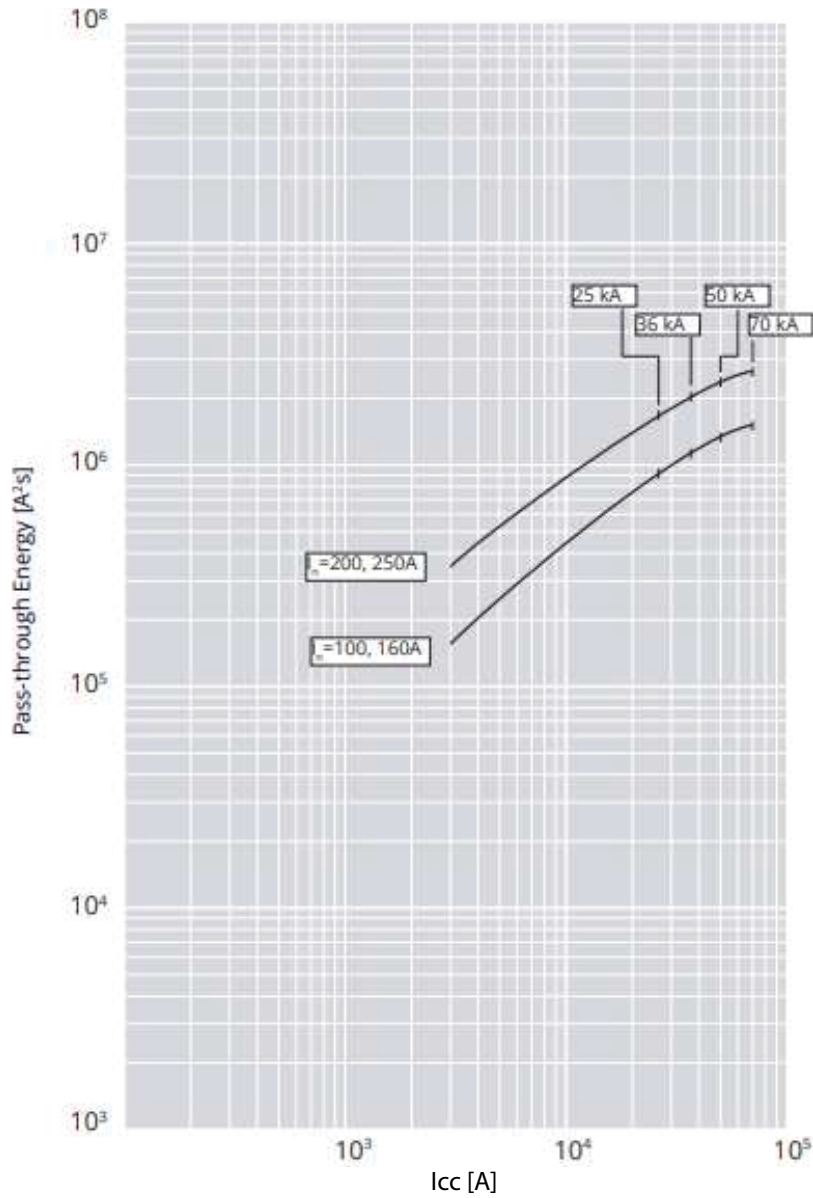

Icu = 25-36-50 kA I_{max} = 250 A 3-3P+N/2 U_e = 415 V~

Value	Description
I _{cc}	Short circuit current
I ² t (A ² s)	Pass-through specific energy

9. CURVES (continued)

■ **9.3 Cut-off peak current characteristic curve (kA)**

Update: 07/05/2018

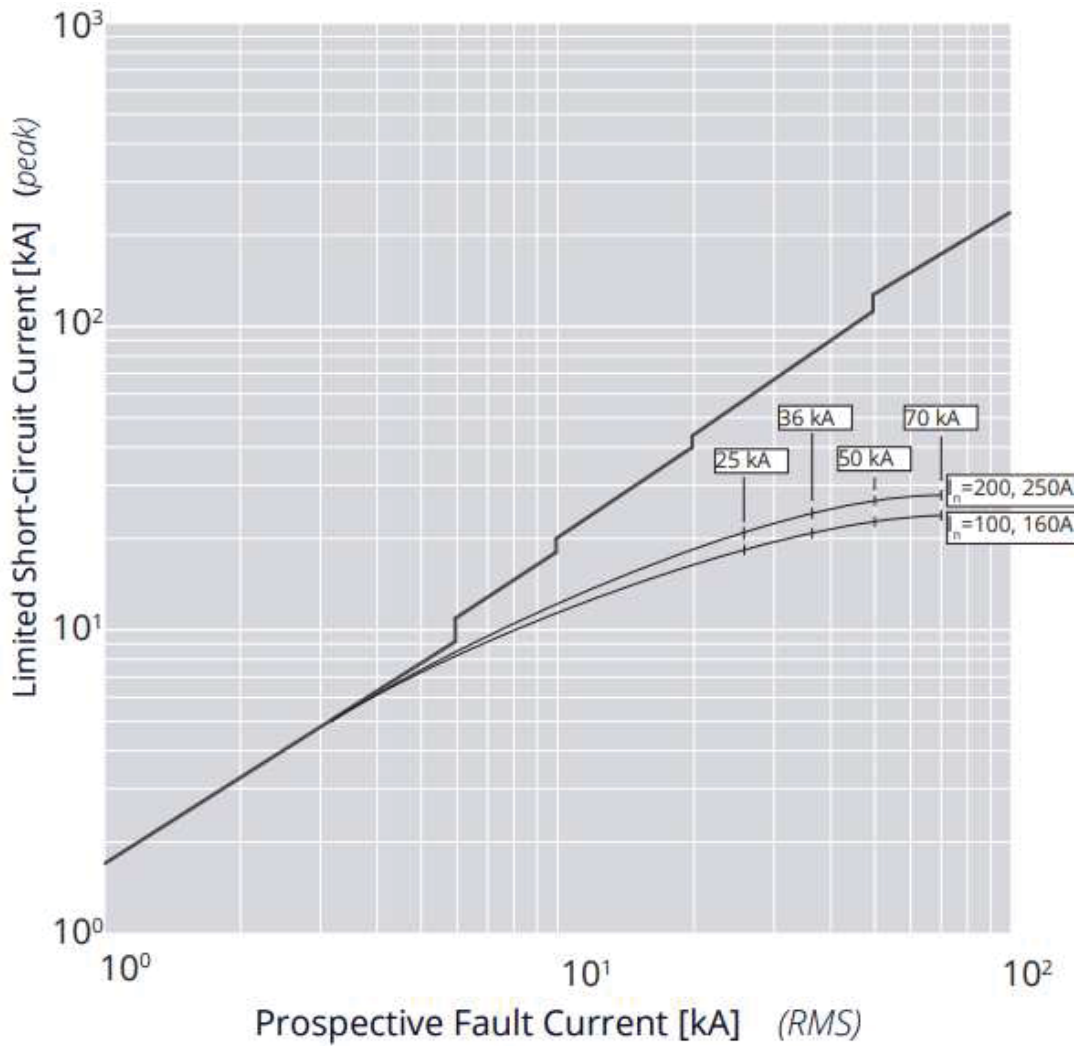

I_{cu} = 25-36-50 kA I_{max} = 250 A 3-3P+N/2 U_e = 415 V~

Value	Description
I _{cc}	Estimated short circuit symmetrical current (RMS value)
I _p	Maximum short circuit peak current

Megatiker M2 250 thermal magnetic circuit breakers

Megatiker MS2 250 trip-free switches

Cat.Nos:
T723B100 - T723B160 - T723B200 - T723B250 - T724B100
T724B160 - T724B200 - T724B250 - T723F100 - T723F160
T723F200 - T723F250 - T724F100 - T724F160 - T724F200
T724F250 - T723N100 - T723N160 - T723N200 - T723N250
T724N100 - T724N160 - T724N200 - T724N250- T723S250
T724S250

10. STANDARDS AND REGULATIONS

Megatiker range of product concerning circuit-breakers and trip-free switch exceed compliance with the IEC/EN standard 60947-2 and 60947-3 respectively. Certification available by IECEE CB-scheme or LOVAG Compliance scheme.

Megatiker range respects the European Directives:

RoHS: Compliance with the 2011/65/EU Directive (RoHS), as modified by the 2015/863/EU Delegated Directive, on the restriction of the use of certain hazardous substances in electrical and electronic equipment.

REACH: The substances identified as SVHC (Substances of Very High Concern) according to the REACH Regulation (1907/2006), if present in the products at a concentration above 0.1% weight by weight, are declared inside the European SCIP database. At the date of publication of this document none of the substance listed in the annex XIV is found in this product.

WEEE: WEEE Directive (2012/19/EU): the sale of this product includes a contribution to the appointed environmental bodies of each European country in charge of handling, at the end of their life, the products falling within the scope of the EU Directive on Electrical and Electronic Equipment Waste..

Packaging : Design and manufacture of packaging compliant with European Directive 94/62/CE.

For specific information, please contact BTicino support.

11. OTHER INFORMATION

XLPro Calcul: Calculation notes creation software, addressed to installers, design office and maintenance operators. Definition of the electrical characteristics of a low voltage installation in compliance with the applicable standards

XLPro³ Tool Selectivity and backup/ BTicino Selectivity and backup: Software dedicated to installers, panelbuilders and design offices. Definition of the selectivity and backup values of an association of electrical devices and obtention of the tripping curves of the selected products.

XLPro Panels: Distribution panel design software, addressed to panelbuilders and electrical panel designers. Design of the electrical distribution of the panel, production of electrical diagrams, establishment of products and overall costing of the project.

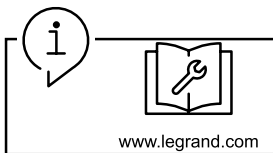

Workshop book: mounting informations, equipments, accessories and spare parts available on e-catalog.

Instruction sheet: detailed mounting procedures, available on e-catalog.

PEP: available on e-catalog.

For further technical information, please contact BTicino technical support.

Unless otherwise indicated, data reported in this document refers exclusively to test conditions according to product standards.

For different conditions of use of the product, inside electrical equipment or in any different installation context, refer to the regulatory requirements of the equipment, local regulations and design specifications of the system.