

LIVING NOW - KNX 3 in 1 flat thermostat black

Cat.No(s):KG4691F3KNX

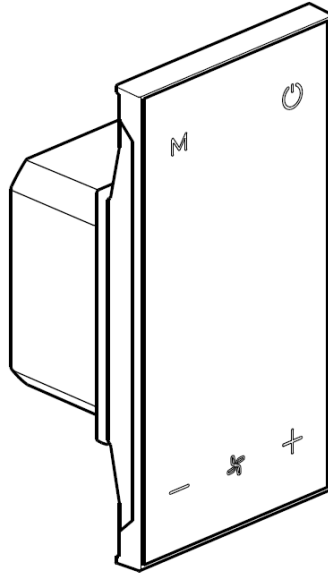

1. SUMMARY	3
2. TECHNICAL SPECIFICATIONS	3
3. DIMENSION AND STRUCTURAL DIAGRAM	4
3.1. DIMENSION DIAGRAM	4
3.2. STRUCTURAL DIAGRAM	4
3.3. INSTALLATION AND DISASSEMBLY INSTRUCTIONS	4
4. PARAMETER SETTING DESCRIPTION IN THE ETS	5
4.1. SUMMARY	5
4.2. GENERAL > GENERAL SETTING	5
4.3. INTERNAL SENSOR > MEASUREMENT SETTING	5
4.4. HVAC CONTROLLER > CONTROLLER SETTING	5
4.5. HVAC CONTROLLER > AC SETTING	6
4.5.1. HVAC controller > AC setting > Fan	7
4.5.2. HVAC controller > AC setting > Mode	8
4.5.3. HVAC controller > AC setting > Scene	9
4.6. HVAC CONTROLLER > FCU SETTING	10
4.6.1. HVAC controller > FCU setting > Heating control	11
4.6.2. HVAC controller > FCU setting > Cooling control	12
4.6.3. HVAC controller > FCU setting > Heating /Cooling control	13
4.6.4. HVAC controller > FCU setting > Fan	14
4.6.5. HVAC controller > FCU setting > Scene	16
4.7. HVAC CONTROLLER > VENTILATION SETTING	16
4.7.1. HVAC controller > Ventilation setting > Fan	17
4.7.2. HVAC controller > Ventilation setting > Scene	18

4.8. HVAC CONTROLLER > FLOOR HEATING SETTING..... 18
 4.8.1. HVAC controller > Floor heating setting> Scene..... 19

5. COMMUNICATION OBJECT 21

 5.1 "GENERAL" COMMUNICATION OBJECT 22

 5.2. " INTERNAL SENSOR" COMMUNICATION OBJECT 22

 5.3. "AC" COMMUNICATION OBJECT 22

 5.4. " VENTILATION" COMMUNICATION OBJECT 24

 5.5. " FLOOR HEATING" COMMUNICATION OBJECT 25

 5.6. " FCU" COMMUNICATION OBJECT 26

1. SUMMARY

LIVING NOW - KNX 3 in 1 flat thermostat black is used to display status and control a variety of KNX devices. Use the touch buttons on the panel to implement the preset functions. For example, send air conditioning control commands, scene control commands, and so on to control other devices on the KNX bus system.

LIVING NOW - KNX 3 in 1 flat thermostat black is mainly used in the smart home control system, using a wall-mounted installation.

The user manual describes detailed technical information of LIVING NOW - KNX 3 in 1 flat thermostat black, including installation and programming as well it shows usage integrating with application examples.

LIVING NOW - KNX 3 in 1 flat thermostat black can be connected to other EIB/KNX devices to make up the system via EIB/KNX BUS.

Engineering Tools Software (ETS) can be used to use and operate the system.

The main functions of the temperature control panel are summarized as follows:

- HVAC control
- Air Conditioning control and FCU function control
- Ventillation control
- Floor heating control
- Built-in temperature sensor
- Scene function

2. TECHNICAL SPECIFICATIONS

Power Supply	Operating Voltage	21-30V DC, via the KNX bus
	Current consumption, bus	<20mA/24V DC, <22mA/30V DC
	Power consumption, bus	<Max.300mW
Connections	KNX	Via bus connection terminal(red/black)
Temperature	Operation	+5 °C ... + 45 °C
	Storage	-25 °C ... + 55 °C
	Transport	- 25 °C ... + 70 °C
Environment	Humidity	<93%, except for dewing
Installation	Wall-mounted installation	
Size	44.7 x 86 x 30.2mm	
Weight	0.050KG	

3. DIMENSION AND STRUCTURAL DIAGRAM

■ 3.1.Dimension Diagram

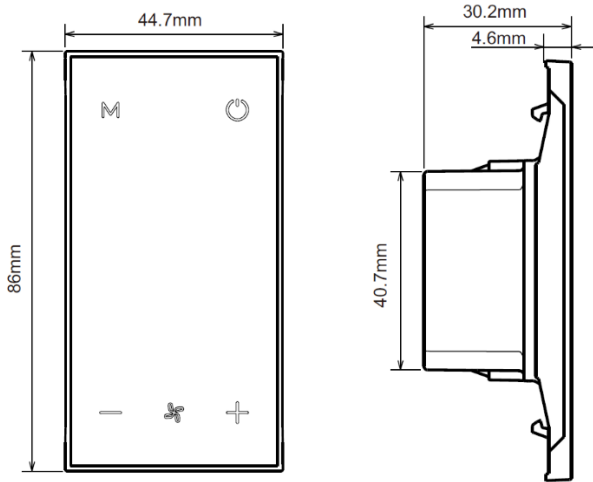

■ 3.2. Structural Diagram

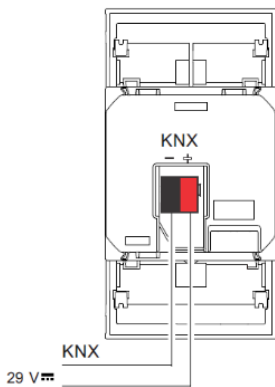
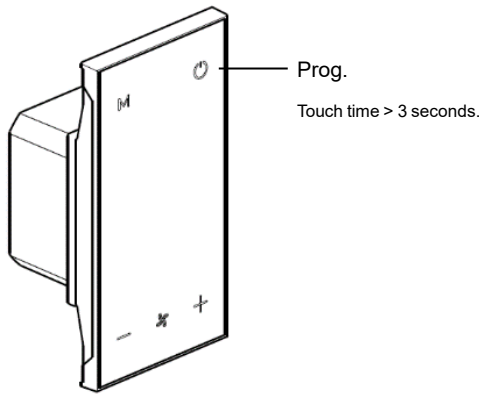

3. DIMENSION AND STRUCTURAL DIAGRAM (continues)

■ 3.3. Installation and Disassembly instructions

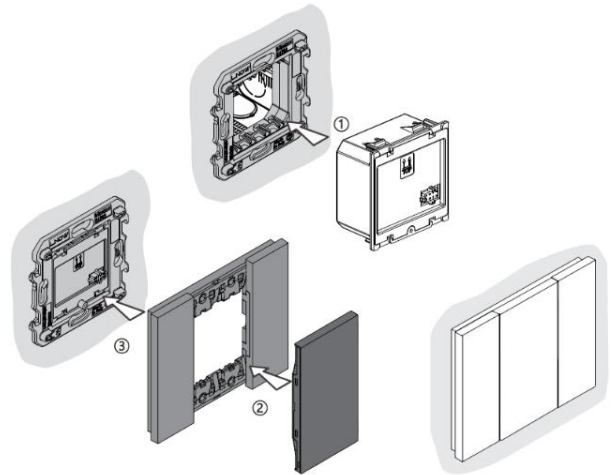

4. PARAMETER SETTING DESCRIPTION IN THE ETS

4.1. Summary

ETS configuration include backlight Settings for normal or standby working mode, touch volume Settings, Temperature calibration Settings, AC Settings, FCU Settings, Ventilation setting, Floor heating setting etc.

4.2. General > General setting

The "General setting" parameter setting interface is shown in Figure 4.1, It can configure the brightness of the backlight and the volume of the button when it is touched.

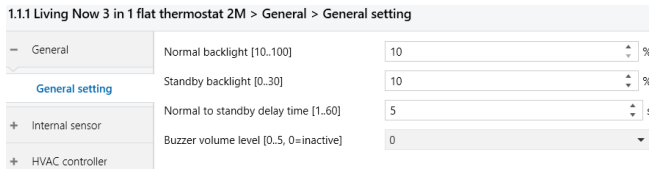

Figure 4.1 "General setting" parameter setting interface

Parameter "Normal backlight [10..100]%"

Set the backlight brightness level of the panel under normal day operation.

Options: 10 ... 100

Parameter "Standby backlight [0..30]%"

Set the backlight brightness level of the panel under normal operation at night.

Options: 0 ... 30

Parameter "Normal to standby delay time [1..60]s"

To set the delay time from normal mode to standby mode. The delay time starts from the last operation.

Options: 1 ... 60

Parameter "Buzzer volume level [0..5, 0=inactive]"

To set the volume for touch.

Options: 0 ... 5

4.3. Internal sensor > Measurement setting.

The "Measurement setting" parameter setting interface is shown in Figure 4.2, This interface can be configured, including temperature calibration, temperature value transmission, etc.

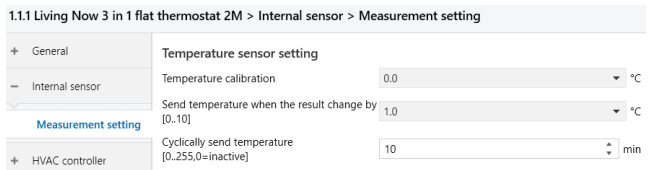

Figure 4.2" Measurement setting " parameter setting interface

Parameter "Temperature calibration"

This parameter for setting the temperature calibration value, that is, to calibrate the measured value of internal sensor to make it closer to the current ambient temperature.

4. PARAMETER SETTING DESCRIPTION IN THE ETS (continues)

Options:

-5.0 °C

...

0.0

...

5.0 °C

Parameter "Send temperature when the result change by [0..10]°C"

This parameter for setting when temperature turns to a certain value, send the actual temperature value to the bus.

Options: 0 ... 10

Parameter "Cyclically send temperature [0..255,0=inactive]min"

Setting the time for cyclically sending the temperature detection value to the bus.

Options: 0 ... 255, 0=inactive

4.4. HVAC controller > Controller setting

HVAC is mainly used to control the room temperature, automatically and optimally control the heating and cooling according to the use of the room or the needs of the occupants. Supports manually switching of heating/cooling control, support options for three-level fan speed and auto fan speed, four operation modes: comfortable, standby, economy and protection mode. The setting temperature supports absolute and relative settings, as well as adjustable temperature range settings. Supports 2-point and PI control. The "Controller setting" parameter setting interface is shown in Figure 4.3

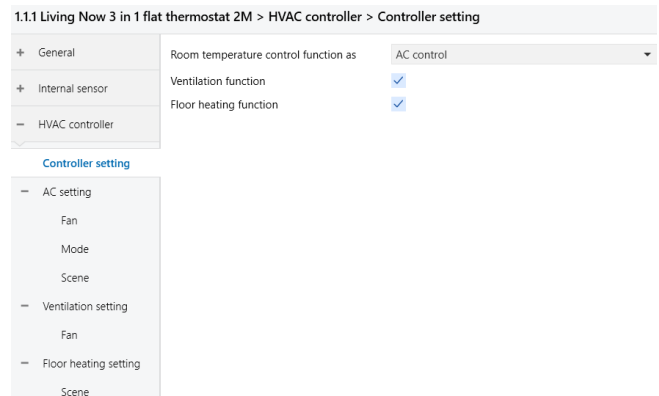

Figure 4.3 "Controller setting" parameter setting interface

4. PARAMETER SETTING DESCRIPTION IN THE ETS (continues)

Parameter "Room temperature control function as"

Temperature control function selection.

Options:

- Disable
- FCU control
- AC control

Parameter "Ventilation function"

Whether the Ventilation function is enabled.

Parameter "Floor heating function"

Whether the Floor heating function is enabled.

■ 4.5. HVAC controller > AC setting

Parameter setting interface "AC setting" shown as Figure 4.4, It is mainly used for setting related parameters of AC setting. Before setting this interface "Room temperature control function as" set as "AC control" on the "Controller setting" setting interface.

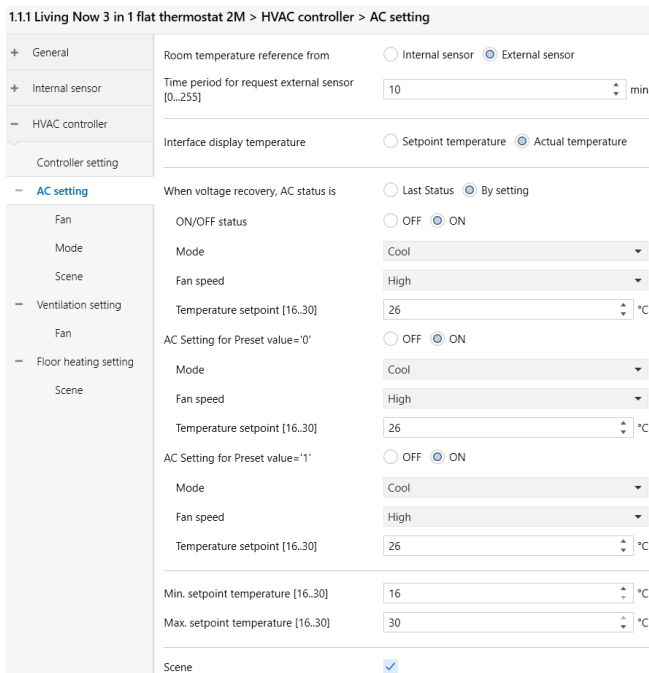

Figure 4.4 HVAC controller > AC setting Parameter setting interface

Parameter "Room temperature reference from"

Setting the source of room temperature.

Options:

- Internal sensor
- External sensor

Parameter "Time period for request external sensor [0..255]min"

This parameter for setting the period for request external sensor.

4. PARAMETER SETTING DESCRIPTION IN THE ETS (continues)

Options: 0 ... 255

Parameter "Interface display temperature"

Set the temperature under which function is displayed in the default state.

Options:

- Setpoint temperature
- Actual temperature

Parameter "When voltage recovery, AC status is"

Setting AC status of HVAC interface after voltage recovery.

Options:

- Last Status
- By setting

When "By setting" be chosen Set the following parameters

Parameter "ON/OFF status"

Setting "ON/OFF status" of AC after voltage recovery.

Options:

- OFF
- ON

Parameter "Mode"

Setting "mode" of AC after voltage recovery.

Options:

- Auto
- Cool
- Heat
- Dry
- Fan

Parameter "Fan speed"

Setting "Fan speed" of AC after voltage recovery.

Options:

- Low
- Medium
- High

Parameter "Temperature setpoint [16..30]°C"

Setting "Temperature setpoint" of AC after voltage recovery.

Options: 16 ... 30

Parameter "AC Setting for Preset value='0'"

Setting the preset output, when the communication object "Preset 1Bit" of AC receive "0"

4. PARAMETER SETTING DESCRIPTION IN THE ETS (continues)**Parameter "Mode"**

Setting "mode" of AC after voltage recovery.

Options:

Auto
Cool
Heat
Dry
Fan

Parameter "Fan speed"

Setting "Fan speed" of AC after voltage recovery.

Options:

Low
Medium
High

Parameter "Temperature setpoint [16..30]°C"

Setting "Temperature setpoint" of AC after voltage recovery.

Options: 16 ... 30

Parameter "AC Setting for Preset value='1'"

Setting the preset output when the communication object "Preset 1Bit" of AC receive "1".

Parameter "Mode"

Setting "Mode" of AC after voltage recovery.

Options:

Auto
Cool
Heat
Dry
Fan

Parameter "Fan speed"

Setting "Fan speed" of AC after voltage recovery.

Options:

Low
Medium
High

Parameter "Temperature setpoint [16..30]°C"

Setting "Temperature setpoint" of AC after voltage recovery.

Options: 16 ... 30

Parameter "Min. setpoint temperature [16..30]°C"

Setting to limit the adjustable range of the setting minimum temperature. If the setting temperature beyond the limited range, then will output the limited temperature.

Options: 16 ... 30

4. PARAMETER SETTING DESCRIPTION IN THE ETS (continues)**Parameter "Max. setpoint temperature [16..30]°C"**

Setting to limit the adjustable range of the setting maximum temperature. If the setting temperature beyond the limited range, then will output the limited temperature.

Options: 16 ... 30

Parameter "Scene"

Setting for scene functions of AC, a total of 4 scenes are available for setting.

■ 4.5.1. HVAC controller > AC setting > Fan

Parameter setting interface "Fan" of "AC setting" shown as Figure 4.5, It is mainly for setting related parameters of Fan, such as "Output value for Fan speed". "Status feedback for Fan speed" and so on.

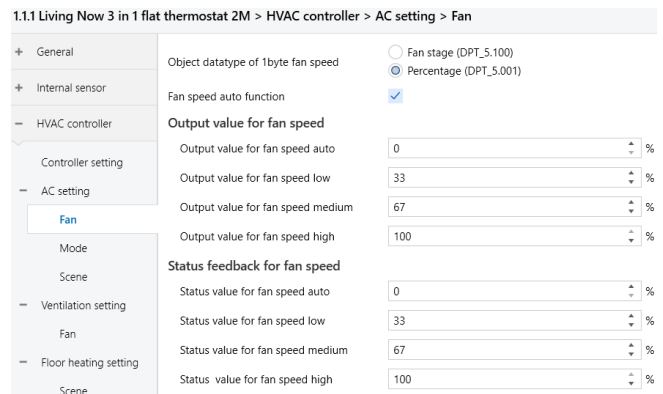

Figure 4.5 HVAC controller > AC setting > Fan Parameter setting interface

Parameter "Object datatype of 1byte fan speed"

This parameter for setting the object type of fan speed control.

Options:

Fan stage (DPT_5.100)
Percentage (DPT_5.001)

Parameter "Fan speed auto function"

This parameter for Set whether to enable the automatic wind speed function.

Output value for fan speed

Setting the switching value that sent by each fan speed.

Parameter "Output value for fan speed auto"

Setting the switching value that sent by fan speed auto.

Options: 0 ... 255

when "Object datatype" is "Fan stage (DPT_5.100)"

Options: 0% ... 100%

when "Object datatype" is "Percentage (DPT_5.001)"

4. PARAMETER SETTING DESCRIPTION IN THE ETS (continues)

Parameter "Output value for fan speed low"

Setting the switching value that sent by fan speed low.

Options: 0 ... 255

when "Object datatype" is "Fan stage (DPT_5.100)"

Options: 0% ... 100%

when "Object datatype" is "Percentage (DPT_5.001)"

Parameter "Output value for fan speed medium"

Setting the switching value that sent by fan speed medium.

Options: 0 ... 255

when "Object datatype" is "Fan stage (DPT_5.100)"

Options: 0% ... 100%

when "Object datatype" is "Percentage (DPT_5.001)"

Parameter "Output value for fan speed high"

Setting the switching value that sent by fan speed medium.

Options: 0 ... 255

when "Object datatype" is "Fan stage (DPT_5.100)"

Options: 0% ... 100%

when "Object datatype" is "Percentage (DPT_5.001)"

Status feedback for fan speed

For setting the status feedback value of each fan speed

Parameter "Status value for fan speed auto"

Setting the feedback value fan speed auto.

Options: 0 ... 255

when "Object datatype" is "Fan stage (DPT_5.100)"

Options: 0% ... 100%

when "Object datatype" is "Percentage (DPT_5.001)"

Parameter "Status value for fan speed low"

Setting the feedback value fan speed low.

Options: 0 ... 255

when "Object datatype" is "Fan stage (DPT_5.100)"

Options: 0% ... 100%

when "Object datatype" is "Percentage (DPT_5.001)"

Parameter "Status value for fan speed medium"

Setting the feedback value fan speed medium.

Options: 0 ... 255

when "Object datatype" is "Fan stage (DPT_5.100)"

Options: 0% ... 100%

when "Object datatype" is "Percentage (DPT_5.001)"

Parameter "Status value for fan speed high"

Setting the feedback value fan speed high.

Options: 0 ... 255

when "Object datatype" is "Fan stage (DPT_5.100)"

Options: 0% ... 100%

4. PARAMETER SETTING DESCRIPTION IN THE ETS (continues)

when "Object datatype" is "Percentage (DPT_5.001)"

■ 4.5.2.HVAC controller > AC setting > Mode

Parameter setting interface "HVAC controller > AC setting > Mode" shown as Figure 4.6, It is mainly for setting related parameters of AC mode, such as Auto mode, Heat mode, Cool mode and so on.

1.1.1 Living Now 3 in 1 flat thermostat 2M > HVAC controller > AC setting > Mode

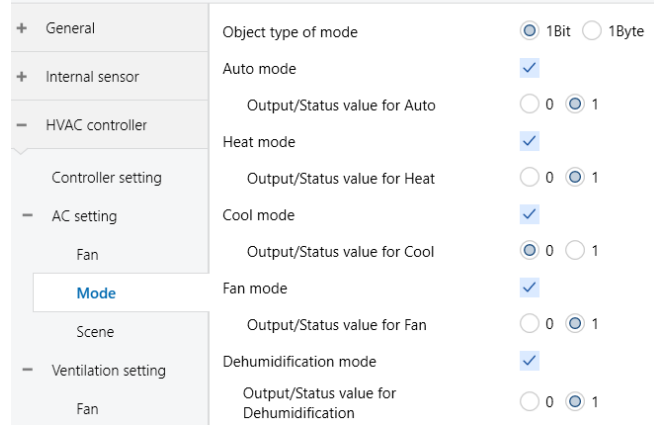

Figure 4.6 HVAC controller > AC setting > Mode

Parameter "Object type of mode"

This parameter for Select the type of object output.

Options:

1Bit

1Byte

when "Object datatype"1Bit

Select the working mode to be activated

Options:

Auto mode

Heat mode

Cool mode

Fan mode

Dehumidification mode

Parameter "Auto mode"

Setting the switching value that sent by Auto mode.

Options: 0 or 1 (off or on)

Parameter "Heat mode"

Setting the switching value that sent by Heat mode.

Options: 0 or 1 (off or on)

Parameter "Cool mode"

Setting the switching value that sent by Cool mode.

Options: 0 or 1 (off or on)

4. PARAMETER SETTING DESCRIPTION IN THE ETS (continues)

Parameter “fan mode”

Setting the switching value that sent by fan mode.

Options: 0 or 1 (off or on)

Parameter “Dehumidification mode”

Setting the switching value that sent by Dehumidification mode.

Options: 0 or 1 (off or on)

when “Object datatype”1Byte

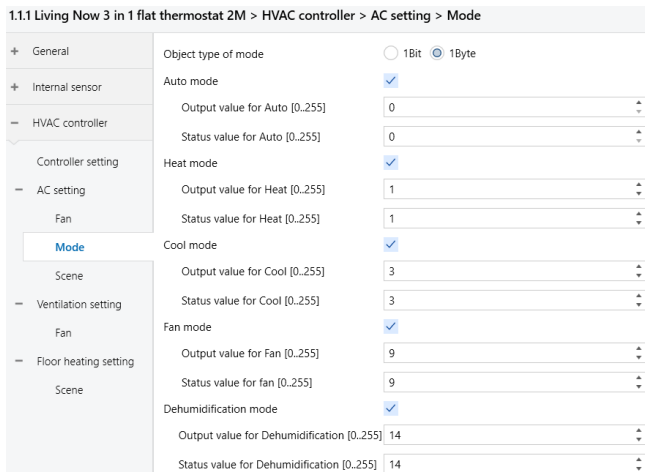

Figure 4.7 HVAC controller>AC setting>Mode

Auto mode

Parameter “Output value for Auto [0..255]”

Setting the switching value that sent by Auto mode.

Options: 0 ... 255

Parameter “Status value for Auto [0..255]”

Setting the status feedback value of Auto mode.

Options: 0 ... 255

Heat mode

Parameter “Output value for Heat [0..255]”

Setting the switching value that sent by Heat mode.

Options: 0 ... 255

Parameter “Status value for Heat [0..255]”

Setting the status feedback value of Status value for Heat.

Options: 0 ... 255

Cool mode

Parameter “Output value for Cool [0..255]”

Setting the switching value that sent by Output value for Cool.

Options: 0 ... 255

Parameter “Status value for Cool [0..255]”

Setting the status feedback value of Status value for Cool.

Options: 0 ... 255

4. PARAMETER SETTING DESCRIPTION IN THE ETS (continues)

Fan mode

Parameter “Output value for Fan [0..255]”

Setting the switching value that sent by Output value for Fan.

Options: 0 ... 255

Parameter “Status value for Fan [0.255]”

Setting the status feedback value of Status value for Fan.

Options: 0 ... 255

Dehumidification mode

Parameter “Output value for Dehumidification [0..255]”

Setting the switching value that sent by Dehumidification mode.

Options: 0 ... 255

Parameter “Status value for Dehumidification [0.255]”

Setting the status feedback value of Dehumidification mode.

Options: 0 ... 255

■ 4.5.3. HVAC controller > AC setting > Scene

Parameter setting interface “HVAC controller > AC setting > Scene” shown as Figure 4.8, It is mainly for setting related parameters of AC scene.

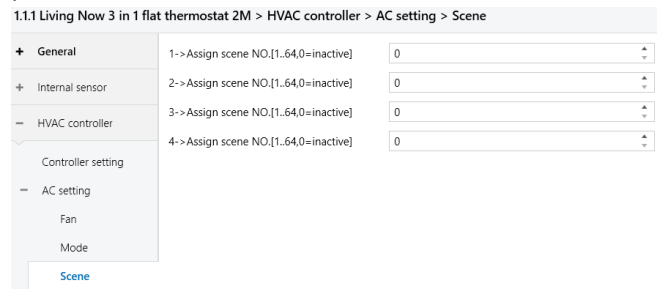

Figure 4.8 HVAC controller>AC setting>Scene

Parameter “1->Assign scene NO. [1..64,0=inactive]”

Setting scene number.

Options: 0 ... 64, 0=inactive

Parameter “2->Assign scene NO. [1..64,0=inactive]”

Setting scene number.

Options: 0 ... 64, 0=inactive

Parameter “3->Assign scene NO. [1..64,0=inactive]”

Setting scene number.

Options: 0 ... 64, 0=inactive

Parameter “4->Assign scene NO. [1..64,0=inactive]”

Setting scene number.

Options: 0 ... 64, 0=inactive

4. PARAMETER SETTING DESCRIPTION IN THE ETS (continues)

■ 4.6. HVAC controller > FCU setting

Parameter setting interface "HVAC controller >FCU setting" shown as Figure 4.9, it is mainly for setting related parameters of FCU, such as Work mode. Room temperature control mode and so on. Before setting this interface "Room temperature control function as" set as "FCU control" on the "Controller setting" setting interface.

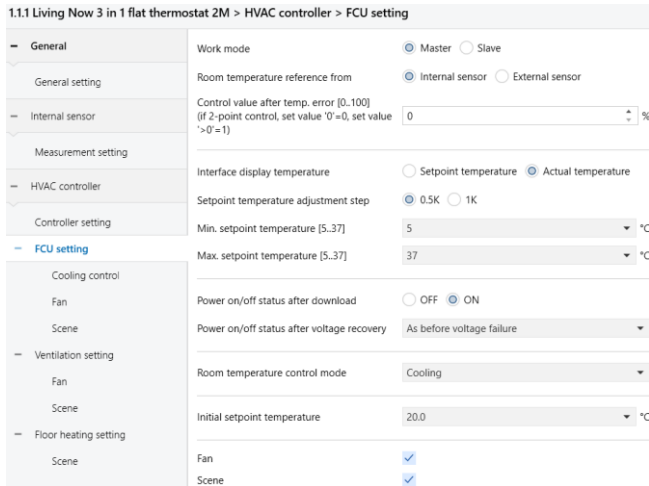

Figure 4.9 HVAC controller >FCU setting

Parameter "Work mode"

Choice the FCU Work mode.

Options:

- Master
- Slave

Parameter "Room temperature reference from"

Setting room temperature of FCU from external or internal sensor detection.

Options:

- Internal sensor
- External sensor

When parameter "Room temperature reference from" set as "External sensor", set parameters shown as below.



Parameter "Period for request external sensor [0..255]min"

This parameter for setting the period for read request external sensor.

Options: 0 ... 255

Parameter "Control value after temp. error [0..100] (if 2-point control, set value '0'=0, set value '>0'=1)"

4. PARAMETER SETTING DESCRIPTION IN THE ETS (continues)

Setting Control value of FCU when temperature detection wrong.

Options: 0% ... 100%

After the temperature is powered on, an error message is returned. If the device is a two-pipe device, the switch is ON/OFF, and the PI algorithm controls "set value".

Parameter "Interface display temperature"

Setting which show on the device.

Options:

- Setpoint temperature
- Actual temperature

Parameter "Setpoint temperature adjustment step"

Setting the temperature step value

Options:

- 0.5K
- 1K

Parameter "Min. setpoint temperature [5..37]°C"

Parameter "Max. setpoint temperature [5..37]°C"

These two parameters setting the adjustment range for limiting the setting temperature. The setting minimum value should be less than the maximum value.

If the setting temperature beyond the range, then output the limited value.

Options: 5 ... 37

Parameter "Power on/off status after download"

Setting for the power on/off status of FCU interface after application downloaded.

Options

- OFF
- ON

Parameter "Power on/off status after voltage recovery"

Setting for the power on/off status of floor heating interface after the bus recovery.

Options:

- OFF
- ON
- As before voltage failure

Parameter "Room temperature control mode"

This parameter for setting HVAC control mode.

Options:

- Heating
- Cooling
- Heating and Cooling

4. PARAMETER SETTING DESCRIPTION IN THE ETS (continues)

When parameter "Room temperature control mode" set as "Heating", set parameters shown as below.

Low temperature protection when power off

Temperature °C

Room temperature control mode

Parameter "Temperature"

Setting for the low temperature protection when power off.

Options: 5°C ... 10°C

When parameter "Room temperature control mode" set as "Heating and Cooling", set parameters shown as below.

Low temperature protection when power off

Temperature °C

Room temperature control mode

Heating/Cooling switchover

Heating/Cooling status after download Heating Cooling

Heating/Cooling status after voltage recovery

Room temperature control system 2 pipes system 4 pipes system

Parameter "Temperature"

Setting for the low temperature protection when power off.

Options: 5°C ... 10°C

Parameter "Heating/Cooling switchover"

Setting for the heating/Cooling switchover.

Options:

- Only via button
- Only via object
- Via both button and object
- Automatic changeover

Parameter "Heating/Cooling status after download"

Setting for the heating/Cooling status of FCU interface after application downloaded.

Options:

- Heating
- Cooling

Parameter "Heating/Cooling status after voltage recovery"

Setting for the heating/Cooling status of FCU interface after the bus recovery.

Options:

- Heating
- Cooling
- As before voltage failure

4. PARAMETER SETTING DESCRIPTION IN THE ETS (continues)

Parameter "Room temperature control system"

Setting for the room temperature control system.

Options:

- 2 pipes system
- 4 pipes system

Parameter "Initial setpoint temperature"

Setting for the initial setpoint temperature displayed on the screen for FCU power on.

Options: 10.0°C ... 35.0°C

Parameter "Fan"

Setting for enable fan function.

Parameter "Scene"

Setting for enable Scene function.

4.6.1. HVAC controller >FCU setting> Heating control

Parameter setting interface "HVAC controller >FCU setting > Heating control" shown as Figure 4.91, it is mainly for setting related parameters of heating control, Before setting this interface "Room temperature control mode" set as "Heating" "on the "FCU setting" setting interface.

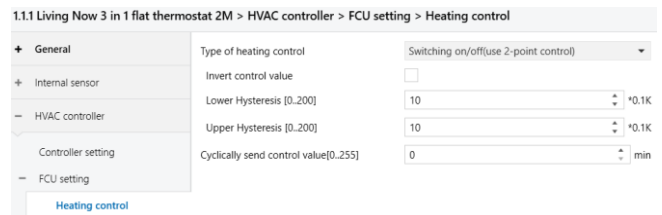

Figure 4.91 HVAC controller >FCU setting> Heating control

Parameter "Type of heating control"

Setting for heating mode use which type to control.

Options:

- Switching on/off (use 2-point control)
- Switching PWM (use PI control)
- Continuous control (use PI control)

Parameter "Invert control value"

Set to enable Invert control value.

Parameter "Type of heating control" choose "Switching on/off (use 2-point control)" set below:

Type of heating control

Invert control value

Lower Hysteresis [0..200] *0.1K

Upper Hysteresis [0..200] *0.1K

Cyclically send control value[0..255] min

4. PARAMETER SETTING DESCRIPTION IN THE ETS (continues)

Parameter “Lower Hysteresis [0..200]*0.1K”

Parameter “Upper Hysteresis [0..200]*0.1K”

These two parameters for setting the lower/upper hysteresis temperature in HVAC Heating.

When the actual temperature(T) > the setting temperature + the upper hysteresis temperature, then will stop heating.

When the actual temperature(T) < the setting temperature - the lower hysteresis temperature, then will start heating.

Options: 0 ... 200

Parameter “Cyclically send control value[0..255]min”

This parameter sets the time period for cyclically sending control values to the bus.

Options: 0 ... 255

Parameter “Type of heating control” choose “Switching PWM (use PI control)” set below:

Type of heating control	Switching PWM(use PI control)
Invert control value	<input checked="" type="checkbox"/>
PWM cycle time [1..255]	15 min
Heating speed	Hot water heating(5K/150min)
Cyclically send control value[0..255]	0 min

Parameter “PWM cycle time [1..255]min”

For setting the period of the control object cycle to send the switch value, the object sends the switch value according to the duty cycle of the control value.

Options: 1 ... 255

Parameter “Heating speed”

Setting the response speed of the heating PI controller.

Different response speeds apply to different environments.

Options:

- Hot water heating(5K/150min)
- Underfloor heating(5K/240min)
- Electrical heating(4K/100min)
- Split unit(4K/90min)
- Fan coil unit(4K/90min)
- User defined

Parameter “Type of heating control” choose “Continuous control(use PI control)” set below:

Type of heating control	Continuous control(use PI control)
Invert control value	<input checked="" type="checkbox"/>
Heating speed	Hot water heating(5K/150min)
Send control value on change by [0..100,0=inactive]	4 %
Cyclically send control value[0..255]	0 min

Parameter “Heating speed”

4. PARAMETER SETTING DESCRIPTION IN THE ETS (continues)

Setting the response speed of the heating PI controller.

Different response speeds apply to different environments.

Options:

- Hot water heating(5K/150min)
- Underfloor heating(5K/240min)
- Electrical heating(4K/100min)
- Split unit(4K/90min)
- Fan coil unit(4K/90min)
- User defined.

Parameter “Send control value on change by [0..100,0=inactive]%”

This parameter is visible when control type is “Continuous control (use PI control)”, for setting the changing value of the control value to be sent to the bus.

Options: 0 ... 100, 0=inactive

4.6.2. HVAC controller > FCU setting > Cooling control

Parameter setting interface “HVAC controller >FCU setting>Cooling control” shown as Figure 4.92, it is mainly for setting related parameters of cooling control, Before setting this interface “Room temperature control mode” set as “Cooling” on the “FCU setting” setting interface.

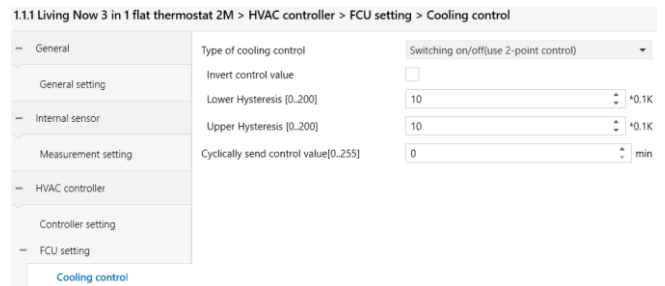

Figure 4.92 HVAC controller >FCU setting>Cooling control

Parameter “Type of cooling control”

Setting for cooling mode use which type to control.

Options:

- Switching on/off (use 2-point control)
- Switching PWM (use PI control)
- Continuous control (use PI control)

Parameter “Invert control value”

Set to enable Invert control value.

Parameter “Type of cooling control” choose “Switching on/off (use 2-point control)” set below:

Type of cooling control	Switching on/off(use 2-point control)
Invert control value	<input checked="" type="checkbox"/>
Lower Hysteresis [0..200]	10 *0.1K
Upper Hysteresis [0..200]	10 *0.1K
Cyclically send control value[0..255]	0 min

4. PARAMETER SETTING DESCRIPTION IN THE ETS (continues)**Parameter "Lower Hysteresis [0..200]*0.1K"****Parameter "Upper Hysteresis [0..200]*0.1K"**

These two parameters for setting the lower/upper hysteresis temperature in HVAC Cooling.

When the actual temperature (T) < the setting temperature - the lower hysteresis temperature, then will stop cooling.

When the actual temperature (T) > the setting temperature + the upper hysteresis temperature, then will start cooling.

Options: 0 ... 200

Parameter "Cyclically send control value[0..255]min"

This parameter sets the time period for cyclically sending control values to the bus.

Options: 0 ... 255

Parameter "Type of heating control" choose "Switching PWM (use PI control)" set below:

Type of cooling control	Switching PWM(use PI control)
Invert control value	<input checked="" type="checkbox"/>
PWM cycle time [1..255]	15 min
Cooling speed	Cooling ceiling(5K/240min)
Cyclically send control value[0..255]	0 min

Parameter "PWM cycle time [1..255]min"

For setting the period of the control object cycle to send the switch value, the object sends the switch value according to the duty cycle of the control value.

Options: 1 ... 255

Parameter "Cooling speed"

Setting the response speed of the cooling PI controller.

Different response speeds apply to different environments.

Options:

Cooling ceiling(5K/240min)

Split unit(4K/90min)

User defined.

Fan coil unit(4K/90min)

Parameter "Cyclically send control value[0..255]min"

This is the sending cycle time of the control value, in minutes.

Options: 0 ... 255

Parameter "Type of heating control" choose "Continuous control (use PI control)" set below:

Type of cooling control	Continuous control(use PI control)
Invert control value	<input checked="" type="checkbox"/>
Cooling speed	Cooling ceiling(5K/240min)
Send control value on change by [0..100,0=inactive]	4 %
Cyclically send control value[0..255]	0 min

4. PARAMETER SETTING DESCRIPTION IN THE ETS (continues)**Parameter "Cooling speed"**

Setting the response speed of the cooling PI controller.

Different response speeds apply to different environments.

Options:

Cooling ceiling(5K/240min)

Split unit(4K/90min)

User defined.

Fan coil unit(4K/90min)

Parameter "Send control value on change by [0..100,0=inactive]%"

This parameter is visible when control type is "Continuous control (use PI control)", for setting the changing value of the control value to be sent to the bus.

Options: 0 ... 100, 0=inactive

Parameter "Cyclically send control value [0..255]min"

This parameter sets the time period for cyclically sending control values to the bus.

Options: 0 ... 255

4.6.3. HVAC controller > FCU setting > Heating/Cooling control

Parameter setting interface "HVAC controller > FCU setting > Heating/Cooling control" shown as Figure 4.10, it is mainly for setting related parameters of heating and cooling control, Before setting this interface "Room temperature control mode" set as "Heating/Cooling control" on the "FCU setting" setting interface.

The parameter settings are the same as 4.6.1 and 4.6.2

1.1.1 Living Now 3 in 1 flat thermostat 2M > HVAC controller > FCU setting > Heating/Cooling control

+ General	Type of heating control	Switching PWM(use PI control)
+ Internal sensor	Invert control value	<input checked="" type="checkbox"/>
- HVAC controller	PWM cycle time [1..255]	15 min
Controller setting	Heating speed	Hot water heating(5K/150min)
- FCU setting	Type of cooling control	Continuous control(use PI control)
Heating/Cooling control	Invert control value	<input checked="" type="checkbox"/>
Fan	Cooling speed	Cooling ceiling(5K/240min)
Scene	Send control value on change by [0..100,0=inactive]	4 %
+ Ventilation setting	Cyclically send control value[0..255]	0 min
+ Floor heating setting		

Figure 4.10 HVAC controller > FCU setting > Heating /Cooling control

4. PARAMETER SETTING DESCRIPTION IN THE ETS (continues)

4.6.4. HVAC controller > FCU setting > Fan

Parameter setting interface “HVAC controller > FCU setting > Fan” shown as Figure 4.11, it is mainly for setting related parameters of Fan, such as “Output value for Fan speed”.

“Status feedback for Fan speed” and so on.

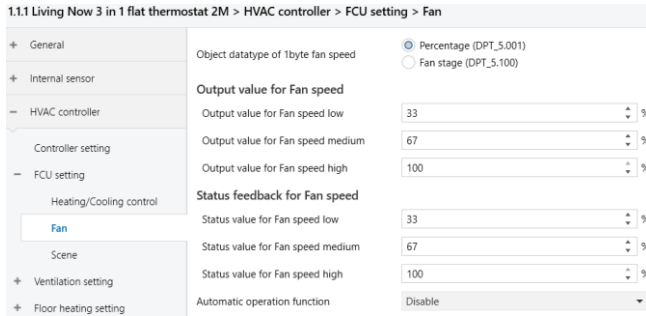

Figure 4.11 HVAC controller > FCU setting > Fan

Parameter “Object datatype of 1byte fan speed”

This parameter setting for the object datatype of 1byte fan speed.

Options:

Percentage (DPT_5.001)

Fan stage (DPT_5.100)

Output value for Fan speed

Parameter “Output value for Fan speed low”

Parameter “Output value for Fan speed medium”

Parameter “Output value for Fan speed high”

These parameters setting the switching value that sent by each fan speed.

Options:

1% ... 100%

(“Object datatype of 1byte fan speed” set as “Percentage (DPT_5.001)”)

1 ... 255

(“Object datatype of 1byte fan speed” set as “Fan stage (DPT_5.100)”)

Status feedback for Fan speed”

Parameter “Status value for Fan speed low”

Parameter “Status value for Fan speed medium”

Parameter “Status value for Fan speed high”

These parameters are setting for the status feedback value of each fan speed. The device will update and display the fan speed according to the feedback value.

Options:

1% ...100%

(“Object datatype of 1byte fan speed “set as” Percentage

4. PARAMETER SETTING DESCRIPTION IN THE ETS (continues)

(DPT_5.001)”)

1 ... 255

(“Object datatype of 1byte fan speed “set as” Fan stage (DPT_5.100)”)

Parameter “Automatic operation function”

Setting for Automatic operation function.

Options:

Disable

Local controller

External controller

Parameter “Automatic operation function” set as “Local controller”, set below:

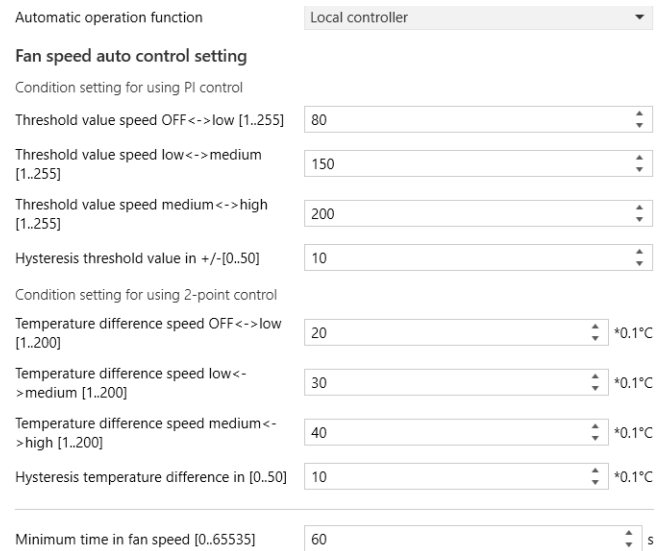

Fan speed auto control setting

Condition setting for using PI control.

Parameter “Threshold value speed OFF<->low [1..255]”

Define threshold value for off-fan and low-level fan speeds,

Options: 1 ... 255

If the control value is greater than or equal to this setting threshold value, low-level fan speed will start running; if the control value is less than this setting threshold value, the fan will be turned off.

Parameter “Threshold value speed low<->medium [1..255]”

Define the threshold value for switching the fan speed to medium fan speed, if the control value is greater than or equal to this setting threshold, the medium fan speed will start running.

Options: 1 ... 255

4. PARAMETER SETTING DESCRIPTION IN THE ETS (continues)**Parameter "Threshold value speed medium<->high [1..255]"**

Define the threshold for switching the fan speed to high fan speed, if the control value is higher or equal than this setting threshold, the high fan speed will start running.

Options: 1 ... 255

Threshold value speed OFF<->low [1..255]	80
Threshold value speed low<->medium [1..255]	150
Threshold value speed medium<->high [1..255]	200

If the parameters are set as the picture above, here is the functioning:

If the control value sent is:

- Between 0 and 80, the fan speed will be off
- Between 80 and 150, the fan speed will be Low
- Between 150 and 200, the fan speed will be Medium
- Higher than 200, the fan speed will be High

Parameter "Hysteresis threshold value in +/- [0..50]"

This parameter is for setting the hysteresis value of the threshold value, which can avoid the unnecessary action of the fan when the control value fluctuates near the threshold. If value is 0, no hysteresis. Fan switch to speed once control value higher than threshold value:

Options: 0 ... 50

Suppose that hysteresis value is 10 and the threshold is 50, then the upper limit threshold 60 (Threshold value+Hysteresis value) and the lower limit threshold 40 (Threshold value-Hysteresis value). When the control value is between 40 ~60, fan action will not be caused, and the previous status will still be maintained. Only less than 40 or higher or equal than 60 will change the running status of the fan.

Condition setting for using 2-point control**Parameter "Temperature difference speed OFF<->low [1..200]*0.1°C"**

This parameter is for setting the temperature difference between off-fan and low-level fan speeds.

Options: 1 ... 200

If the temperature difference is higher or equal than to this setting temperature difference, low-level fan speed will start running; if less than this setting temperature difference, the fan will be turned off.

4. PARAMETER SETTING DESCRIPTION IN THE ETS (continues)**Parameter "Temperature difference speed low<->medium [1..200]*0.1°C"**

Define the temperature difference for switching the fan speed to medium fan speed, if the control value is higher or equal than this setting temperature difference, the medium fan speed will start running.

Options: 1 ... 200

Parameter "Temperature difference speed medium<->high [1..200]*0.1°C"

Define the temperature difference for switching the fan speed to high fan speed, if the control value is higher or equal than this setting temperature difference, the high fan speed will start running.

Options: 1 ... 200

Parameter "Hysteresis temperature difference in [0..50]*0.1°C"

This parameter is for setting the hysteresis value of the temperature difference, which can avoid the unnecessary action of the fan when the control value fluctuates near the temperature difference.

Options: 0 ... 50

If value is 0, no hysteresis. Fan switch to speed once control value greater than temperature difference.

Suppose that hysteresis value is 0.5°C and the temperature difference is 1°C, then the upper limit temperature difference 1.5°C (Temperature difference+Hysteresis value) and the lower limit temperature difference 0.5°C (Temperature difference-Hysteresis value). When the control value is between 0.5°C ~1.5°C, fan action will not be caused, and the previous status will still be maintained. Only less than 0.5°C or higher or equal than 1.5°C will change the running status of the fan.

Parameter "Minimum time in fan speed [0..65535]s"

Defines the residence time of the fan from the current fan speed to a higher fan speed or lower fan speed, that is, the minimum time for a fan speed operation.

If you need to switch to another fan speed, you need to wait for this period before switching.

If the current fan speed has been running long enough, the fan speed can be changed quickly.

Options: 0 ... 65535

0: there is no minimum running time, but the delay switching time of fan speed still needs to be considered.

4. PARAMETER SETTING DESCRIPTION IN THE ETS (continues)

■ 4.6.5. HVAC controller > FCU setting > Scene

Parameter setting interface "HVAC controller > FCU setting > Scene" shown as Figure 4.12, it is mainly for setting related parameters of scene control.

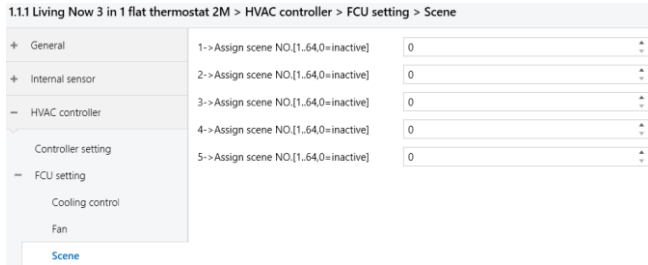

Figure 4.12 HVAC controller > FCU setting > Scene

Parameter "1->Assign scene NO. [1..64,0=inactive]"

Parameter "2->Assign scene NO. [1..64,0=inactive]"

Parameter "3->Assign scene NO. [1..64,0=inactive]"

Parameter "4->Assign scene NO. [1..64,0=inactive]"

Parameter "5->Assign scene NO. [1..64,0=inactive]"

These parameters setting for the scene number.

Options: 0 ... 64, 0=inactive

When these parameters not zero, set the parameters shown as below.



Parameter "ON/OFF status"

This parameter for setting on/off status of FCU, when scene recall.

Options:

OFF

ON

Unchange

Parameter "Temperature"

This parameter set the status of setpoint temperature.

Options:

5°C

...

37°C

Unchange

■ 4.7. HVAC controller > Ventilation setting

Parameter setting interface "HVAC controller > Ventilation setting" shown as Figure 4.13, it is mainly for setting related parameters of Ventilation.

4. PARAMETER SETTING DESCRIPTION IN THE ETS (continues)

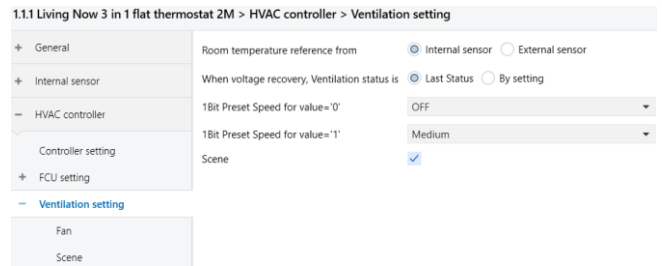

Figure 4.13 HVAC controller > Ventilation setting

Parameter "Room temperature reference from"

This parameter for setting the resource of the Ventilation function temperature reference.

Options:

Internal sensor

External sensor

When parameter "Room temperature reference from" set as "External sensor", set parameters shown as below.



Parameter "Time period for request external sensor[0..255]min"

This parameter for setting the period for read request external sensor.

Options: 0 ... 255

Parameter "When voltage recovery, Ventilation status is"

Setting ventilation status after bus recovery.

Options:

Last Status

By setting

When parameter "When bus recovery, Ventilation status is" set as "By setting", set parameters shown as below.

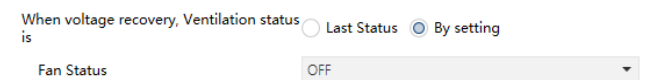

Parameter "Fan Status"

Setting fan status of ventilation after bus recovery.

Options:

OFF

Low

Medium

High

4. PARAMETER SETTING DESCRIPTION IN THE ETS (continues)

Parameter "1Bit Preset Speed for value='0'"

Parameter "1Bit Preset Speed for value='1'"

These two parameters setting preset value of fan speed, when receive telegram '0' or '1' from bus.

Options:

- OFF
- Low
- Medium
- High

Parameter "Scene"

This parameter for setting whether to enable Scene control of ventilation.

4.7.1. HVAC controller > Ventilation setting > Fan

Parameter setting interface "HVAC controller > Ventilation setting > Fan" shown as Figure 4.14, it is mainly for setting related parameters of Fan, such as "Output value for Fan speed", "Status feedback for Fan speed" and so on.

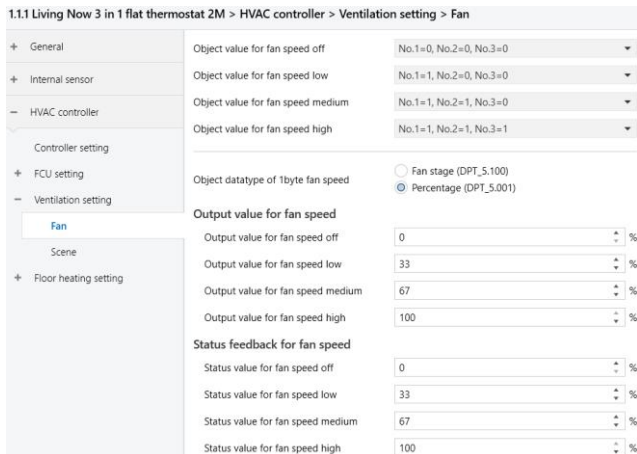

Figure 4.14 HVAC controller > Ventilation setting > Fan

Parameter "Object value for fan speed off"

Parameter "Object value for fan speed low"

Parameter "Object value for fan speed medium"

Parameter "Object value for fan speed high"

These parameters defining the switching value sent by each fan speed, the value is sent by three 1bit objects at the same time.

Options:

- No.1=0, No.2=0, No.3=0
- No.1=1, No.2=0, No.3=0
- No.1=0, No.2=1, No.3=0
- No.1=1, No.2=1, No.3=0
- No.1=0, No.2=0, No.3=1
- No.1=1, No.2=0, No.3=1

4. PARAMETER SETTING DESCRIPTION IN THE ETS (continues)

No.1=0, No.2=1, No.3=1

No.1=1, No.2=1, No.3=1

Parameter "Object datatype of 1byte fan speed"

This parameter setting for the object datatype of the setpoint:

Options:

- Fan stage (DPT_5.100)
- Percentage (DPT5.001)

Output value for fan speed

Parameter "Output value for fan speed off"

Parameter "Output value for fan speed low"

Parameter "Output value for fan speed medium"

Parameter "Output value for fan speed high"

The following parameters setting the output value of each fan speed.

Options:

0 ... 255

("Object datatype of 1byte fan speed" set as "Fan stage (DPT_5.100)")

0% ... 100%

("Object datatype of 1byte fan speed" set as "Percentage (DPT5.001)")

Status feedback for fan speed

Parameter "Status value for fan speed off"

Parameter "Status value for fan speed low"

Parameter "Status value for fan speed medium"

Parameter "Status value for fan speed high"

The following parameters setting the status value of each fan speed.

Options:

0 ... 255

("Object datatype of 1byte fan speed" set as "Fan stage (DPT_5.100)")

0% ... 100%

("Object datatype of 1byte fan speed" set as "Percentage (DPT5.001)")

4. PARAMETER SETTING DESCRIPTION IN THE ETS (continues)

■ 4.7.2. HVAC controller > Ventilation setting > Scene

Parameter setting interface “HVAC controller > Ventilation setting > Scene” of Ventilation shown as Figure 4.15, it is mainly for setting related parameters of Ventilation scene.

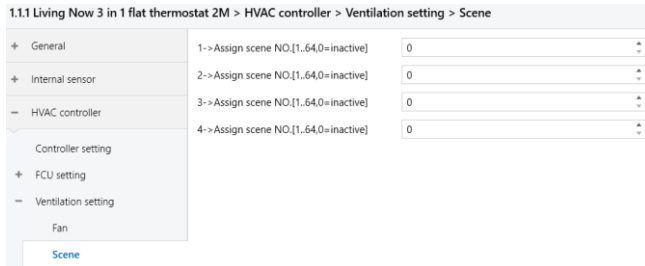

Figure 4.15 HVAC controller > Ventilation setting > Scene

Parameter “1->Assign scene NO. [1..64,0=inactive]”

Parameter “2->Assign scene NO. [1..64,0=inactive]”

Parameter “3->Assign scene NO. [1..64,0=inactive]”

Parameter “4->Assign scene NO. [1..64,0=inactive]”

These parameters for setting the scene number.

Options: 1 ... 64, 0=inactive

When these parameters not zero, set the parameters shown as below.



Parameter “Fan Status”

This parameter for setting fan speed of Air-conditioner when scene recall.

Options:

- OFF
- Low
- Medium
- High

4. PARAMETER SETTING DESCRIPTION IN THE ETS (continues)

■ 4.8. HVAC controller > Floor heating setting

Parameter setting interface “HVAC controller > Floor heating setting” shown as Figure 4.16, it is mainly for setting related parameters of Floor heating.

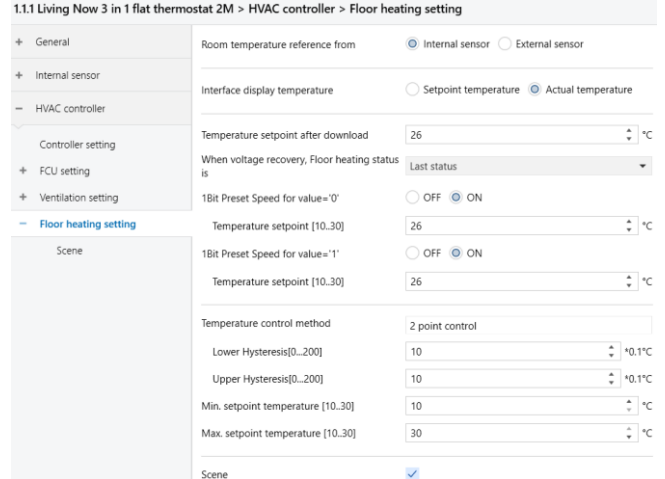

Figure 4.16 HVAC controller > Floor heating setting

Parameter “Room temperature reference from”

Setting room temperature of FCU from external or internal sensor detection.

Options:

- Internal sensor
- External sensor

When parameter “Room temperature reference from” set as “External sensor”, set parameter shown as below.

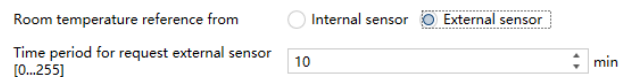

Parameter “Time period for request external sensor [0..255]min”

This parameter for setting the period for read request external sensor.

Options: 0 ... 255

Parameter “Interface display temperature”

Set the temperature under which function is displayed in the default state.

Options:

- Setpoint temperature
- Actual temperature

Setpoint temperature: Displays the temperature value set by the user by default.

Actual temperature: Display the actual temperature value detected by the device by default.

4. PARAMETER SETTING DESCRIPTION IN THE ETS (continues)

Parameter "Temperature setpoint after download"

Display the default floor heating setpoint after downloading.

Options: 10°C ... 30°C

Parameter "When voltage recovery, Floor heating status is"

This parameter sets what the state of floor heating is when the bus voltage is covered.

Options:

OFF

ON

Last Status

Parameter "When voltage recovery, Floor heating status is" set as "ON"

set parameters shown as below.



Parameter "Temperature setpoint [10..30]°C"

Setting temperature setpoint when voltage recovery.

Options: 10°C ... 30°C

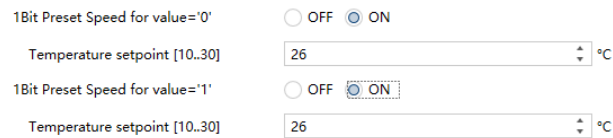

Parameter "1Bit Preset Speed for value='0'"

Options:

OFF

ON

Parameter "Temperature setpoint [10..30]°C"

Options: 10 ... 30

Parameter "1Bit Preset Speed for value='1'"

Options:

OFF

ON

Parameter "Temperature setpoint [10..30]°C"

Options: 10 ... 30

These four parameters setting preset value of temperature setpoint, when receive telegram '0' or '1' from bus.

Options: 10 ... 30

Parameter "Temperature control method"

Parameter "Lower Hysteresis[0...200]*0.1°C"

Parameter "Upper Hysteresis[0...200]*0.1°C"

These two parameters for setting the lower/upper hysteresis temperature in Floor heating.

4. PARAMETER SETTING DESCRIPTION IN THE ETS (continues)

When the actual temperature(T) > the setting temperature + the upper hysteresis temperature, then will stop heating.

When the actual temperature(T) < the setting temperature – the lower hysteresis temperature, then will start heating.

Options: 0...200

Parameter "Min. setpoint temperature [10...30]°C"

Parameter "Max. setpoint temperature [10...30]°C"

These two parameters setting the adjustment range for limiting the setting temperature. The setting minimum value should be less than the maximum value.

Options: 10 ... 30

If the setting temperature beyond the range, then output the limited value.

Parameter "Scene"

This parameter for setting whether to enable Scene control of Floor heating.

■ 4.8.1. HVAC controller > Floor heating setting> Scene

Parameter setting interface "HVAC controller > Floor heating setting > Scene" of Floor heating shown as Figure 4.17, it is mainly for setting related parameters of Floor heating scene.

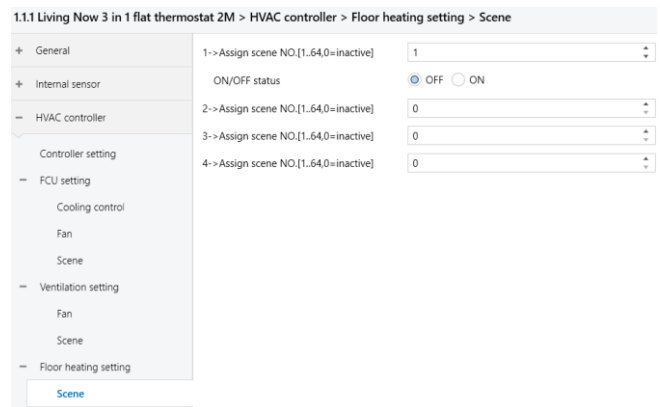

Figure 4.17 HVAC controller > Floor heating setting> Scene

Parameter "1->Assign scene NO. [1..64,0=inactive]"

Parameter "2->Assign scene NO. [1..64,0=inactive]"

Parameter "3->Assign scene NO. [1..64,0=inactive]"

Parameter "4->Assign scene NO. [1..64,0=inactive]"

These parameters for setting the scene number.

Options: 1...64, 0=inactive

When these parameters not zero, set the parameters shown as below.



Parameter "ON/OFF status"

This parameter for setting ON/OFF status of Floor heating

4. PARAMETER SETTING DESCRIPTION IN THE ETS (continues)

when scene recall.

Options:

OFF

ON

When these parameters set as "ON", set the parameters shown as below.

1 -> Assign scene NO.[1..64,0=inactive]

ON/OFF status OFF ON

Temperature setpoint [10..30] °C

Parameter "Temperature setpoint [10..30]°C"

This parameter for setting Temperature setpoint of Floor heating when scene recall.

Options: 10 ... 30

5. COMMUNICATION OBJECT

The communication object is the medium to communicate other device on the bus, namely only the communication object can communicate with the bus.

NOTE: "C" in "Flag" column in the below table means enable the communication function of the object; "W" means value of object can be written from the bus; "R" means the value of the object can be read by the other devices; "T" means the object has the transmission function; "U" means the value of the object can be updated.

	Number ▲	Name	Object Function	De	Lir	Ot	Length	C	R	W	T	U	Data Type	Priority
	37	General	Screen locking				1 bit	C	-	W	-	-	enable	Low
	38	Internal sensor	Temperature value				2 bytes	C	R	-	T	-	temperature (°C)	Low
	39	AC	External temperature, In				2 bytes	C	-	W	T	U	temperature (°C)	Low
	40	AC	ON/OFF, Out				1 bit	C	-	-	T	-	switch	Low
	41	AC	ON/OFF Status, In				1 bit	C	-	W	-	U	switch	Low
	42	AC	Preset 1Bit, In				1 bit	C	-	W	-	-	scene	Low
	43	AC	Mode, Out				1 byte	C	-	-	T	-	HVAC control mode	Low
	44	AC	Mode status, In				1 byte	C	-	W	-	U	HVAC control mode	Low
	45	AC	Fan speed, Out				1 byte	C	-	-	T	-	percentage (0..100%)	Low
	46	AC	Fan speed status, In				1 byte	C	-	W	-	U	percentage (0..100%)	Low
	47	AC	Setpoint temperature, Out				2 bytes	C	-	-	T	-	temperature (°C)	Low
	48	AC	Setpoint temperature, In				2 bytes	C	-	W	-	U	temperature (°C)	Low
	53	AC	Scene, In				1 byte	C	-	W	-	-	scene number	Low
	54	Ventilation	External temperature, In				2 bytes	C	-	W	T	U	temperature (°C)	Low
	55	Ventilation	ON/OFF, Out				1 bit	C	-	-	T	-	switch	Low
	56	Ventilation	ON/OFF Status, In				1 bit	C	-	W	-	-	switch	Low
	57	Ventilation	Fan speed No.1 1Bit, Out				1 bit	C	-	-	T	-	switch	Low
	58	Ventilation	Fan speed No.2 1Bit, Out				1 bit	C	-	-	T	-	switch	Low
	59	Ventilation	Fan speed No.3 1Bit, Out				1 bit	C	-	-	T	-	switch	Low
	60	Ventilation	Fan speed, Out				1 byte	C	-	-	T	-	percentage (0..100%)	Low
	61	Ventilation	Fan speed status, In				1 byte	C	-	W	-	-	percentage (0..100%)	Low
	62	Ventilation	Preset 1Bit, In				1 bit	C	-	W	-	-	scene	Low
	68	Ventilation	Scene, In				1 byte	C	-	W	-	-	scene number	Low
	69	Floor Heating	External temperature, In				2 bytes	C	-	W	T	U	temperature (°C)	Low
	70	Floor Heating	ON/OFF, Out				1 bit	C	R	-	T	-	switch	Low
	71	Floor Heating	ON/OFF status, In				1 bit	C	-	W	-	U	switch	Low
	72	Floor Heating	Preset 1Bit, In				1 bit	C	-	W	-	-	scene	Low
	73	Floor Heating	Setpoint temperature, Out				2 bytes	C	R	-	T	-	temperature (°C)	Low
	74	Floor Heating	Setpoint temperature, In				2 bytes	C	-	W	-	U	temperature (°C)	Low
	75	Floor Heating	Scene, In				1 byte	C	-	W	-	-	scene number	Low
	76	Floor Heating	Heating ON/OFF, Out				1 bit	C	R	-	T	-	switch	Low
	78	FCU	ON/OFF status, In				1 bit	C	-	W	-	U	switch	Low
	79	FCU	External temperature, In				2 bytes	C	-	W	T	U	temperature (°C)	Low
	80	FCU	Current temperature setpoint, In				2 bytes	C	-	W	-	U	temperature (°C)	Low
	81	FCU	Heating/Cooling mode, In				1 bit	C	-	W	-	U	cooling/heating	Low
	83	FCU	Fan speed, In				1 byte	C	-	W	T	U	percentage (0..100%)	Low
	84	FCU	Fan automatic operation, In				1 bit	C	-	W	T	U	enable	Low
	89	FCU	Scene, In				1 byte	C	-	W	-	-	scene control	Low
	90	FCU	ON/OFF, Out				1 bit	C	R	-	T	-	switch	Low
	93	FCU	Current setpoint adjustment, Out				2 bytes	C	R	-	T	-	temperature (°C)	Low
	94	FCU	Heating/Cooling mode, Out				1 bit	C	R	-	T	-	cooling/heating	Low
	96	FCU	Heating control value, Out				1 bit	C	R	-	T	-	switch	Low
	97	FCU	Cooling control value, Out				1 bit	C	R	-	T	-	switch	Low
	98	FCU	Fan speed, Out				1 byte	C	R	-	T	-	percentage (0..100%)	Low
	99	FCU	Fan Automatic operation, Out				1 bit	C	R	-	T	-	enable	Low

5. COMMUNICATION OBJECT (continues)

■ 5.1 "General" Communication Object

Number ▲	Name	Object Function	De	Lin	Ot	Length	C	R	W	T	U	Data Type	Priority
 37	General	Screen locking				1 bit	C	-	W	-	-	enable	Low

NO.	Name	Object Function	Length	Flag	DPT
37	General	Screen locking	1bit	C, W	enable

This communication object is used to receive telegram value from bus to lock the screen of device.

Telegram value:

Disable

Enable











■ 5.2. " Internal sensor" Communication Object

Number ▲	Name	Object Function	De	Lin	Ot	Length	C	R	W	T	U	Data Type	Priority
 38	Internal sensor	Temperature value				2 bytes	C	R	-	T	-	temperature (°C)	Low

NO.	Name	Object Function	Length	Flag	DPT
38	Temperature value	Internal sensor	2 bytes	C, R, T	temperature (°C)

The communication object is used to send telegram value of temperature detected by the built-in temperature sensor of the device to the bus.

■ 5.3. "AC" Communication Object

Number ▲	Name	Object Function	De	Lin	Ot	Length	C	R	W	T	U	Data Type	Priority
 39	AC	External temperature, In				2 bytes	C	-	W	T	U	temperature (°C)	Low
 40	AC	ON/OFF, Out				1 bit	C	-	-	T	-	switch	Low
 41	AC	ON/OFF Status, In				1 bit	C	-	W	-	U	switch	Low
 42	AC	Preset 1Bit, In				1 bit	C	-	W	-	-	scene	Low
 43	AC	Mode, Out				1 byte	C	-	-	T	-	HVAC control mode	Low
 44	AC	Mode status, In				1 byte	C	-	W	-	U	HVAC control mode	Low
 45	AC	Fan speed, Out				1 byte	C	-	-	T	-	percentage (0..100%)	Low
 46	AC	Fan speed status, In				1 byte	C	-	W	-	U	percentage (0..100%)	Low
 47	AC	Setpoint temperature, Out				2 bytes	C	-	-	T	-	temperature (°C)	Low
 48	AC	Setpoint temperature, In				2 bytes	C	-	W	-	U	temperature (°C)	Low
 53	AC	Scene, In				1 byte	C	-	W	-	-	scene number	Low

NO.	Name	Object Function	Length	Flag	DPT
39	AC	External temperature, In	2 bytes	C, W, T, U	temperature (°C)

This communication object is used to receive the temperature value from bus, and the temperature value on the device will be updated.

NO.	Name	Object Function	Length	Flag	DPT
40	AC	ON/OFF, Out	1 byte	C, T	counter pulses (0.255)

This communication object is used to send control telegram value of AC ON/OFF status.

Telegram value:

ON

OFF

NO.	Name	Object Function	Length	Flag	DPT
41	AC	ON/OFF Status, In	1 byte	C, W, U	counter pulses (0.255)

This communication object is used to receive the status feedback value of AC ON/OFF status.

Telegram value:

ON

OFF

5. COMMUNICATION OBJECT (continues)

NO.	Name	Object Function	Length	Flag	DPT
42	AC	Preset 1Bit, In	1 bit	C, W	scene
<p>This communication object is used to receive returning to the preset state command of AC from bus.</p> <p>Telegram value:</p> <p>0</p> <p>1</p>					
43	AC	Mode, Out	1 byte	C, T	HVAC control mode
<p>This communication object is used to send the control telegram of AC each mode to bus.</p> <p>Telegram value:</p> <p>Auto</p> <p>Cool</p> <p>Heat</p> <p>Dry</p> <p>Fan</p>					
44	AC	Mode status, In	1 byte	C, W, U	HVAC control mode
<p>This communication object is used to send the control telegram of AC each mode to bus.</p> <p>Telegram value:</p> <p>Auto</p> <p>Cool</p> <p>Heat</p> <p>Dry</p> <p>Fan</p>					
45	AC	Fan speed, Out	1 byte	C, T	percentage(0..100%)
<p>This communication object is used to send the control telegram of AC fan speed to bus.</p> <p>Telegram value:</p> <p>0% ... 100%</p> <p>or 0...255</p>					
46	AC	Fan speed status, In	1 byte	C, W, U	percentage(0..100%)
<p>This communication object is used to receive status feedback of AC fan speed.</p> <p>Telegram value:</p> <p>0% ... 100%</p> <p>or 0...255</p>					
47	AC	Setpoint temperature, Out	2 bytes	C, T	temperature (°C)
<p>This communication object is used to send the control telegram of AC setpoint temperature to bus.</p> <p>Telegram value: 16°C...30°C</p>					
48	AC	Setpoint temperature, In	2 bytes	C, W, U	temperature (°C)
<p>This communication object is used to receive the temperature setting value from bus, and the temperature setting value on the device will be updated.</p> <p>Telegram value: 16°C...30°C</p>					
53	AC	Scene, In	1 byte	C, W	scene number
<p>This communication object is used to recall the scene control of AC. The parameter is set to the scene No.1~64, and the actual corresponding telegram value is 0~63.</p>					

5. COMMUNICATION OBJECT (continues)

■ 5.4. " Ventilation" Communication Object

Number ▲	Name	Object Function	De	Lin	Ot	Length	C	R	W	T	U	Data Type	Priority
54	Ventilation	External temperature, In				2 bytes	C	-	W	T	U	temperature (°C)	Low
55	Ventilation	ON/OFF, Out				1 bit	C	-	-	T	-	switch	Low
56	Ventilation	ON/OFF Status, In				1 bit	C	-	W	-	-	switch	Low
57	Ventilation	Fan speed No.1 1Bit, Out				1 bit	C	-	-	T	-	switch	Low
58	Ventilation	Fan speed No.2 1Bit, Out				1 bit	C	-	-	T	-	switch	Low
59	Ventilation	Fan speed No.3 1Bit, Out				1 bit	C	-	-	T	-	switch	Low
60	Ventilation	Fan speed, Out				1 byte	C	-	-	T	-	percentage (0..100%)	Low
61	Ventilation	Fan speed status, In				1 byte	C	-	W	-	-	percentage (0..100%)	Low
62	Ventilation	Preset 1Bit, In				1 bit	C	-	W	-	-	scene	Low
68	Ventilation	Scene, In				1 byte	C	-	W	-	-	scene number	Low

NO.	Name	Object Function	Length	Flag	DPT
54	Ventilation	External temperature, In	2 bytes	C, W, T, U	temperature (°C)
This communication object is used to receive the temperature value from bus, and the temperature value on the device will be updated.					
55	Ventilation	ON/OFF, Out	1 bit	C, T	switch
This communication object is used to send control command of Ventilation ON/OFF status to bus. Telegram value: ON OFF					
56	Ventilation	ON/OFF Status, In	1 bit	C, W	switch
This communication object is used to receive the status feedback value of Ventilation ON/OFF status. Telegram value: ON OFF					
57	Ventilation	Fan speed No.1 1Bit, Out	1 bit	C, T	switch
58	Ventilation	Fan speed No.2 1Bit, Out	1 bit	C, T	switch
59	Ventilation	Fan speed No.3 1Bit, Out	1 bit	C, T	switch
These three communication objects are used to send telegram value to bus at same time. These values are used to control fan speed together that set by the parameters shown as below. "Object value for fan speed off." "Object value for fan speed low" "Object value for fan speed medium" "Object value for fan speed high" Telegram value: ON OFF					
60	Ventilation	Fan speed, Out	1 byte	C, T	percentage (0..100%)
This communication object is used to send the control telegram of Ventilation fan speed to bus. Telegram value: 0% ... 100% or 0...255					

5. COMMUNICATION OBJECT (continues)

61	Ventilation	Fan speed status, In	1 byte	C, W	percentage (0..100%)
This communication object is used to receive status feedback of Ventilation fan speed. Telegram value: 0% ... 100% or 0...255					
62	Ventilation	Preset 1Bit, In	1 bit	C, W	scene
This communication object is used to receive returning to the preset state command from bus. Telegram value: 0 1					
68	Ventilation	Scene. In	1 byte	C, W	scene number
This communication object is used to recall the scene control of ventilation. The parameter is set to the scene No.1~64, and the actual corresponding telegram value is 0~63.					

■ 5.5. " Floor Heating" Communication Object

	Number ▲	Name	Object Function	De	Lin	Of	Length	C	R	W	T	U	Data Type	Priority
	69	Floor Heating	External temperature, In				2 bytes	C	-	W	T	U	temperature (°C)	Low
	70	Floor Heating	ON/OFF, Out				1 bit	C	R	-	T	-	switch	Low
	71	Floor Heating	ON/OFF status, In				1 bit	C	-	W	-	U	switch	Low
	72	Floor Heating	Preset 1Bit, In				1 bit	C	-	W	-	-	scene	Low
	73	Floor Heating	Setpoint temperature, Out				2 bytes	C	R	-	T	-	temperature (°C)	Low
	74	Floor Heating	Setpoint temperature, In				2 bytes	C	-	W	-	U	temperature (°C)	Low
	75	Floor Heating	Scene, In				1 byte	C	-	W	-	-	scene number	Low
	76	Floor Heating	Heating ON/OFF, Out				1 bit	C	R	-	T	-	switch	Low

NO.	Name	Object Function	Length	Flag	DPT
69	Floor Heating	External temperature, In	2 bytes	C, W, T, U	temperature (°C)
This communication object is used to receive the temperature value from bus, and the temperature value on the device will be updated.					
70	Floor Heating	ON/OFF, Out	1bit	C, R, T	switch
This communication object is used to send control command of Floor Heating ON/OFF status to bus. Telegram value: ON OFF					
71	Floor Heating	ON/OFF status, In	1bit	C, W, U	switch
This communication object is used to receive the status feedback value of Floor Heating ON/OFF status. Telegram value: ON OFF					
72	Floor Heating	Preset 1Bit, In	1 bit	C, W	scene
This communication object is used to receive returning to the preset state command from bus. Telegram value: 0 1					

5. COMMUNICATION OBJECT (continues)

73	Floor Heating	Setpoint temperature, Out	2 bytes	C, R, T	temperature (°C)
This communication object is used to send the control telegram of Floor Heating setpoint temperature to bus. Telegram value: 16°C...30°C					
74	Floor Heating	Setpoint temperature, In	2 bytes	C, W, U	temperature (°C)
This communication object is used to receive the temperature setting value from bus, and the temperature setting value on the device will be updated. Telegram value: 16°C...30°C					
75	Floor Heating	Scene, In	1 byte	C, W	scene number
This communication object is used to recall the scene control of floor Heating. The parameter is set to the scene No.1~64, and the actual corresponding telegram value is 0~63.					
76	Floor Heating	Heating ON/OFF, Out	1 bit	C, R, T	switch
This communication object is used to send the control telegram of Floor Heating ON or OFF to bus. Telegram value: ON OFF					

■ 5.6. "FCU" Communication Object

Number ▲	Name	Object Function	De	Lin	Ot	Length	C	R	W	T	U	Data Type	Priority
78	FCU	ON/OFF status, In				1 bit	C	-	W	-	U	switch	Low
79	FCU	External temperature, In				2 bytes	C	-	W	T	U	temperature (°C)	Low
80	FCU	Current temperature setpoint, In				2 bytes	C	-	W	-	U	temperature (°C)	Low
81	FCU	Heating/Cooling mode, In				1 bit	C	-	W	-	U	cooling/heating	Low
83	FCU	Fan speed, In				1 byte	C	-	W	T	U	percentage (0..100%)	Low
84	FCU	Fan automatic operation, In				1 bit	C	-	W	T	U	enable	Low
89	FCU	Scene, In				1 byte	C	-	W	-	-	scene control	Low
90	FCU	ON/OFF, Out				1 bit	C	R	-	T	-	switch	Low
93	FCU	Current setpoint adjustment, Out				2 bytes	C	R	-	T	-	temperature (°C)	Low
94	FCU	Heating/Cooling mode, Out				1 bit	C	R	-	T	-	cooling/heating	Low
96	FCU	Heating control value, Out				1 bit	C	R	-	T	-	switch	Low
97	FCU	Cooling control value, Out				1 bit	C	R	-	T	-	switch	Low
98	FCU	Fan speed, Out				1 byte	C	R	-	T	-	percentage (0..100%)	Low
99	FCU	Fan Automatic operation, Out				1 bit	C	R	-	T	-	enable	Low

NO.	Name	Object Function	Length	Flag	DPT
78	FCU	ON/OFF status, In	1bit	C, W, U	switch
This communication object is used to receive the feedback telegram value of FCU ON/OFF status. Telegram value: ON OFF					
79	FCU	External temperature, In	2 bytes	C, W, T, U	temperature (°C)
This communication object is used to receive the temperature value from bus, and the temperature value on the device will be updated. Telegram value: 16°C...30°C					
80	FCU	Current temperature setpoint, In	2 bytes	C, W, U	temperature (°C)
This communication object is used to receive telegram value of FCU setpoint temperature from bus, and the setpoint temperature on the device displayed will be updated. Telegram value: 10°C ... 35°C					

5. COMMUNICATION OBJECT (continues)

81	FCU	Heating/Cooling mode, In	1 bit	C, W, U	cooling/heating
<p>This communication object is used to receive status feedback of FCU heating or cooling.</p> <p>Telegram value:</p> <p style="padding-left: 40px;">Heating</p> <p style="padding-left: 40px;">Cooling</p>					
83	FCU	Fan speed, In	1 byte	C, W, T, U	percentage(0..100%)
<p>This communication object is used to receive status feedback of FCU fan speed.</p> <p>Telegram value:</p> <p style="padding-left: 40px;">0% ... 100%</p> <p style="padding-left: 40px;">or 0...255</p>					
84	FCU	Fan automatic operation, In	1 bit	C, W, T, U	enable
<p>This communication object is used to receive status feedback of FCU fan automatic .</p> <p>Telegram value:</p> <p style="padding-left: 40px;">0</p> <p style="padding-left: 40px;">1</p>					
89	FCU	Scene, In	1 byte	C, W	scene control
<p>This communication object is used to recall the scene control of FCU. The parameter is set to the scene No.1~64, and the actual corresponding telegram value is 0~63.</p>					
90	FCU	ON/OFF, Out	1 bit	C, R, T	switch
<p>This communication object is used to receive the feedback telegram value of FCU ON/OFF status.</p> <p>Telegram value:</p> <p style="padding-left: 40px;">ON</p> <p style="padding-left: 40px;">OFF</p>					
93	FCU	Current setpoint adjustment, Out	2 bytes	C, R, T	temperature (°C)
<p>This communication object is used to send the telegram value of FCU current base setpoint temperature to bus.</p> <p>Telegram value: 10°C...35°C</p>					
94	FCU	Heating/Cooling mode, Out	1bit	C, R, T	cooling/heating
<p>This communication object is used to send control telegram value of FCU Heating or Cooling mode to bus.</p> <p>Telegram value:</p> <p style="padding-left: 40px;">Heating</p> <p style="padding-left: 40px;">Cooling</p>					
96	FCU	Heating control value, Out	1bit	C, R, T	switch
<p>This communication objects is used to send control telegram value of FCU Heating to bus.</p> <p>Telegram value:</p> <p style="padding-left: 40px;">ON</p> <p style="padding-left: 40px;">OFF</p>					
97	FCU	Cooling control value, Out	1 bit	C, R, T	switch
<p>This communication object is used to send control telegram value of FCU Cooling to bus.</p> <p>Telegram value:</p> <p style="padding-left: 40px;">ON</p> <p style="padding-left: 40px;">OFF</p>					

5. COMMUNICATION OBJECT (continues)

98	FCU	Fan speed, Out	1 byte	C, R, T	percentage(0..100%)
<p>This communication object is used to send the control telegram of FCU fan speed to bus.</p> <p>Telegram value:</p> <p style="padding-left: 40px;">0% ... 100%</p> <p style="padding-left: 40px;">or 0...255</p>					
99	FCU	Fan Automatic operation, Out	1bit	C, R, T	enable
<p>This communication object is used to send the control telegram of FCU fan automatic operation to bus.</p> <p>Telegram value:</p> <p style="padding-left: 40px;">0</p> <p style="padding-left: 40px;">1</p>					