

CONTENTS PAGE

- **1. Use** **3**
- **2. Technical characteristics** **3**
 - 2.1 Electrical characteristics 3
 - 2.2 Connections characteristics 3
 - 2.3 Consumption 3
 - 2.4 Type of load: 3
 - 2.5 Mechanical characteristics 3
 - 2.6 Climate characteristics 3
- **3. Dimensions** **3**
- **4. Connection** **4**
- **5. Operation** **6**
 - 5.1 Description of the device 6
 - 5.2 Commissioning 6
- **6. Standards** **6**
- **7. Communication objects** **7**
 - 7.1 List of objects 7
 - 7.2 "General" parameter 8
 - 7.3 "Weather alarms" parameter 8
 - 7.4 List of scene 9
 - 7.5 "Enable Input a...s" parameter 9
 - 7.5.1 "a - Switch Sensor" parameter 10
 - 7.5.2 "a - Switch Dim Sensor" parameter 11
 - 7.5.2 "a - Switch Dim Sensor" parameter (continued) 11
 - 7.5.3 "a - Blind Sensor" parameter 11
 - 7.5.4 "a - Value/Forced Operation" parameter 12
 - 7.6 "Enable Output A...J" parameter 13
 - 7.7 "Switch" parameter 14
 - 7.7.1 "A1 - General" parameter 14
 - 7.7.2 "A1 - Function" parameter 14
 - 7.7.2.1 "A1 - Staircase Function" parameter 14
 - 7.7.2.2 "A1 - External logic" parameter 15
 - 7.7.2.3 "A1 - Sweep" parameter 15
 - 7.7.2.4 "A1 - Scene" parameter 16
 - 7.8 "Blind" parameter 16
 - 7.8.1 "A/B - General" parameter 16
 - 7.8.2 "A/B - Drive Blind" parameter 17
 - 7.8.3 "A/B - Drive Slat" parameter 18
 - 7.8.4 "A/B - Functions" parameter 18
 - 7.8.4.1 "A/B - Position/Presets" parameter 18
 - 7.8.4.2 "A/B - Position/Presets" parameter 19
 - 7.8.4.3 "A/B - Forced position" parameter 20
 - 7.8.4.4 "A/B - Feedbacks" parameter 20
 - 7.8.4.5 "A/B - Scene" parameter 20
 - 7.9 "Valve Control" parameter 21
 - 7.9.1 "A/B - Control Input" parameter 21
 - 7.9.2 "A - Valve General" parameter 21
 - 7.9.3 "A - Function" parameter 22
 - 7.9.4 "A - Limit" parameter 23

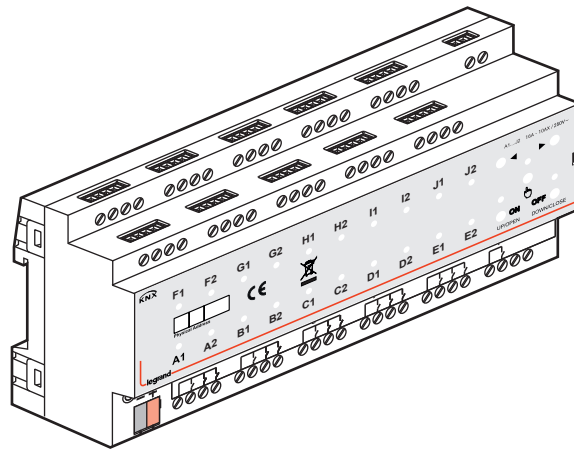

CONTENTS..... PAGE

7.10 "Fan Coil" parameter23

7.10.1 "Fan" parameter23

7.10.2 "A/B1 - Status Message" parameter.....24

7.10.3 "A/B1 - Automatic Operation" parameter25

7.10.4 "A/B1 - Direct Mode" parameter25

7.11 Function Chart26

7.12 Object Description26

7.12.1 General Object Description26

7.13 Input Object Description27

7.14 Switch Object Description27

7.15 Blind Object Description28

7.16 Valve Object Description29

7.17 Fan Object Description29

1. USE

RCU Series are designed as an all in one product for different room layouts such as apartments, hotel rooms, hospitals and residences.

Room Control Unit covers all requirements of the electrical installation of room applications and offers following functions in one product.

- Switching lighting
- Switching loads
- Controlling AC/DC blinds
- Controlling fan coils (2 & 3-point valve)
- Dry contact inputs

RCU has up to 20 x 16A relay outputs. These outputs are grouped as 5/4/3/2 independent output channels for XX = 20/16/12/8 respectively. Each channel can be configured to have different modes of operation as follows:

- Switching output x4
- AC Blind x2
- DC Blind x1
- 2 Point valve x2
- 3 point valve x2

Suitable for switching resistive, capacitive and inductive loads as well as fluorescent lamp loads according to EN 60 669. A single switch output provides following functions:

- Staircase
- External logic
- Internal logic
- Priority
- Threshold
- Operating hour
- Sweep

RCU has up to 18 independent input channels. A single input channel provides following functions:

- Switch / push button input
- Dimmer control
- Control of shutter/blinds
- Value sending
- Scene control
- Counter for count pulse

Manual control is possible for each channel through the built-in button panel.

220V auxiliary power is NOT required.

2. TECHNICAL CHARACTERISTICS

2.1 Electrical characteristics

- Voltage: 21V... 30V~, SELV
- Current consumption: ≤ 10 mA

2.2 Connections characteristics

- Wiring (screw terminals) : 2 x 1,5 mm² / 1 x 2,5 mm²
- Max tightening torque: 0.5 Nm

2.3 Consumption

- Output: Number XX output
 - Switching voltage: 250 V~
 - Frequency: 50/60 Hz
 - Switching current 250 V~: 16A / AC 1 - 16A (200μF)
 - Capacitive loads maximum switching power: 4000 VA
 - Mechanical life: > 1 x 10⁶
- Input: Number YY binary inputs
 - Scanning voltage 5 V
 - Current 1 mA
 - Cable length < 300 m

2.4 Type of load:

240 V~	400 VA 1,6 A	2400 VA 10 A
		1800 VA 8 A

240 V~	2400 VA 10 A	4000 VA 17 A
		1000 VA 5 A

2.5 Mechanical characteristics

- IP 20
- Safety class II
- Number of modules: 6-10
- Weight: 65 g

2.6 Climate characteristics

- Operating temperature: -5°C to +45°C
- Storage temperature: -25°C to +55°C
- max. air humidity: 85 % no moisture condensation

3. DIMENSIONS

0 026 72/73/74

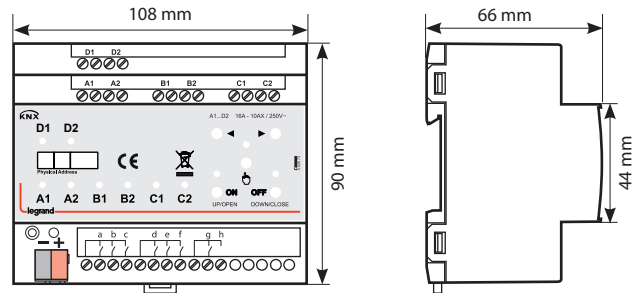

0 026 76/78/79

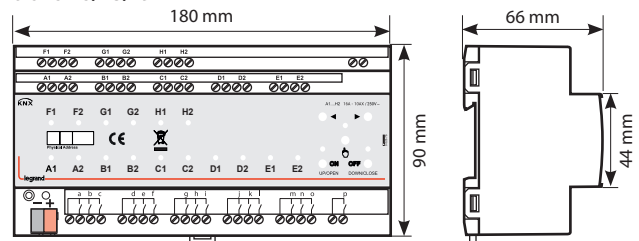

2. TECHNICAL CHARACTERISTICS (continued)

4. CONNECTION

0 026 72/73

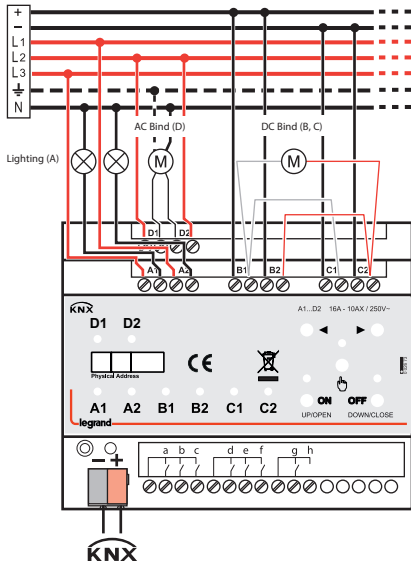
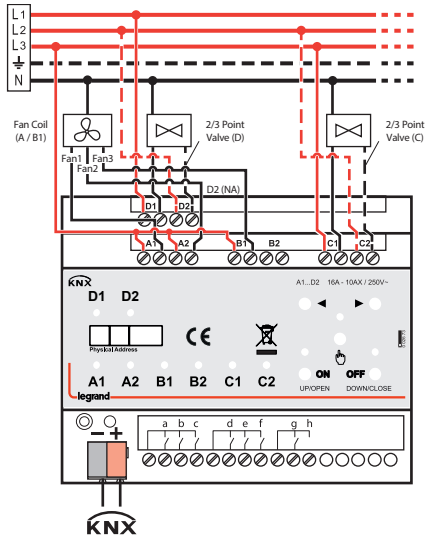

4. CONNECTION (continued)

0 026 74

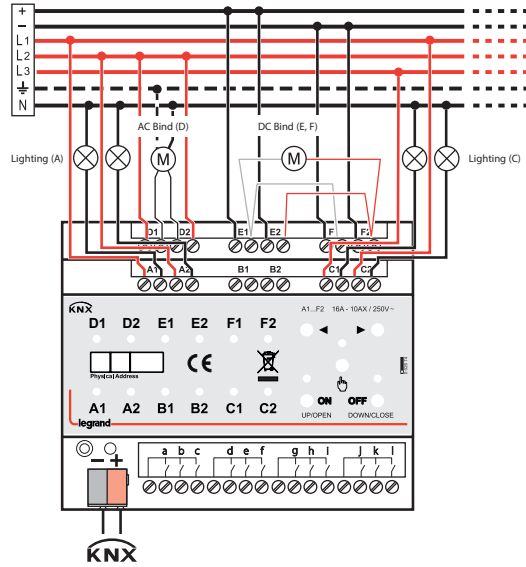
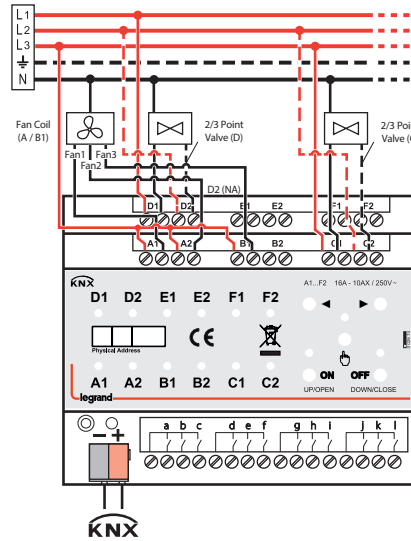

4. CONNECTION (continued)

0 026 76

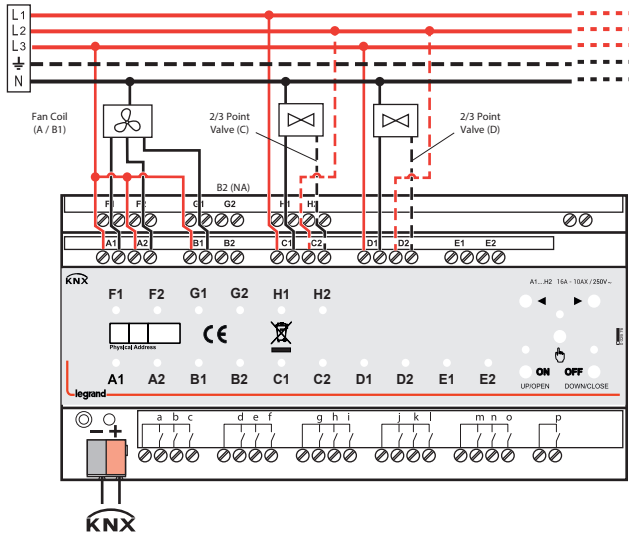

4. CONNECTION (continued)

0 026 78/79

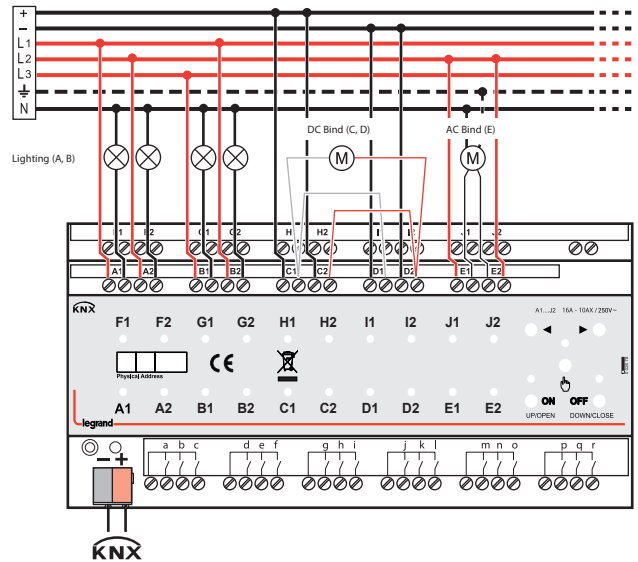
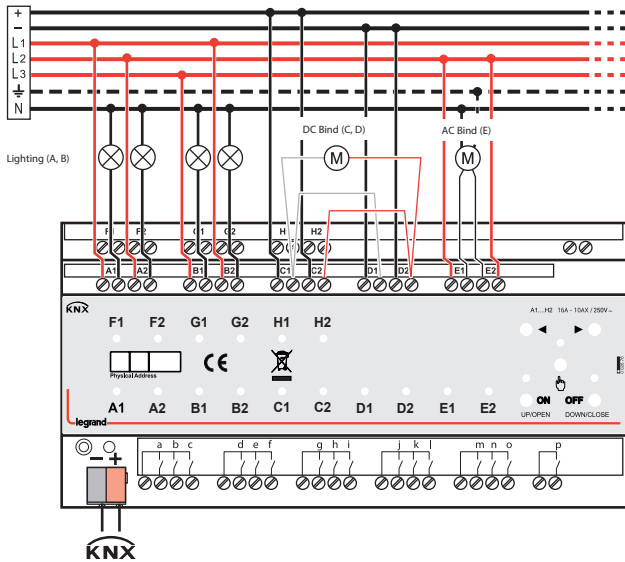
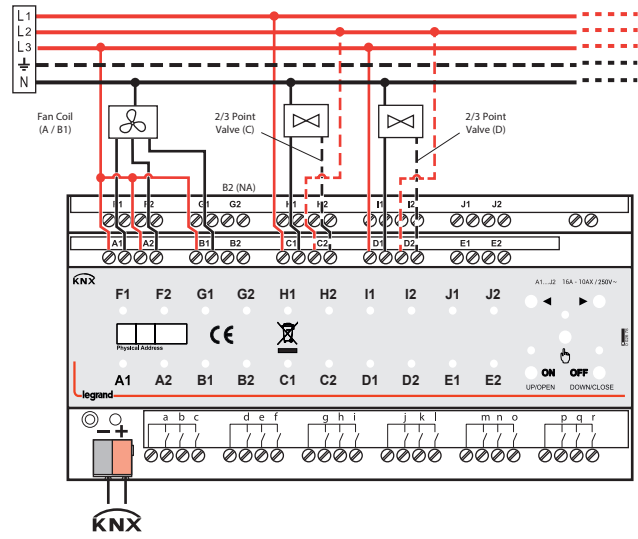

5. OPERATION

5.1 Description of the device

0 026 74

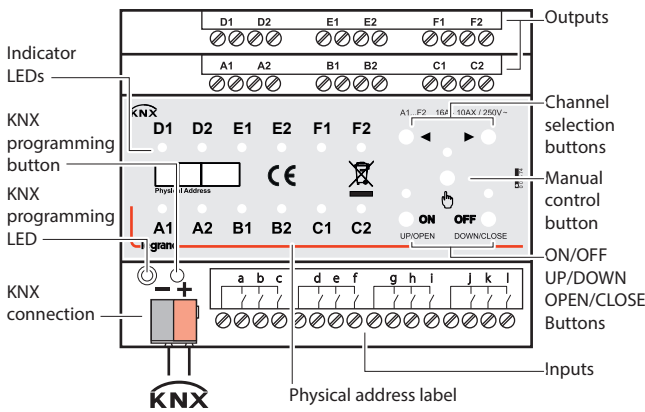

Outputs contain 5 independent outputs (AB, CD, EF, GH, IJ)

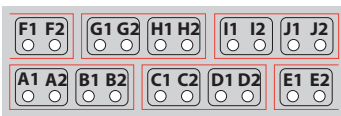

5.2 Commissioning

Physical addressing and programming can be done ETS4 or higher...

Important:

A detailed information about parameter configuration can be found in Product Manual of device.

Installation and commissioning of device may only be implemented by trained electricians. The relevant standards, directives, regulations and instructions must be observed when planning and implementing the electrical installation.

- When connecting the device make sure that the device can be isolated!
- Protect the device against moisture, dirt and damage during transport, storage and operation!
- Do not operate the device out of the specified technical data which is stated.
- The device may only be operated in closed enclosures such as distribution boards.

6. STANDARDS

- Type of protection: EN 60 529
- Safety class II: EN 61 140
- Installation: EN 60 715

7. COMMUNICATION OBJECTS

■ 7.1 List of objects

The device has 254 communication objects. Overview of all communication objects of the device can be seen on the following table. Object names will be changed according to channel function as follows.

Fan coil: Fan A/B1, Fan C/D1, Fan E/F1, Fan G/H1, Fan I/J1 etc.

Valve control: Valve A/B, Valve C/D, Valve E/F, Valve G/H, Valve I/J.

Shutter/Blind DC: Output A/B, Output C/D, Output E/F, Output G/H, Output I/J.

Shutter/Blind AC: Output A, Output B, Output C, Output D, Output E.

Switch: Output A1, Output A2, Output B1, Output B2, Output C1, Output C2 etc.

No	Name	Function	DTP Type	Length	Flags
0	General	In operation	1.002	1 bit	CWT
1	General	Scene 8-bit	18.001	1 byte	CW
2	Blind	Wind alarm	1.005	1 bit	CWTU
3	Blind	Rain alarm	1.005	1 bit	CWTU
4	Blind	Frost alarm	1.005	1 bit	CWTU
5	Input a	Disable	1.003	1 bit	CW
6	Input a	Switch	1.001	1 bit	CWT
		Switch – short	1.001	1 bit	CWT
		Shutter Up/Down	1.008	1 bit	CT
		Value (0,1)	1.001	1 bit	CWT
		Value (forced)	2.001	2 bit	CWT
		Value [0...255]	5.001	8 bit	CWT
		Value [0...65535]	8.001	16 bit	CWT
		Value [-32768...32767]	7.001	16 bit	CWT
7	Input a	Value [0...4294967295]	12.001	32 bit	CWT
		Switch – long	1.001	1 bit	CWT
		Dimming brighter / darker	3.007	4 bit	CT
		Shutter stop / lamella	1.007	1 bit	CT
		Value (0,1) - long	1.001	1 bit	CT
		Value (forced) - long	2.001	1 bit	CT
		Value [0...255] - long	5.001	8 bit	CT
		Value [0...65535] - long	8.001	16 bit	CT
		Value [-32768...32767]	7.001	16 bit	CT
		Value [0...4294967295]	12.001	32 bit	CT
8	Input a	Shutter upper limit position	1.002	1 bit	CW
		Value (temperature)	14.068	32 bit	CT
9	Input a	Shutter lower limit position	1.002	1 bit	CW
		Value (temperature) - long	14.068	32 bit	CT
10...94	Input b ... s	Same as "Input a"			
95	Output A1	Switch	1.001	1 bit	CW
	Output A Output A/B	Move blind/shutters up-down	1.008	1 bit	CW
	Fan A/B1	Fan speed switch	5.010	1 byte	CW
	Control input	Control value HEATING	5.001	1 byte	CW
96	Output A1	Status Switch	1.001	1 bit	CW
	Output A Output A/B	Slat adjustment/stop up-down	1.007	1 bit	CW
	Fan A/B1	Switch speed 1	1.001	1 bit	CW
	Control input	Control value COOLING	5.001	1 byte	CW
97	Output A1	Enable staircase function	1.003	1 bit	CRW
	Output A	Blind/shutters up-down limited	1.008	1 bit	CW
	Output A/B	Enable limitation	1.003	1 bit	CW
	Fan A/B1	Switch speed 2	1.001	1 bit	CW
	Control input	Toggle Heating/Cooling	1.100	1 bit	CW
98	Output A1	Staircase lighting duration	7.007	2 byte	CRW
	Output A Output A/B	Move to position height 0...255	5.001	1 byte	CW
	Fan A/B1	Switch speed 3	1.001	1 bit	CW
	Control input	Fault control value	1.005	1 bit	CRT
99	Output A1	Permanent ON	1.001	1 bit	CW
	Output A/B	Move slats 0...255	5.001	1 byte	CW
	Fan A/B1	Fan speed UP/DOWN	1.007	1 bit	CW
	Valve HEATING	Block	1.003	1 bit	CW

7. COMMUNICATION OBJECTS (continued)

■ 7.1 List of objects (continued)

No	Name	Function	DTP Type	Length	Flags
100	Output A1	External logic input	1.001	1 bit	CW
	Output A Output A/B	Move to position 1, 2	1.022	1 bit	CW
	Fan A/B1	Status fan ON/OFF	1.001	1 bit	CT
	Valve HEATING	Forced operation	1.003	1 bit	CW
101	Output A1	Forced positioning	2.001	2 bit	CW
	Output A Output A/B	Move to position 3, 4	1.022	1 bit	CW
	Fan A/B1	Status fan speed	5.010	1 byte	CRT
102	Valve HEATING	Trigger valve purge	1.017	1 bit	CW
	Output A1	Sweep	1.017	1 bit	CW
	Output A Output A/B	Set position 1, 2	1.022	1 bit	CW
103	Fan A/B1	Status fan speed 1	1.001	1 bit	CRT
	Valve HEATING	Status valve purge	1.003	1 bit	CRT
	Output A2	Switch	1.001	1 bit	CW
104	Output A Output A/B	Set position 3, 4	1.022	1 bit	CW
	Fan A/B1	Status fan speed 2	1.001	1 bit	CRT
	Valve HEATING	Status valve position	1.001	1 bit	CRT
	Valve HEATING	Status valve position	5.001	1 byte	CRT
105	Output A2	Status Switch	1.001	1 bit	CW
	Output A Output A/B	Trigger reference movement	1.008	1 bit	CW
	Fan A/B1	Status fan speed 3	1.001	1 bit	CRT
	Valve COOLING	Block	1.003	1 bit	CW
106	Output A2	Enable staircase function	1.003	1 bit	CRW
	Output A Output A/B	Block	1.003	1 bit	CWTU
	Fan A/B1	Forced operation	1.003	1 bit	CW
	Valve COOLING	Forced operation	1.003	1 bit	CW
107	Output A2	Staircase lighting duration	7.007	2 byte	CRW
	Output A	Forced operation 1 bit	1.003	1 bit	CWTU
	Output A/B	Forced operation 2 bit	2.002	2 bit	CW
	Fan A/B1	Automatic ON/OFF	1.003	1 bit	CW
	Valve COOLING	Trigger valve purge	1.017	1 bit	CW
108	Output A2	Permanent ON	1.001	1 bit	CW
	Output A Output A/B	Status height 0...255	5.001	1 byte	CRT
	Fan A/B1	Status automatic	1.003	1 bit	CW
109	Valve COOLING	Status valve purge	1.003	1 bit	CRT
	Output A2	External logic input	1.001	1 bit	CW
	Output A	Status slat 0...255	5.001	1 byte	CRT
110	Valve COOLING	Status valve position	1.001	1 bit	CRT
	Valve COOLING	Status valve position	5.001	1 byte	CRT
	Output A2	Forced positioning	2.001	2 bit	CW
111...254	Output A2	Status upper end position	1.011	1 bit	CRT
	Output A Output A/B	Status lower end position	1.011	1 bit	CRT
110	Output A2	Sweep	1.017	1 bit	CW
	Output A Output A/B	Status lower end position	1.011	1 bit	CRT
111...254	Output B1...U2 Output C/D... Output T/U	Same as "Output A1" for switch Same as "Output A/B" for blind			

7. COMMUNICATION OBJECTS (continued)

7.2 "General" parameter

Enable manual operation	disable *enable
--------------------------------	---------------------------

This parameter can be used to enable/disable manual control. If manual operation is enabled, connected load can be controlled via the corresponding channel button on the device.

- Set the parameter to **"enable"**

This selection is used to enable manual operation.

- Set the parameter to **"disable"**

This selection is used to disable manual operation.

Reset manual operation to KNX operation	*via push button automatically and via push button
--	--

This parameter determines how long manual operation remains activated.

Time for automatic reset in s[10...6000]	10... *300 ...6000
---	---------------------------

Manual operation remains activated until the adjusted time is up or deactivated by button manually.

Device alive operation active	*no yes
--------------------------------------	-------------------

This object is used to report that device is still alive and connected to KNX line. (Heartbeat) If alive telegram is not received, device may be defective or KNX cable can be disconnected. If parameter is selected **"yes"**, following parameters come up.

In operation bit	0 *1
-------------------------	----------------

Telegram value can be selected as "1" or "0".

In operation send interval	1... *300 ...65535
-----------------------------------	---------------------------

Telegram value is sent cyclically according to time interval.

Transmission delay [2...255s] after bus voltage return	*2 ...255
---	------------------

The parameter defines the behaviour of the actuator at a bus power return. The transmission delay time determines the period between bus voltage recovery and the point after which telegrams can be sent.

Telegram limit active	no *yes
------------------------------	-------------------

Telegrams which are sent by the gateway can be limited with this parameter. If "yes" is selected, following parameters come up.

Telegram limit period	50ms... *10s ...1dk
------------------------------	----------------------------

The limit period can be selected via telegram limit period parameter.

Max. number of transmitted telegram	1... *20 ...255
--	------------------------

Maximum number of telegrams can be sent freely within a period.

Note:

If the value of the object cannot be sent in the time of a period. The object is buffered for the next period time. The buffered object will be updated if the object value is updated.

7. COMMUNICATION OBJECTS (continued)

7.2 "General" parameter (continued)

Activate scene	*yes no
-----------------------	-------------------

If parameter is selected **"yes"**, "Scenes" section will be visible in parameter titles.

Weather alarm function	enable *disable
-------------------------------	---------------------------

If the parameter is selected "yes", "Weather Alarm" section will be visible in parameter titles. You can find weather alarm information under the "Weather Alarm" section.

7.3 "Weather alarms" parameter

Order of priority for weather alarms	*1.Wind 2.Rain 3.Frost 1.Wind 2.Frost 3.Rain 1.Rain 2.Wind 3.Frost 1.Rain 2.Frost 3.Wind 1.Frost 2.Wind 3.Rain 1.Frost 2.Rain 3.Wind
---	--

If an alarm is triggered, the drives move into a safe position and stay in safe position until the event is over. You can select the priority of the weather alarm. This parameter is applied for all blind/shutter channels which are enabled for weather protection function. If more than one weather alarms occur simultaneously, then only the alarm with highest priority will be activated. The other lower priority alarms are carried out after highest priority alarm is completed.

Wind alarm	*disable enable
-------------------	---------------------------

This parameter activates the wind alarm. If the parameter selected "enable", "Monitoring period for wind alarm in s [0...1000]" parameter will be visible.

Monitoring period for wind alarm in s [0...1000]	*0 ...1000
---	-------------------

The telegram of the active weather station is monitored cyclically. The actuator waits for a telegram from the weather station within the cycle time. If the telegram is not received within this monitoring period time, actuator assumes that the weather station is broken or bus line is damaged and the blind moves into the parameterized position.

0: If "0" is selected cyclically monitoring is deactivated. If the alarm telegram value is "1", weather alarm is activated.

Rain alarm	*disable enable
-------------------	---------------------------

This parameter activates the rain alarm. If the parameter selected "enable" "Monitoring period for rain alarm in s [0...1000]" parameter is visible.

7. COMMUNICATION OBJECTS (continued)

7.3 "Weather alarms" parameter (continued)

Monitoring period for rain alarm in s [0...1000]	*0...1000
--	-----------

The telegram of the active weather station is monitored cyclically. The actuator waits for a telegram from the weather station within the cycle time. If the telegram is not received within this monitoring period time, actuator assumes that the weather station is broken or bus line is damaged and the blind moves into the parameterized position.

• 0: If "0" is selected cyclically monitoring is deactivated. If the alarm telegram value is "1", weather alarm is activated.

Frost alarm	*disable enable
-------------	--------------------

This parameter activates the frost alarm. If the parameter selected "enable", "Monitoring period for frost alarm in s [0...1000]" parameter is visible.

Monitoring period for frost alarm in s [0...1000]	*0...1000
---	-----------

The telegram of the active weather station is monitored cyclically. The actuator waits for a telegram from the weather station within the cycle time. If the telegram is not received within this monitoring period time, actuator assumes that the weather station is broken or bus line is damaged and the blind moves into the parameterized position.

• 0: If "0" is selected cyclically monitoring is deactivated. If the alarm telegram value is "1", weather alarm is activated.

7.4 List of scene

The scene function of the switch actuator has an 8 bit scene object. You can define for each 64 scene with parameter window. 8 independent values can be stored for each relay or each blind. The scene can be specified that the relay OFF (open contact), or ON (close contact) its state for switch function. If you use the blind, you can configure the blind height and slat position. You can save height position for blind also slat-opening angle as scene values.

When the actuator receives a telegram that retrieves a scene address:

- The output group is configured as a blind, the drive is moved into the saved position and slats are turned.
- The output group is configured as a switch, the actuator evaluate the transmitted scene address and switches the output to the stored scene value.

A scene is activated when it receives its scene number at the scene object. The storing of the current channel values is carried out using the scene object.

For example:

Scene	recall		save	
	Hex.	Des.	Hex.	Des.
1	0x00	0	0x80	128
2	0x01	1	0x81	129
3	0x02	2	0x82	130
4	0x03	3	0x83	131
5	0x04	4	0x84	132
6	0x05	5	0x85	133
7	0x06	6	0x86	134
8	0x07	7	0x87	135
9	0x08	8	0x88	136
10	0x09	9	0x89	137
11	0x0A	10	0x8A	138
...
63	0x3E	62	0xE2	190
64	0x3F	63	0xE3	191

7. COMMUNICATION OBJECTS (continued)

7.4 List of scene f scene (continued)

Overwrite scene on download	no *yes
-----------------------------	------------

This parameter is selected the reaction of the scene set.

- Set the parameter to "no";

During storage of a scene, the scene values are stored in the device. If you want to protect your scene in the device, you are selected "no".

- Set the parameter to "yes";

The original ETS parameter values can be reload into the device during ETS download operation.

1...64 scene number (0 = no assignment)	*0...64
---	---------

This parameter is used to following parameter belongs to which scene. 0 meaning following parameters are not belong to any scene.

Blind position value in %[100]	*0...100
Slat position value in %[100]	*0...100
...	...
Value	*OFF ON

These parameters are the common of the blind and switch.

- If the "Output group A" is selected "2 x switch", scene parameters mean the switch state ON/OFF.
- If the "Output group A" is selected "1 x blind", scene parameters mean blind height and slat position.

If the blind type is selected roller shutter, slat position parameter is invalid. 0%: open blind, 100%: bottom blind also you can select between %0 – %100 values. This parameter is used for parameterizing the blind position, which is executed when the scene is recalled.

7.5 "Enable Input a...s" parameter

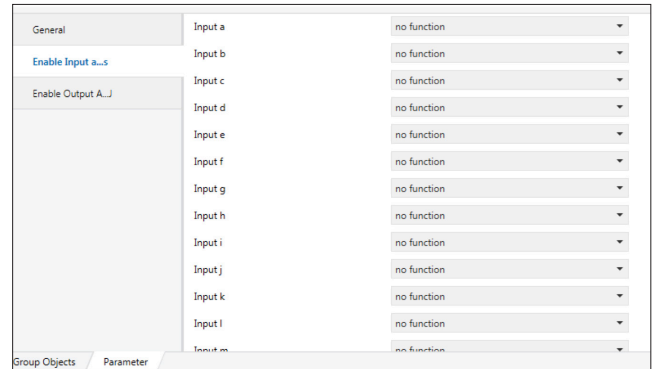

Input a...s	*no function switch sensor switch dim sensor shutter sensor value operation
-------------	---

This parameter is used to select input function.

- This parameter is selected "switch sensor"

Distinction between short/long operation and cyclical sending.

- This parameter is selected "switch dim sensor"

Start-stop dimming and stepwise dimming are possible.

- This parameter is selected "shutter sensor"

For movement/louvre adjustment of a blind or a shutter.

- This parameter is selected "value operation"

It is possible to send different values or data point types.

7. COMMUNICATION OBJECTS (continued)

7.5 "Enable Input a...s" parameter (continued)

7.5.1 "a - Switch Sensor" parameter

General	Distinction between long and short operation	<input type="radio"/> yes <input checked="" type="radio"/> no
Enable Input a...s	Connected contact type	<input type="radio"/> normally closed <input checked="" type="radio"/> normally open
a - Switch Sensor	Cyclic transmission of object	no
Enable Output A...J	Reaction on closing the contact (rising edge)	ON
	Reaction on opening the contact (falling edge)	OFF
	Transmit object value after bus voltage recovery	<input type="radio"/> yes <input checked="" type="radio"/> no
	Debounce Time	50ms debounce time

This function is used, for binary inputs to which a switch or a push button is attached, to send a switching telegram (ON, OFF or TOGGLE) as a reaction to a rising and / or falling signal edge at this input. It has only 1 bit communication objects.

Debounce: Bouncing is the tendency of any two metal contacts in an electronic device to generate multiple signals as the contacts close or open; debouncing is any kind of hardware device or software that ensures that only a single signal will be acted upon for a single opening or closing of a contact.

A similar effect takes place when a switch made using a metal contact is opened. The usual solution is a debouncing device or software that ensures that only one digital signal can be registered within the space of a given time (usually milliseconds).

Short/Long Press: Distinguishing short from long presses is about measuring the pulse length. The event is no longer emitted upon pressing the button, but upon releasing it. This can affect the feeling of responsiveness.

The picture of this step shows a long press and short press timing, with a long press threshold of TI periods. The button press longer than Td period but shorter than TI period this mean is short pressed occurs.

Distinction between long and short operation	yes *no
---	-------------------

If the parameter is set no, the input will be evaluated normally on every edge of the input signal. Yes is selected. There is a delay after opening/closing the contact to determine whether there is a short or long operation.

Connected contact type	normally closed *normally open
-------------------------------	--

This parameter is visible if there is distinction between short and long operation. The contact type of the push button attached to the channel is adjusted here.

Cyclic transmission of object	*no "switch" = OFF "switch" = ON always
--------------------------------------	---

This parameter is visible if there is no distinction between short and long actuation. This parameter determines if and when a switching value is sent cyclically via the corresponding communication object.

Reaction on closing the contact (rising edge)	*ON OFF TOGGLE no reaction
--	--

This parameter is visible if there is no distinction between short and long actuation. This parameter determines the switching value to be sent when the contact is closed.

Reaction on opening the contact (falling edge)	ON *OFF TOGGLE no reaction
---	--

This parameter is visible if there is no distinction between short and long operation. This parameter determines the switching value to be sent when the contact is open.

7. COMMUNICATION OBJECTS (continued)

7.5 "Enable Input a...s" parameter (continued)

7.5.1 "a - Switch Sensor" parameter (continued)

Telegram is repeated every(transmission cycle time): base	100ms *1s 10s 1min 10min
--	---

This parameter determines the desired cycle time.

Period time: Base x Factor

Factor	2... *30 ...255
---------------	------------------------

Select time factor, between [2...255]

Reaction on short operation	*ON OFF TOGGLE no reaction
------------------------------------	--

This parameter is visible if there is distinction between short and long operation. This parameter determines the switching value to be sent when the contact is short press.

Reaction on long operation	ON *OFF TOGGLE no reaction
-----------------------------------	--

This parameter is visible if there is distinction between short and long operation. This parameter determines the switching value to be sent when the contact is long press.

Number of object for short/long operation	*1 object 2 object
--	------------------------------

This parameter is visible if there is distinction between short and long operation. Further communication object can be released by the option 2 communication objects.

Debounce time	*10ms ...50ms...150ms
----------------------	------------------------------

Debounce uses the input, which means checking twice in a short period of time to make sure it's definitely pressed.

7. COMMUNICATION OBJECTS (continued)

7.5 "Enable Input a...s" parameter (continued)

7.5.2 "a - Switch Dim Sensor" parameter

General	Connected contact type	<input type="radio"/> normally closed <input checked="" type="radio"/> normally open
Enable Input a...s	Dimming functionality	<input checked="" type="radio"/> only dimming <input type="radio"/> dimming and switch
a - Dim Sensor	Reaction on operation	Dim BRIGHTER
Enable Output A...J	Dimming mode	<input checked="" type="radio"/> start-stop-dimming <input type="radio"/> dimming steps
	Debounce time	50ms debounce time

You can use the corresponding input to switch the light on or off or dim it. When dimming, dimming up or dimming down is carried out via the 4 bit dimming object; the parameters for the dimming steps can be set. In addition, you can also transmit the corresponding dimming step cyclically for a period of time that can be set as required.

Connected contact type	normally closed *normally open
------------------------	--

The contact type of the push button attached to the channel is adjusted here.

Dimming functionality	Dimming and switching *Only dimming
-----------------------	---

- This parameter is select **"Dimming and switching"**;
- If the dimming actuator was switched on by a short push button action, then it is dimmed brighter/darker by the first long push button action.
- This parameter is select **"Only dimming"**;

The advantage of the "Only dimming" function is that no distinction is between short and long actuation. It is not necessary to wait for a long actuation.

Reaction on short operation	ON OFF *TOGGLE no reaction
-----------------------------	--

This parameter is visible if there is selected **"Dimming and switching"** operation.

When the push button is pressed briefly the value currently stored in the switching object. An ON or OFF telegram is only generated when the push button is released. (Falling edge)

Reaction on long operation	*Dim BRIGHTER Dim DARKER Dim BRIGHTER/DARKER
----------------------------	---

With the long push button action, the light becomes brighter or darker depending on the object value and the last controlled dimming direction.

A long operation changes the value of the object "Dimming".

Long operation after	*0,3s...10s
----------------------	--------------------

This parameter is visible if the parameter value is set "Dimming and switching". Long press period is select here.

Dimming mode	*start-Stop dim dimming steps
--------------	---

- "Start- Stop dim"**: It starts the dimming process with a telegram BRIGHTER or DARKER. In addition, button releases than STOP-dimming telegram sends. Cyclic sending telegram is not necessary in this case.
- "Dimming steps"**: The dimming telegram is sent cyclically during a long operation. STOP telegram sends at the end of operation.

Brightness change on every sent telegram	%100... *%6,25...%1,56
--	-------------------------------

This parameter is only visible with the "Dimming steps" options. This parameter is cyclically sent with every dim telegram.

7. COMMUNICATION OBJECTS (continued)

7.5 "Enable Input a...s" parameter (continued)

7.5.2 "a - Switch Dim Sensor" parameter (continued)

Transmission cycle time: Telegram is repeated every	0,3s... *0,5s...10s
--	----------------------------

This parameter is only visible with the **"Dimming steps"** options. The cycle time for sending corresponds with the time interval between two telegrams during cyclical sending.

Debounce time	10ms... *50ms...150ms
---------------	------------------------------

Debounce uses the input, which means checking twice in a short period to make sure it is definitely pressed.

7.5.3 "a - Blind Sensor" parameter

General	Operating functionality of blind	1-push-button, short = stepping, long = moving
Enable Input a...s	Connected contact type	<input type="radio"/> normally closed <input checked="" type="radio"/> normally open
a - Blind Sensor	Long operation after	0,4s
Enable Output A...J	Debounce time	30ms debounce time

The dual surface shutter function triggers shutter actuators, which can adjustment shutter and blind. You can rise the shutter/adjust the lamella using a single key and lower the shutter/adjust the lamella using a second key surface blind operation. Every shutter actuator controls with a 0-signal the up movement and a 1-signal down movement.

Operating functionality of the blind	*1 push-button, short=stepping, long=moving 1 push-button, short=moving, long=stepping 1 push-button-operation, moving 1 switch-operation, moving 2 push-button, standard 2 switch-operation, moving 2 push-button, moving 2 push-button, stepping
--------------------------------------	--

Description is below the table.

• 1 button, short=stepping, long=moving

Short operation	Stop / lamella adjustment The stop/lamella adjustment object is for the adjustment opposite direction to the last movement of the lamella. In additional it stops a running movement of the shutter.
Long operation	Shutter up / Shutter down Long press is opposite direction to the last movement for moving the shutter up or down.

• 1 button, short= moving, long= stepping

Short operation	Shutter up / Shutter down Long press is for moving the shutter up or down.
Long operation	Stop / lamella adjustment The stop/lamella adjustment object is for the adjustment opposite direction to the last movement of the lamella. In additional it stops a running movement of the shutter. Long press detects than stop/lamella adj. communication object sends periodically.

• 1 button operation, moving

On operation	This property is for moving only shutters up or down. Each press this commands send sequence: Move UP → Stop/lamella adj. UP → Move DOWN → Stop/ lamella DOWN
--------------	---

7. COMMUNICATION OBJECTS (continued)

■ 7.5 "Enable Input a...s" parameter (continued)
7.5.3 "a - Blind Sensor" parameter (continued)

Operating functionality of the blind	<p>*1 push-button, short=stepping, long=moving</p> <p>1 push-button, short=moving, long=stepping</p> <p>1 push-button-operation, moving</p> <p>1 switch-operation, moving</p> <p>2 push-button, standard</p> <p>2 switch-operation, moving</p> <p>2 push-button, moving</p> <p>2 push-button, stepping</p>
---	--

• 1 switch operation, moving

Start of operation	<p>This property is for moving only shutters up or down.</p> <p>While button is pressing, operation is continuing. This action is opposite direction to the last movement for moving the shutter up or down.</p>
End of operation	<p>When button releases, operation stop.</p> <p>Stop/ Lamella adj. command is send than movement stopped.</p>

With below functions, you must set the parameters for a second key (second input) with the corresponding settings for the shutter movement in the opposite direction.

• 2 button, standard

Short operation	<p>Stop / lamella adjustment</p> <p>The stop/lamella adjustment object is adjustment of the lamella UP or DOWN. In additional it stops a running movement of the shutter.</p>
Long operation	<p>This action is for moving the chosen direction shutter. Movement direction is choosing on parameter move up or moves down.</p>

• 2 switch operation, moving(shutter)

Start of operation	<p>This property is for moving only shutters up or down.</p> <p>While button is pressing, operation is continuing. This action is moving the shutter "move up" or "move down".</p>
End of operation	<p>When button releases, operation stop.</p> <p>"Stop/ Lamella adj. UP" or "Stop/ Lamella adj. DOWN" command is send than movement stopped.</p> <p>You should use the property with two switches.</p>

• 2 switch operation, moving(shutter)

On operation	<p>The property object "Shutter" is choose and performs the up- and down-movement of the shutter.</p> <p>The direction of movement depends to the parameters. When the button pressed firstly, than shutter move in direction that it was programmed. Second time button is pressed shutter stop command is sent such as STOP/ Lamella adj. UP or STOP/Lamella adj. DOWN.</p> <p>1) Shutter MOVE UP → STOP/Lamella UP</p> <p>2) Shutter MOVE DOWN → STOP/Lamella DOWN</p>
---------------------	---

• 2 button, stepping

On operation	<p>Stop / lamella adjustment</p> <p>The stop/lamella adjustment object is adjustment of the lamella UP or DOWN. Lamella move direction chooses on the parameters.</p>
---------------------	---

7. COMMUNICATION OBJECTS (continued)

■ 7.5 "Enable Input a...s" parameter (continued)
7.5.3 "a - Blind Sensor" parameter (continued)

Connected contact type	normally closed *normally open
-------------------------------	-----------------------------------

The contact type of the push button attached to the channel is adjusted here.

Reaction on short operation	*STOP/lamella UP STOP/lamella DOWN
------------------------------------	---------------------------------------

This parameter is visible if there is distinction between short and long operation.
Stop/step lamella adjustment parameter. This parameter object stops shutter movement.

Reaction on long operation	MOVE UP *MOVE DOWN
-----------------------------------	-----------------------

Distinction between short and long:
This parameter use for choose shutter movement direction.

Long operation after	0,3s...*0,4s...10s
-----------------------------	--------------------

Distinction between short and long:
Long press time period is select here.

Telegr. STOP/lamella adj. is repeated every	0,3sn...*0,4s...10sn
--	----------------------

Only visible 1 push-button, short=moving,
This parameter we choose each sending stop/lamella telegram-sending period. Lamella adjustment cyclically.

Debounce time	10ms...*50ms...150ms
----------------------	----------------------

Debounce uses the input, which means checking twice in a short period of time to make sure it's definitely pressed.

7.5.4 "a - Value/Forced Operation" parameter

You can use these value/forced functions to parameterize different object actions. You can transmit one or two objects short or long press status sequence, and select the size of the objects required (1 bit, 2-bit priority control, 1 byte, 2 byte or 4 byte) as needed. This enables you to parameterize a large number of application options. You can enter two values and set whether and how they are to be transmitted short or long.

Connected contact type	normally closed *normally open
-------------------------------	-----------------------------------

The contact type of the push button attached to the channel is adjusted here.

Distinction between long and short operation	yes *no
---	------------

If the parameter is set no, the input will be evaluated normally on every edge of the input signal.
Yes is selected. There is a delay after opening/closing the contact to determine whether there is a short or long operation.

7. COMMUNICATION OBJECTS (continued)

7.5 "Enable Input a...s" parameter (continued)

7.5.4 "a - Value/Forced Operation" parameter (continued)

Reaction on operation	no reaction 1-bit value 2-bit value (forced operation) *1 byte value [0...255] 2 byte [-32768...32767] 2 byte [0...65535] 4 byte (floating point) 4 byte value [0...4294967295]
------------------------------	---

This parameter is visible no distinction short/long operation;
This parameter determines the data type.
When button is pressed, this type of data sent KNX line with the communication object.

Reaction on short operation	no reaction 1-bit value 2-bit value (forced operation) *1 byte value [0...255] 2 byte [-32768...32767] 2 byte [0...65535] 4 byte (floating point) 4 byte value [0...4294967295]
------------------------------------	---

This parameter is visible distinction short/long operation; when button is pressed, this value sends KNX line on the communication object.

Transmitted value	*Dependent on the selection made at reaction on operation.
--------------------------	---

Short press value or on operation value is enter here.

Reaction on long operation	no reaction 1-bit value 2-bit value (forced operation) *1 byte value [0...255] 2 byte [-32768...32767] 2 byte [0...65535] 4 byte (floating point) 4 byte value [0...4294967295]
-----------------------------------	---

This parameter is visible distinction short/long operation;
This parameter determines the data type.
When button is pressed, this type of data sent KNX line with the communication object.

Transmitted value (long press)	* Dependent on the selection made at reaction on operation.
---------------------------------------	--

This parameter is visible distinction short/long operation;
Short press value or on operation value is enter here.

Long operation after: Time base	*250ms 1s 10s 1min 10min
--	---

This parameter is visible distinction short/long operation;
This parameter determines the desired long press time.

Period time: Base x Factor

Factor	1...*4...255
---------------	--------------

Select time factor, between [1...255]

Transmit object value after bus voltage recovery.	yes *no
--	-------------------

This parameter is visible no distinction short/long operation;
In the event of power supply failure to the electronics, the value (if this can be changed via a communication object) is permanently stored in a memory protected against data loss in the event of voltage failure. They are transferred from this memory into the working memory on bus voltage recovery.

Debounce time	10ms...*50ms...150ms
----------------------	----------------------

Debounce uses the input, which means checking twice in a short period of time to make sure it's definitely pressed.

7. COMMUNICATION OBJECTS (continued)

7.6 "Enable Output A...J" parameter

General	Output group A and B	shutter/blind DC
Weather Alarm	Output group C and D	no function
Enable Input a...s	Output group E and F	no function
Enable Output A...J	Output group G and H	no function
	Output group I and J	no function
A/B - General		
A/B - Drive Blind		
A/B - Drive Slat		
A/B - Function		
A/B - Scene		
A/B - Feedbacks		

Output group A and B	*no function shutter/blind DC fan coil valve control individually
-----------------------------	---

Both output group can be combined into one DC blind. In DC blind operation the four relay contacts of the device can be used to control electrically AC blind, shutter, awning, and venetian blind. Depending on this setting, all the group parameters and objects are created in the ETS.

- Set the parameter to **"no function"**
The parameter is selected output group A and B are invisible. You can not configured this channels.
- Set the parameter to **"shutter/blind DC"**;
The appropriate output quad is configured to DC blind. Four outputs are combined into one blind channel. In the blind mode four relay are locked against each other. The DC blind can be used to control electrically driven blinds, shutters, awnings and venetian blinds. DC blind operation page name starts with A/B, C/D prefix. The names of the output objects and the parameter page change accordingly.
- Set the parameter to **"fan coil"**:
The appropriate output three is configured to fan. Three outputs are combined into one fan channel. In the fan mode three relay are locked against each other. One output can not used by user.
- Set the parameter to **"valve control"**:
Valve control channel has a two valve. They can be configured separately 3-point or 2-point.
3-point valve drives are normally connected via three connection cables to the device: Neutral conductor, switched phase to OPEN, switched phase for CLOSE. Using 3-point control valve drives, the valve can be opened by any desired percentage and the position can be retained over an extended period. If the valve does not move, no voltage is applied to the motor.
2-point valve drives are controlled via the telegrams OPEN and CLOSE. The valve can only be completely open or completely closed.
- Set the parameter to "individually":
The parameter is selected "AC motor or switch" and the "Output group A" and "Output group B" parameters become visible. You can configured each output group separately.

Output group A	*shutter/blind AC 2 x switch
Output group B	* shutter/blind AC 2 x switch

The appropriate output pair is configured by this parameter.

- Set the parameter to **"shutter/blind AC blind"**:
The appropriate output pair is configured to AC blind. Two outputs are combined into one blind channel. In the blind mode two relay are locked against each other. The AC blind can be used to control electrically driven blinds, shutters, awnings and venetian blinds. AC blind operation page name starts with A, B, C and D prefix. The names of the output objects and the parameter page change accordingly.
- Set the parameter to **"2 x switch"**;
The appropriate output is configured to switch operation. Switch operation page name starts with A1, A2, B1... D1 and D2 prefix. The names of the output objects and the parameter page change accordingly.

7. COMMUNICATION OBJECTS (continued)

7.7 "Switch" parameter

7.7.1 "A1 - General" parameter

Contact type	*normally open normally closed
---------------------	-----------------------------------

The relays of a switching output can be parameterized as normally closed or normally open. This feature offers the possibility of inversion the switching state. Important: This state is only valid for switch communication object. Other relay function always works normally.

Normally closed contact

Switch state = off (0) → relay contact closed

Switch state = on (1) → relay contact open

Normally open contact

Switch state = off (0) → relay contact open

Switch state = on (1) → relay contact closed

Create status object "Status Switch"	no *yes
---	------------

If this parameter select 'yes', ETS create another communication object for use only status switch. The status object can be used to display the current output switching status on a display.

Send status after bus voltage return	*no yes
---	------------

You can use this parameter to send the switching state in the event of bus voltage recovery.

Behavior after ETS programming or after ETS reset	*keep position open contact close contact
--	---

After ETS programming, relay position set the wanted switching position.

• Set the parameter to "keep position"

In this setting, the relay remains in the current state. Any manual operation occurs in the meantime the switch actuator return its old position. The device doesn't know the status of the relay.

• Set the parameter to "open contact" or "close contact"

The relay contact open or close after bus voltage return.

Behavior bus voltage failure	*keep position open contact close contact
-------------------------------------	---

When the bus voltage fails, the device set the wanted switching state of the output. The relay can be open, close or keep position it occupied prior to the failure. At the same time, the current switching position of the relay is stored in the devices.

7. COMMUNICATION OBJECTS (continued)

7.7 "Switch" parameter (continued)

7.7.1 "A1 - General" parameter (continued)

Behavior bus voltage return	keep position open contact close contact *status as before bus voltage failure
------------------------------------	---

When the bus voltage returns, the device set the wanted switching state of the output.

• Set the parameter to "keep position"

In this setting, the relay remains in the current state. Any manual operation occurs in the meantime the switch actuator return its old position. The device doesn't know the status of the relay.

• Set the parameter to "open contact" or "close contact"

The relay contact open or close after bus voltage return.

• Set the parameter to "state as before bus voltage failure"

If the parameter set to "state as before bus voltage failure", then the relay is set to the value. The value stored at the time of the bus voltage failure.

7.7.2 "A1 - Function" parameter

Above function can be set for each channel. This function;

- Staircase function
- External logic
- Forced position
- Sweep function

Below you can find this functions description.

7.7.2.1 "A1 - Staircase Function" parameter

If you want to use staircase function, you must have been enabled 'Staircase' on the function windows. Than required parameters and communication, objects are visible. The staircase function can be parameterized for each channel.

Staircase function has a three communication object. These are "Enable staircase function", "Staircase lighting duration" and "Permanent ON".

7. COMMUNICATION OBJECTS (continued)

7.7 "Switch" parameter (continued)

7.7.2 "A1 - Function" parameter (continued)

7.7.2.1 A1 - Function" parameter (continued)

Duration of staircase lighting [min]/ [sec]	0...*5...240[min] *0...59 [sec]
---	------------------------------------

Staircase function on time is calculated by "duration of staircase lighting". Staircase lighting time is defined by this parameter. At the end of the on time, the relay off or active the staircase warning functions.

Staircase retrigger	*not retriggerable yes retriggerable up to staircase lighting time 2x up to staircase lighting time 3x up to staircase lighting time 4x up to staircase lighting time 5x
---------------------	---

This parameter defines whether the staircase on time can be retriggerable or not so the on time can be extended by 'Enable staircase function'. You can repeat retrigger function until the repeater count reached the maximum value (2x, 3x, 4x, 5x). If the parameter selects "not retriggerable", staircase on time doesn't extend.

Reaction to OFF telegram	*switch off ignore
--------------------------	-----------------------

After this parameter selected "switching off", "ignored". Enable staircase function' communication object 'disable' command.

Staircase time can be changed by object	yes *no
---	------------

"Staircase lighting duration" communication object is visible if a "Staircase time can be changed by object" parameter selects "yes". This communication object is 2 byte. The value defines the staircase on time in second.

NOTE: After a bus voltage fails, staircase on time returns default value (Duration of staircase lighting).

Restart staircase after "Permanent ON"	yes *no
--	------------

If this parameter is selected "yes", receive "Permanent ON" communication object after restart staircase function.

Activate pre-warning time?	yes *no
----------------------------	------------

The warning function can be activated by this parameter select "yes". Then, you can adjust pre-warning time, number of pre-warning and time for pre-warning interval. The warning function is for warning that the staircase lighting time run out and the lights are switched off soon. In the warning, lights short turn off. Switch status is ON until finish warning time.

Pre-warning time Minutes (0...59) Second (0...59)	*0...59 0...*30...59
--	-------------------------

How long the lights shall be switched on in the period.

Number of pre-warning (1...10)	1...*2...10
--------------------------------	-------------

Enter the number of how many blink doing in the warning.

Time for pre-warning intervals Seconds (0...59)	0...*3...59
--	-------------

How long the lights shall be switched off in the period.

Activate on delay	yes *no
-------------------	------------

This parameter is used delay to switch off position before staircase start.

7. COMMUNICATION OBJECTS (continued)

7.7 "Switch" parameter (continued)

7.7.2 "A1 - Function" parameter (continued)

7.7.2.2 "A1 - External logic" parameter

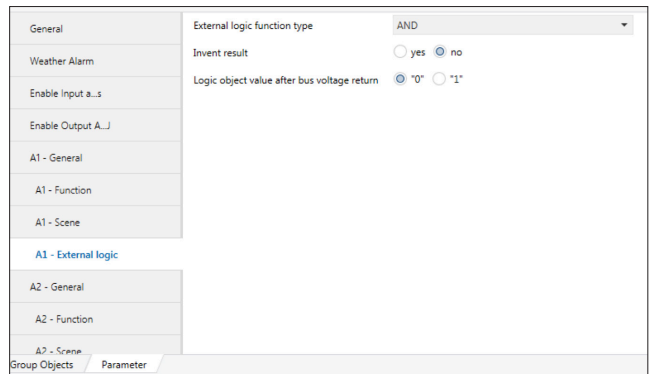

Logic function can be used independently for each output. With this function, the 'Switch' object can be logically linked with the "External logic input". Channel relay switch a result of the logic operation. For example, "Switch" object value 1 and "External logic input" object value 0 relay switch as a result of 1 & 0 operation.

External logic function type	*AND OR XOR
------------------------------	-------------------

This parameter selects the type of logic function between "Switch" and "External logic input" objects.

Invert result	yes *no
---------------	------------

If you want to inverted logic function result, you should select "yes".

Logic object value after bus voltage return	"1" *"0"
---	-------------

This parameter defines the value of the "External logic input" object after bus voltage return.

Note:

The values of the "External logic" communication objects doesn't store at the bus voltage failure.

7.7.2.3 "A1 - Sweep" parameter

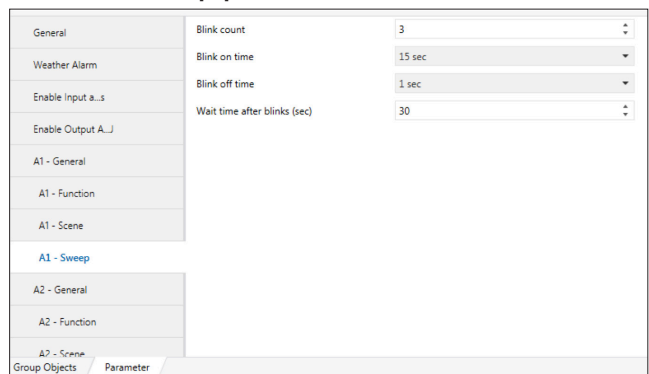

Sweep function only starts to operate if the relay is switched ON. It's an alternative way for turning off the relay with pre-warning. The sweep function is desired to warn a person that lights will go out shortly.

Send counter value	1...*3...10
--------------------	-------------

The lamps connected to the relay will be switched off as many times. Enter the number of how many blink doing in the warning.

Blink on time	0,5sec...*1sec...5sec
---------------	-----------------------

How long the lights shall be switched on in the period.

7. COMMUNICATION OBJECTS (continued)

7.7 "Switch" parameter (continued)

7.7.2 "A1 - Function" parameter (continued)

7.7.2.3 "A1 - Sweep" parameter (continued)

Blink off time	*300ms...1sec
-----------------------	---------------

How long the lights shall be switched off in the period.

Wait time after blinks (sec)	0...*30...255
-------------------------------------	---------------

How long the lights shall be switched on after sweep blink finished.

7.7.2.4 "A1 - Scene" parameter

For more information please look scene, page 7.

7.8 "Blind" parameter

7.8.1 "A/B – General" parameter

In this parameter page, general settings for blinds (AC blind or DC blind) are explained. Parameters for both types is the same.

Mode of operation	*venetian blind roller shutter / awning
--------------------------	--

This parameter defines the operating of the output group. Each output of the group can be configured independently for the drive type. The communication object and parameters for the respective outputs differ on the mode of operation. The ETS adapts the parameters and communication object for all group.

- Set the parameter to "venetian blind":
In this mode, there are also parameters and objects for slat operation.
- Set the parameter to "roller shutter / awning":
In this mode, there is no slat control so slat parameters and object automatically hiding by the ETS3.

7. COMMUNICATION OBJECTS (continued)

7.8 "Blind" parameter (continued)

7.8.1 "A/B – General" parameter (continued)

Behavior after ETS programming or after ETS reset Behavior bus voltage failure	*no reaction up down stop position 1,2,3,4 approach position
---	---

This parameter can be used to configure the blind behavior after ETS programming.

- Set the parameter to "no reaction":
The output group switch remain in their current state.
- Set the parameter to "up":
After the ETS programming, the actuator raises the blind.
- Set the parameter to "down":
After the ETS programming, the actuator lowers the blind.
- Set the parameter to "stop":
After the ETS programming, the actuator stops the blind movement.
- Set the parameter to "position 1,2,3,4":
The blind move to a present position. The positions are set in the "X - Position/Preset" tabs .
- Set the parameter to "approach position":
The blind can travel to an approach position specified by other parameters. Other parameters are;

Position height in [0...100]
(0% = top; 100% = button)

Position slat in [0...100]
(0% = top; 100% = button).

This parameters are configured the blind height and slat position. If the "Mode of operation" is selected "venetian blind", "Position slat in [0...100]" parameters are visible.

Behavior bus voltage return	*no reaction up down stop
------------------------------------	------------------------------------

This parameter can be used to configure the blind behavior after bus voltage return.

- Set the parameter to "no reaction":
The output group switch remain in their current state.
- Set the parameter to "up"/
After the bus voltage return, the actuator raises the blind.
- Set the parameter to "down":
After the bus voltage return, the actuator lowers the blind.
- Set the parameter to "stop":
After the ETS programming, the actuator stops the blind movement.

7. COMMUNICATION OBJECTS (continued)

■ 7.8 "Blind" parameter (continued)

7.8.2 "A/B – Drive Blind" parameter

General	Travel time UP in s[0...6000]	60
Weather Alarm	Travel time DOWN in s[0...6000]	60
Enable Input a...s	Disconnect output from power after	end position, no overflow
Enable Output A...J	Enable communication object "Trigger reference movement" 1 bit	<input type="radio"/> enable <input checked="" type="radio"/> disable
A/B - General	Limit travelling range	<input type="radio"/> no <input checked="" type="radio"/> via object "Blind/shutter up down limited"
A/B - Drive Blind	Pause on change in direction (1-255 factor * 100ms)	5
A/B - Drive Slat	Delay times for drive	<input checked="" type="radio"/> standart <input type="radio"/> user defined
A/B - Function	Difference between coasting delay and start-up delay in ms[-128...127]	0
A/B - Scene	Minimum run time for drive in ms[10...255]	50
A/B - Position/Preset		
A/B - Feedbacks		

The blind actuator calculates the current position of a blind from the running time. This calculation has to be performed because the drive cannot provide any feedback on its position.

Detect travel times (Up/Down)	via detection of end position *set travel times
--------------------------------------	--

This parameter defines the travelling time of the blind. The time needed for a complete travel from the upper into the lower end position.

- Set the parameter to "**via detection of end position**":
The duration of the current flow that the drive uses for the movement from lower to the upper position. The device is measured the travel time with current detection. Than up down movements are stored.
- Set the parameter to "**set travel times**":
This option is an alternative to automatic travel detection. In this way, travel times for the lower to the upper end position are measured with a stop watch then entered into the ETS parameters. The travel times should be measured as precisely as possible because this times is determined during ongoing operation.

Travel time UP in s[0...6000]**Travel time DOWN in s[0...6000]**

If the "**Detect travel times (Up/Down)**" is selected "**set travel times**", this parameters are visible. The measured travel time values are measured via stopwatch then enter this parameter.

Disconnect output from power after	*end position, no overflow end position + %2 overflow end position + %5 overflow end position + %10 overflow end position + %20 overflow total travel time + %10 overflow
---	--

When the blind has been reached the end position (this means top or bottom position), the blind is switched off its relay. An overflow time can be set to ensure the output safely reaches the end position. The voltage is supplied as an extra time after the blind has been switched off.

Enable communication object "Trigger reference movement" 1 bit	enable *disable
---	--------------------

If the parameter is selected "**enable**", "**Trigger reference movement**" communication object is visible. The reference movement is triggered via this communication object. In long time, slight inaccuracies can occur so the upper and lower end positions are used for unique determination of current position. A position calibration is possible by executing the reference movement. A reference travel movement is not re-triggerable.

7. COMMUNICATION OBJECTS (continued)

■ 7.8 "Blind" parameter (continued)

7.8.2 "A/B – Drive Blind" parameter (continued)

Position after travel detection	*no reaction, remain in upper end position move to position before travel detection
--	--

If the "**Detect travel times (Up/Down)**" is selected "**set travel times**", this parameters are visible. This parameter is configured the blind position after the reference movement. The step or stop telegram are ignored while the blind is moving in the reference movement.

Limit travelling range	*no via object "Blind/shutter up down limited" via object "Enable limitation"
-------------------------------	---

The blind up and down limit position can be changed by this parameter.

The limit position only apply for "**Move blind/shutter up-down**", "**Slat adjustment/stop up-down**" and automatic communication objects.

Upper limit in % [0...100] (0% = top; 100% = bottom)	*0...100
Lower limit in % [0...100] (0% = top; 100% = bottom)	0...*100

If the "**Limit travelling range**" parameter is selected "**via object "Blind/shutter up down limited"**", this parameter is visible. This parameter set the blind upper/lower limit position in percent.

Pause on change in direction (1-255 factor * 100ms)	1...*5...255
--	--------------

When the blind actuator of a drive that is currently moving, receives a command to move opposite direction. The blind firstly stops than its waits for the pause on change in direction than the blind is moved its new direction.

Delay times for drive	*standard user defined
------------------------------	---------------------------

If the parameter is selected "**user defined**", these parameters are visible. You can show this below.

Different between coasting delay and start-up delay in ms[-128...127]	-128...*0...127
--	-----------------

If the blind is closed lower end position, the used blind experiences dead time between the times when the blind is started the movement. You can compensate this time with this parameter.

Minimum run time for drive in ms[0-255]	0...*50...255
--	---------------

The blinds have a minimum run time. Please look drive manufacturer datasheet.

7. COMMUNICATION OBJECTS (continued)

7.8 "Blind" parameter (continued)

7.8.3 "A/B – Drive Slat" parameter

Determine times for slat *via duration of slat adjustment (step) via total duration for slat turning

This parameter defines the slat moving time configuration.

Duration to turn slat from 0% - 100% in ms [50...60000]	50...*1500...60000
Duration of slat adjustment (step) in ms [50...1000]	50...*200...1000

These parameters define the travelling time of the slat. The time needed for a complete movement or step movement. Sets the millisecond of the slat moving time.

Number of slat adjustments (from 0% = open to 100% = closed)	1...*7...60
---	-------------

This parameter defines the number of slat steps. The slat steps are required to turn the slats from fully closed to fully opened.

Limit step commands to number of slat adjustment	*no yes
---	------------

This parameter defines the limit step adjustment command. If it selected "no", the slat adjustment step count is unlimited.

Position of slat after arriving on lower end position (100% = disable)	0...*100
---	----------

The blind will set the slat according to the parameterized value, after the end position is reached. This parameter is valid for move up down communication object.

7.8.4 "A/B – Functions" parameter

All outputs can be parameterized independent of one other. These parameters are only visible in blind operation.

- Enable position/presets
- Weather alarm
- Forced position
- Feedbacks

The functions are described independently in detail below.

7. COMMUNICATION OBJECTS (continued)

7.8 "Blind" parameter (continued)

7.8.4 "A/B – Functions" parameter (continued)

7.8.4.1 "A/B – Position/Presets" parameter

This function allows you set a height position or slat position, directly using with communication object.

Enable communication objects "Move to pos. Height/Move slat 0...255"	*no yes
---	------------

The communication "Move to position height 0...255" and "Move slats 0...255" allow you to set the absolute position values. The height position object is responsible for the height position of blind. The slat position object is responsible for the slat-opening angle. The limit position %0 means the blind fully up or slat closed up, %100 means the blind fully down or slat closed down.

Enable communication objects "Move to/set position 1-4" 1 bit	*no yes
--	------------

If the parameter selected "yes", "Move to position 1, 2", "Move to position 3, 4", "Set position 1, 2", and "Set position 3, 4" 1-bit telegrams are enabled. The saved or downloaded position can be easily changed or called with this communication object. The new position is accepted into the devices memory via "Set position" communication objects.

Overwrite position values during download	*no yes
--	------------

This parameter is selected the reaction of the position set.

- Set the parameter to "no":
During storage of a scene, the position values are stored in the device. You can protect your custom blind position.
- Set the parameter to "yes":
The original ETS parameter values can be reload into the device during ETS download operation.

Position 1: Height in % [0...100] (0% = top; 100% = bottom)	0...*20...100
Position 1: Slat in % [0...100] (0% = top; 100% = bottom)	0...*20...100
Position 2: Height in % [0...100] (0% = top; 100% = bottom)	0...*40...100
Position 2: Slat in % [0...100] (0% = top; 100% = bottom)	0...*40...100
Position 3: Height in % [0...100] (0% = top; 100% = bottom)	0...*60...100
Position 3: Slat in % [0...100] (0% = top; 100% = bottom)	0...*60...100
Position 4: Height in % [0...100] (0% = top; 100% = bottom)	0...*80...100
Position 4: Slat in % [0...100] (0% = top; 100% = bottom)	0...*80...100

These parameters define the blind preset height/slat position. Slat positions are only visible when the blind type is selected "Venetian blind".

7. COMMUNICATION OBJECTS (continued)

7.8 "Blind" parameter (continued)

7.8.3 "A/B – Weather alarm" parameter (continued)

Move to position	<p>*directly indirectly via upper end position indirectly via lower end position indirectly via shortest way</p>
------------------	---

This parameter is set to the blind how to go to the target position.

- Set the parameter to **"directly"**:
The blind moves to target position directly.
- Set the parameter to **"indirectly via upper/lower end position"**:
After the blind moves the upper/lower end position, the blind moves to target position.
- Set the parameter to **"indirectly via shortest way"**:
Firstly, the blind moves the shortest end position and then the blind moves to target position directly.

7.8.4.2 "A/B – Position/Presets" parameter

The weather functions must first be globally enabled before they can be parameterized and used. After general weather function is enabled, the weather alarm can be enabled or disabled independently of one other. The reaction at beginning of an alarm telegram is received "1". Alarm function is terminated as soon as a new alarm telegram is received "0".

Assignment to wind alarms	yes
Assignment to rain alarms	*no
Assignment to frost alarms	

There are three different wind alarms available. These alarms can be used for instance, to protect Venetian blind or awning. The blind is also assigned to multiple wind alarm. The three wind alarms have the same priority. These are respect to one other with logic OR.

7. COMMUNICATION OBJECTS (continued)

7.8 "Blind" parameter (continued)

7.8.3 "A/B – Weather alarm" parameter (continued)

7.8.4.2 "A/B – Position/Presets" parameter (continued)

<p>Behavior in case of wind alarm Behavior in case of rain alarm Behavior in case of frost alarm</p>	<p>*no reaction up down stop position 1 position 2 position 3 position 4 individual position</p>
--	---

When the alarm is activated, the blind moves this position.

- Set the parameter to **"no reaction"**:
At the beginning of the wind alarm, the relay of blind shows no reaction. Any movements in progress at instant will still be completely finished.
- Set the parameter to **"up"**:
The devices raises the blind at the beginning of the wind alarm or wind alarms then the outputs are locked.
- Set the parameter to **"down"**:
The devices lowers the blind at the beginning of the wind alarm or wind alarms then the outputs are locked.
- Set the parameter to **"stop"**:
At the beginning of the alarm the device switches the relay of output to stop then the outputs are locked.
- Set the parameter to **"position 1, 2, 3, 4"**:
The blind move to the preset position when the alarm is activated. The position parameters set in the **"A – Position/Preset"** tag.
- Set the parameter to **"individual position"**:
The blind moves to individual position. Individual position can be set this parameters.

Position height in [0...100]
(0% = top; 100% = button)

Position slat in [0...100]
(0% = top; 100% = button).

This parameters are configured the blind height and slat position. If the **"Mode of operation"** is selected **"venetian blind"**, **"Position slat in [0...100]"** parameters are visible.

Order of priority for safe	<p>*1.Weather alarm – 2.Block – 3.Forced 1.Weather alarm – 2.Forced – 3.Block 1. Block – 2. Weather alarm – 3. Forced 1. Block – 2. Forced – 3. Weather alarm 1. Forced – 2. Weather alarm – 3.Block 1. Forced – 2. Block – 3. Weather alarm</p>
----------------------------	---

This parameter defines the order of the safe function priority. In this way, the blind correctly controlled if more than one safety function is activated simultaneously. Priority level decreases from the first to the last. Weather alarm is contain the wind 1, 2, 3, rain, frost. Their priority can be configured in the "Weather Alarm" main tag; the parameter name is **"Order of priority for weather"**.

7. COMMUNICATION OBJECTS (continued)

7.8 "Blind" parameter (continued)

7.8.3 "A/B – Weather alarm" parameter (continued)

7.8.4.3 "A/B – Forced position" parameter

The forced position function can be used for each output. The forced position function has a 1 bit or 2 bit optional communication object. The blind can be moved up or down via forced operation telegram (1 bit or 2 bit). Forced position function can be used for blind cleaning time. It can protect the person for unexpected accident.

Bit 1	Bit 0	Function
0	x	Forced position not active normal control
0	x	Forced position not active normal control
1	0	Forced position active, raising / opening the louver
1	1	Forced position active, lowering / closing the louver

Forced operation (1bit/2bit)	*activated (1bit) activated (2bit)
------------------------------	---------------------------------------

The blind can be moved with forced operation to desired position via 1 bit telegram. Also using 2 bit telegram, the blind can be moved up or down. The movement is stopped when the blind reached at the end position.

Position height in [0...100]
(0% = top; 100% = button)

Position slat in [0...100]
(0% = top; 100% = button).

This parameters are configured the blind height and slat position. If the "Forced operation (1bit/2bit)" is selected "activated (1bit)", "Position height/slat in [0...100]" parameters are visible.

Behavior after bus voltage return	*no forced position active forced position ON, raising forced position ON, lowering state of forced pos. before bus volt. fail.
-----------------------------------	--

The forced position function can be initialized after bus voltage return so the forced operation communication object is updated. After the bus voltage return, forced position function set to the parametrized position.

- Set the parameter to "no forced position active":
The forced operation is deactivated after bus voltage return.
- Set the parameter to "forced position ON raising/lowering":
The forced operation active and the blind rising/lowering after bus voltage return.
- Set the parameter to "state of forced pos. before bus volt. fail":
After bus voltage return, the forced position state last selected and internally stored in the device. ETS download operation deletes the stored state.

7. COMMUNICATION OBJECTS (continued)

7.8 "Blind" parameter (continued)

7.8.3 "A/B – Weather alarm" parameter (continued)

7.8.4.4 "A/B – Feedbacks" parameter

Height and slat position status	*no yes
---------------------------------	------------

The blind position of the output can be reported to the KNX bus. The communication object value is 0 to upper (%0) position of blind. The communication object value is 255 to lower (%100) position of blind. "Status height 0...255" and "Status slat 0...255" communication objects are created and then the blinds height and slat status send with this objects.

transmit mode	after change after request *after change or request
---------------	---

This parameter is selected the communication object transmit mode which means object flag is adjusted.

Upper and lower end position status	*no yes
-------------------------------------	------------

If the blind is in the upper or lower end position, communication object telegram is sent. "Status upper end position" and "Status lower end position" communication objects are created and then the blinds reached the limit position send with these objects.

transmit mode	after change after request *after change or request
---------------	---

This parameter is selected the communication object transmit mode which means object flag is adjusted.

7.8.4.5 "A/B – Scene" parameter

For more information please look scene, page 7.

7. COMMUNICATION OBJECTS (continued)

7.9 "Valve Control" parameter

7.9.1 "A/B – Control Input" parameter

HVAC system	<ul style="list-style-type: none"> *one control four pipe with switch two control two pipe two control two pipe with switch two control four pipe
--------------------	---

This parameter is used to select the fan coil pipe system for valve operations.

- Set the parameter to **"one control four pipe with switch"**:
In this system contains HEATING and COOLING exchangers. 2 pipes for warm water and other 2 pipes for cold water. One communication object is used to HEATING or COOLING. It can be set via **"Toggle HEATING/COOLING"** communication object.
- Set the parameter to **"two control two pipe"**:
In this system contains only HEATING exchangers. 2 pipes is used for HEATING or COOLING. Both objects are used to for HEATING valve. The last value is considered valid if it comes from which object.
- Set the parameter to **"two control two with switch"**:
In this system contains only HEATING exchangers. 2 pipes is used for HEATING or COOLING. Both objects are used to for HEATING valve. Active communication object can be select via **"Toggle HEATING/COOLING"** communication object.
- Set the parameter to **"two control four pipe"**:
In this system contains HEATING and COOLING exchangers. 2 pipes for warm water and other 2 pipes for cold water. Each communication objects are managed the related valve. The same time only one valve can be opened. The other one is set to %0 percentage.

Operation HEATING/COOLING after bus voltage recovery	<ul style="list-style-type: none"> *unchanged bus return heating cooling
---	---

This parameter is used to select reaction after bus voltage recovery.

Object value for HEATING the object "Toggle HEATING/COOLING"	<ul style="list-style-type: none"> 0 *1
---	---

This parameter is used to which communication object value used for HEATING.

- Set the parameter to **"0"**:
When the telegram is received **"0"**, HEATING operation is activated. (COOLING is deactivated)
- Set the parameter to **"1"**:
When the telegram is received **"1"**, HEATING operation is activated. (COOLING is deactivated)

Monitoring control valves	<ul style="list-style-type: none"> yes *no
----------------------------------	--

This parameter activate the thermostat monitoring. If the parameter selected enable, Monitoring period time in s [30...65535] parameter is visible.

7. COMMUNICATION OBJECTS (continued)

7.9 "Valve Control" parameter (continued)

7.9.1 "A/B – Control Input" parameter (continued)

Monitoring period time in s[30...65535]	30...*120...65535
--	-------------------

The telegram of the active thermostat can be monitored cyclically. The device then expect a telegram from the thermostat within the cycle time.

Send object value ("Control value fault" 1 bit)	<ul style="list-style-type: none"> no *after change after request after change or request
--	---

If the telegram is not received within the monitoring period time, it can be assumes that the sensor is break or bus line interrupted. This object is sent the KNX bus.

The "Control value fault" can be used as an active or passive communication object. Active message object, the switch status telegram is transmitted to the bus automatically when a state changes. Passive status object, there is no telegram transmission after state changes. If you want to learn switch status, you must read communication object. Communication object flags are automatically set by ETS.

Enable control value after fault	<ul style="list-style-type: none"> yes *no
---	--

This parameter activate the fault condition after fault operation. If the parameter selected yes, Control value after fault in % [0...100] parameter is visible.

Control value after fault in %[0...100]	0...*30...100
--	---------------

After the fault operation occurred in emergency state, the valve can be set the valve fault percentage.

7.9.2 "A – Valve General" parameter

Valve control	<ul style="list-style-type: none"> *two point on/off three point open/close
----------------------	---

This parameter can be used to select the properties of valve type.

Valve contact type	<ul style="list-style-type: none"> *normally open normally closed
---------------------------	---

This parameter is used to select reaction after bus voltage recovery.

Observe reversing time	<ul style="list-style-type: none"> no 100 ms *300 ms 500 ms 700 ms 1000 ms
-------------------------------	--

This parameter defines the reversing delay time of the valve drive. If the valve control parameter is selected three point open/close, this parameter is visible.

7. COMMUNICATION OBJECTS (continued)

■ 7.9 "Valve Control" parameter (continued)

7.9.2 "A – Valve General" parameter (continued)

Valve position [0...100]%	*0...100
---------------------------	----------

This parameters are configured the blind height and slat position.

Valve contact type	*normally open normally closed
--------------------	-----------------------------------

This parameter is used to select reaction after bus voltage recovery.

Value control duration from 0...100% in s [10...6000]	0...*180...6000
---	-----------------

With this parameter, a time is set in seconds that the connected valve requires to move from position 0 % (valve closed) to position 100 % (valve fully open). If the valve control parameter is selected three point open/close, this parameter is visible.

For example, the time is 180s, the current valve position is at 20%, the target position is 60%, and then the travel time of the valve will need 72s from 20% to 60%.

Automatically adjust valve position in s [10...6000]	*no yes
--	------------

This function is mainly used to correct the valve position, for example, the valve is not fully opened or closed after long working hours due to various reasons lead to the valve position slight inaccuracies, such temperature, aging of the device etc. So it needs to be repositioned via the function. If the valve control parameter is selected three point open/close, this parameter is visible.

Number of valve control up to adjustment [1...65535]	1...*100...65535
--	------------------

This parameter is selected automatic adjustment threshold which automatic adjustment is undertaken. Assuming that the parameterized value is 100, when the number of valve controls arrived to 100, if the valve is adjusted to the opening direction on the 101st adjustment, then the automatic adjustment is not executed, if to the closing direction, the automatic adjustment will be executed, and the valve is adjusted to the position 0%, and then adjusted to the target position. For example, on the 100st the valve position is 50%, if the 101st the valve position is 60%, the valve position is adjusted directly to 60% and do not execute an automatic adjustment until a reversal control value is received. If the 101st the valve position is 40%, an automatic adjustment is undertaken and the valve is adjusted to the position 0%, and then adjusted to the target position 40%. The automatic adjustment is exceeded the closing position by % 5 of the total travel time. This time is maximum one minute.

Valve limitation	yes *no
------------------	------------

The limitation of the control value limits the height of the control value. The limitation is activated, when a value is chosen which is smaller/higher than the possible value for the control value, so minimum larger than 0 or maximum smaller than 1. If an input signal is out of the adjusted limitation, it will be decreased or increased.

Example: At the heating mode, the maximum limit is chosen as 70% and the minimum limit is chosen as 10%. The valve opening is adjusted as 10min. If a control value is sent as 100% for the input, the channel takes the maximum limit of 70% and calculates from this value the on-pulse as 7min. A control value in the limitations works normal, so a control value of 50% creates an on-pulse of 5min

7. COMMUNICATION OBJECTS (continued)

■ 7.9 "Valve Control" parameter (continued)

7.9.3 "A – Function" parameter

General	Enable communication object "Block" 1bit	<input type="radio"/> yes <input checked="" type="radio"/> no
Weather Alarm	Enable communication object "Forced operation" 1bit	<input type="radio"/> yes <input checked="" type="radio"/> no
Enable Input a..s	Enable communication object "Valve position status"	no
Enable Output A..J	Enable valve purge	<input checked="" type="radio"/> yes <input type="radio"/> no
A/B - Control Input	Enable communication object "Status valve purge" 1bit	<input checked="" type="radio"/> yes <input type="radio"/> no
A - Valve General	Send object value	no
A - Function	Duration of valve purge in min [1..255]	10
B - Valve General	Automatic valve purge	<input checked="" type="radio"/> yes <input type="radio"/> no
B - Function	Purge cycle in weeks [1..12]	6

Enable communication object "Block" 1 bit	yes *no
---	------------

A channel can be blocked for further operations by its blocking object. While valve is moving, block object is activated the valve finished its move.

Block on object value	*1 0
-----------------------	---------

1: The blocking is triggered by sending a logical "1" at the belonging block object. Only through sending a logical "0", the channel is unblocked again.

0: The blocking is triggered by sending a logical "0" at the belonging block object. Only through sending a logical "1", the channel is unblocked again.

Enable communication object "Forced operation" 1 bit	yes *no
--	------------

The forced position drives the control value to a fixed position.

Forced operation on obj value	*1 0
-------------------------------	---------

1: A logical "1" activates the forced position. By sending a logical "0", the forced position is deactivated

0: A logical "1" activates the forced position. By sending a logical "0", the forced position is deactivated and the channel goes back to its last value or the last received telegram for the control value.

Value position on forced operation In % [0...100]	0...*30...100
---	---------------

This parameter determines the valve position after forced operation activates.

Enable communication object "Valve position status"	*no 1 bit 1 byte
---	------------------------

This parameter is select sends/responds the actual value of the valve percentage. The valve status object is sent as soon as possible after the control value is received.

Send object value	*no after a change after request after change or request
-------------------	---

The parameter is selected object send type.

Duration of valve purge In min [1...255]	1...*10...255
--	---------------

If the valve purge is activated, the actuator opens the corresponding valve for a period.

Automatic valve purge	yes *no
-----------------------	------------

Automatic control can be enabled with this parameter.

7. COMMUNICATION OBJECTS (continued)

■ 7.9 "Valve Control" parameter (continued)

7.9.3 "A – Function" parameter (continued)

Purge cycle in weeks [1...12]	1...*6...12
-------------------------------	-------------

If the "Automatic valve purge" parameter is selected "yes", this parameter is visible. The purge cycle is started automatically after initialization of the actuator. If the valve isn't actuated for a period of the adjusted time, then the actuator open the corresponding valve for a period of 5 minute.

7.9.4 "A – Limit" parameter

General	Min. limit of control value	0
Weather Alarm	Min. limit of valve position	0
Enable Input a...s	Max. limit of control value	100
Enable Output A...J	Max. limit of valve position	100
A/B - Control Input		
A - Valve General		
A - Function		
A - Limit		
B - Valve General		
B - Function		

Min. limit of control value % [0...100]	*0...100
---	----------

The parameter adjust the minimum limit of the control value.

Min. limit of valve position % [0...100]	*0...100
--	----------

The parameter adjust the minimum limit of the valve position.

Max. limit of control value % [0...100]	*0...100
---	----------

The parameter adjust the maximum limit of the control value.

Max. limit of valve position % [0...100]	*0...100
--	----------

The parameter adjust the minimum limit of the valve position.

7. COMMUNICATION OBJECTS (continued)

■ 7.10 "Fan Coil" parameter

7.10.1 "Fan" parameter

General	Enable communication object "Status fan speed x" 1 bit	<input type="radio"/> yes <input checked="" type="radio"/> no
Weather Alarm	Enable communication object "Status fan speed" 1 byte	<input type="radio"/> yes <input checked="" type="radio"/> no
Enable Input a...s	Enable communication object "Status fan ON/OFF" 1 bit	<input type="radio"/> yes <input checked="" type="radio"/> no
Enable Output A...J	Enable communication object	<input type="radio"/> yes <input checked="" type="radio"/> no
A/B1 - Fan		
A/B1 - Status Message		
A/B1 - Automatic Operation		
A/B1 - Direct Mode		

Select valve with working	*valve A/B valve C/D valve E/F valve G/H valve I/J
---------------------------	--

This parameter is used to select valve channel working with automatic mode. Selected valve channel control value input object also used for fan level in the automatic mode.

Number of fan levels	1...*3
----------------------	--------

The fan level can be selected to the specific fan coil application required by means of parameter configurations. Thus, initially the number of fan levels required for the connected devices can be defined. The number of fan levels can be specified separately for each fan coil channel.

Controlling the fan levels	*only one fan output switches fan outputs switch hierarchically
----------------------------	--

The change-over principle: When a fan is switched on, there is always only one fan level output active "ON". If the active fan level is changed, the fan coil actuator first switches the previously switched-on fan level off ("OFF" state), and only after that switches the other output on.

The level principle: When a fan is switched on, several outputs are switched on, depending on the active fan level. When the fan level is increased, the adjacent output with the next higher output number is also switched on; the lower outputs remain switched on.

Fan operation mode	*changeover switch step switch
--------------------	-----------------------------------

This parameter can be used to select the properties of fan. Please look the fan technical data.

- Set the parameter to "changeover switch":
In this mode delay between two fan speeds. This delay time can be configured via delay between fan speed switching in ms [50...5000] parameter.
- Set the parameter to "step switch":
In this mode current fan speed must be switched on for a least time before the new fan speed is switched on.

Delay between fan speed switching in ms [50...5000]	50...*500...5000
---	------------------

If the Fan operation mode parameter is selected "changeover switch", this parameter is visible. This parameter is used to configure the fan delay time. This time is using between the fan speed switching.

Fan speed on bus voltage failure	unchanged *off 1 2 3
----------------------------------	----------------------------------

Using this parameter, the fan reaction can be set after bus voltage failure is set.

7. COMMUNICATION OBJECTS (continued)

7.10 "Fan Coil" parameter (continued)

7.10.1 "Fan" parameter (continued)

Fan speed on bus voltage recovery	unchanged *off 1 2 3
-----------------------------------	----------------------------------

Using this parameter, the fan behavior is defined after bus voltage recovery is set.

Enable forced operation	yes *no
-------------------------	------------

This parameter is used to enable fan-forced operation.

Forced operation on object value	0 *1
----------------------------------	---------

This parameter is selected which value is activated the forced operation.

Limitation on forced operation	3, 2, 1, OFF *unchanged ...
--------------------------------	-----------------------------------

This parameter is selected the forced operation behavior.

Enable automatic operation	*yes no
----------------------------	------------

This parameter can be enabled the automatic control. Automatic control meaning is limited reaction according to "Control input".

Enable direct operation	yes *no
-------------------------	------------

This parameter can be enabled the direct control. Direct control meaning is control via direct communication object.

Starting characteristic of fan	yes *no
--------------------------------	------------

This parameter enables the fan to start from the OFF state with a defined fan speed. The fan can be switched on temporarily to a defined switch-on level. This switch-on level can be any of the available fan levels.

Switch on to switch-on level	1 2 *3
------------------------------	--------------

This switch-on level can be any of the available fan levels.

Minimum dwell period in switch on in s [1...65535]	1...*5...65535
--	----------------

The fan thus remains in the switch-on level until the set dwell time has elapsed.

7. COMMUNICATION OBJECTS (continued)

7.10 "Fan Coil" parameter (continued)

7.10.2 "A/B1 - Status Message" parameter

The screenshot shows a configuration window for the 'A/B1 - Status Message' parameter. It includes several sections: 'General' with 'Enable communication object "Status fan speed x" 1 bit' (radio buttons for yes/no, 'no' selected); 'Weather Alarm' with 'Enable communication object "Status fan speed" 1 byte' (radio buttons for yes/no, 'no' selected); 'Enable Input a..s' with 'Enable communication object "Status fan ON/OFF" 1 bit' (radio buttons for yes/no, 'no' selected); 'Enable Output A..J' with 'Enable communication object' (radio buttons for yes/no, 'no' selected); 'A/B1 - Fan' with 'A/B1 - Status Message' (radio buttons for yes/no, 'no' selected); 'A/B1 - Automatic Operation'; and 'A/B1 - Direct Mode'. At the bottom, there are tabs for 'Group Objects' and 'Parameter'.

Enable communication object "Status fan speed x" 1 bit	yes *no
--	------------

The data format for the fan level feedback is defined as 1 bit. Separate objects are defined separately for each fan level. When the fan level is changed, the actuator updates and transmits only the object values that change.

Meaning	*current fan speed required fan speed
---------	--

Current fan speed: The fan is actual operating state.

Required fan speed: The fan desired fan state. E.g. when the translation and dwell times are completed.

Fan operation mode	*no after a change after request after change or request
--------------------	---

This parameter defines the object send type.

Enable communication object "Status fan speed" 1 byte	yes *no
---	------------

The data format for the fan level feedback is defined as 1 byte.

Meaning	*current fan speed required fan speed
---------	--

Current fan speed: The fan is actual operating state.

Required fan speed: The fan desired fan state. E.g. when the translation and dwell times are completed.

Send object type	*no after a change after request after change or request
------------------	---

This parameter defines the object send type.

Enable communication object "Status fan ON/OFF" 1 bit	yes *no
---	------------

This ON telegram acts on a main switch that has to be switched on.

Send object type	*no after a change after request after change or request
------------------	---

This parameter defines the object send type.

Enable communication object "Status automatic" 1 bit	yes *no
--	------------

This parameter is enabled the communication object "Status automatic".

Send object type	*no after a change after request after change or request
------------------	---

This parameter defines the object send type.

7. COMMUNICATION OBJECTS (continued)

7.10 "Fan Coil" parameter (continued)

7.10.3 "A/B1 - Automatic Operation" parameter

General	Object value "automatic ON/OFF" switch on to automatic	<input checked="" type="radio"/> 0 <input type="radio"/> 1
Weather Alarm	Threshold value OFF <--> speed 1 in % [0...100]	10
Enable Input a...s	Threshold value speed 1 <--> speed 2 in % [0...100]	30
Enable Output A...J	Threshold value speed 2 <--> speed 3 in % [0...100]	70
A/B1 - Fan	Hysteresis threshold value in % +/- [0...20]	5
A/B1 - Status Message	Minimum dwell period in fan speed in s [0...65535]	0
A/B1 - Automatic Operation		
A/B1 - Direct Mode		

Object value "automatic ON/OFF" switch on to automatic	*1 0
--	---------

1: automatic operation is activated by a telegram with value 1
0: automatic operation is inactivated by a telegram with value 0

Threshold value OFF <--> speed 1 In % [0...100]	0...*10...100
Threshold value speed 1 <--> speed 2 In % [0...100]	0...*30...100
Threshold value speed 2 <--> speed 3 In % [0...100]	0...*70...100

A fan level switches on when its command value lower limit is reached or exceeded.

Hysteresis threshold Value in % +/- [0...20]	0...*5...100
--	--------------

The fan level switches off again as soon as its command value lower limit minus the hysteresis is undershot again.

Minimum dwell period in fan speed In s [0...65535]	*0...65535
--	------------

This parameter defines the dwell time for a fan speed of the fan until it switches to the next higher or lower fan speed.

0: no delay time for switching.

7. COMMUNICATION OBJECTS (continued)

7.10 "Fan Coil" parameter (continued)

7.10.4 "A/B1 - Direct Mode" parameter

General	Enable communication object "Switch speed x" 1 bit	<input type="radio"/> yes <input checked="" type="radio"/> no
Weather Alarm	Enable communication object "Fan speed UP/DOWN" 1 bit	<input type="radio"/> yes <input checked="" type="radio"/> no
Enable Input a...s	Enable communication object "Fan speed switch" 1 byte	<input type="radio"/> yes <input checked="" type="radio"/> no
Enable Output A...J		
A/B1 - Fan		
A/B1 - Status Message		
A/B1 - Automatic Operation		
A/B1 - Direct Mode		
A/B1 - Direct Mode		

Enable communication object "Switch speed x" 1 bit	yes *no
--	------------

The data format for the fan level feedback is defined as 1 bit. Separate three objects are defined separately for each fan level. If several ON/OFF telegrams are received consecutively in a short period of time at various communication objects Fan speed 1...3, the value last received by the fan control is the decisive value.

Enable communication object "Fan speed UP/DOWN" 1 bit	yes *no
---	------------

With multiple manual UP or DOWN switching, the target speed will be increased or reduced by a speed step. This is possible until the maximum or minimum possible speed is achieved.

Enable communication object "Fan speed switch" 1 byte	yes *no
---	------------

This parameter is enabled "Fan speed switch" communication object with percentage 0...100%.

7. COMMUNICATION OBJECTS (continued)

7.11 Function Chart

The following schematic indicates the function sequence. The functions are processed. Communication object enter the left side. Same box meaning same priority.

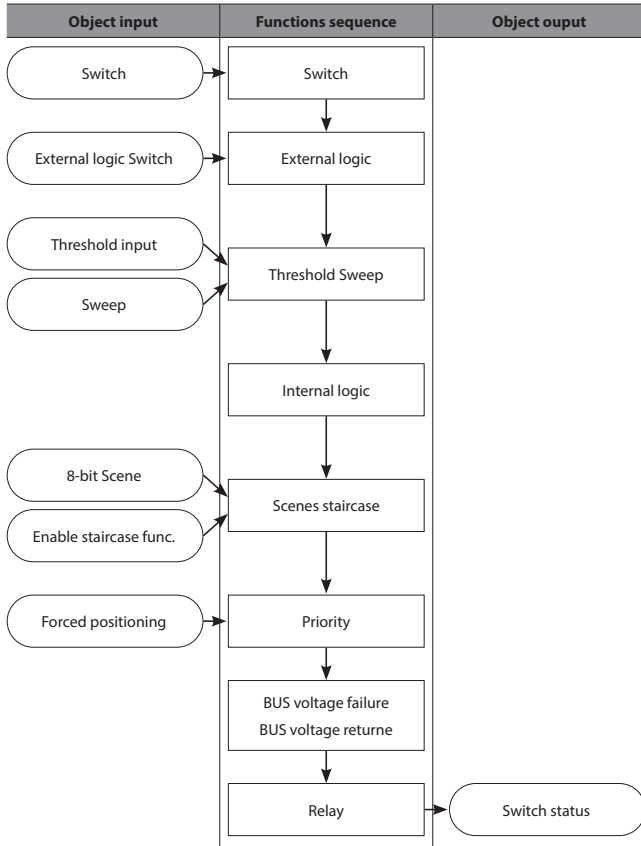

7. COMMUNICATION OBJECTS (continued)

7.12 Object Description

7.12.1 General Object Description

No	Object name	Name	DTP Type	Length	Flags
0	In operation	General	DPT 1.002	1 bit	CWT

You use this object to report device still alive and contacted the KNX line. Telegram value is select ON/OFF. If a telegram is not received, device may be defective or KNX cable will be interrupted. This communication object sends to the line cyclically.

1	Scene 8 bit	General	DPT 18.001	1 byte	CW
---	-------------	---------	------------	--------	----

This object is used to recall or store scenes. Up to 64 scenes are available on the Switch/Blind Actuator.

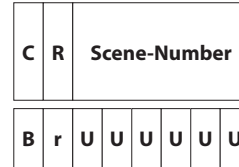

C: 0 – recall scene
1 – store scene
R: Reserved

The object to recall and store the scene (1...64) is sent via the group address. 8-bit scenes are stored in the Switch/Blind Actuator.

Scene	recall		save	
	Hex.	Des.	Hex.	Des.
1	0x00	0	0x80	128
2	0x01	1	0x81	129
3	0x02	2	0x82	130
4	0x03	3	0x83	131
5	0x04	4	0x84	132
6	0x05	5	0x85	133
7	0x06	6	0x86	134
8	0x07	7	0x87	135
9	0x08	8	0x88	136
10	0x09	9	0x89	137
11	0x0A	10	0x8A	138
...
63	0x3E	62	0xE2	190
64	0x3F	63	0xE3	191

2	Disable/enable man. operation	General	DPT 1.003	1 byte	CRW
---	-------------------------------	---------	-----------	--------	-----

The manual operation can be enabled or disabled with this communication object. If the manual operation is disabled, the manual control button cannot be enabled the manual operation.

The object is:
0 = manual button enabled
1 = manual operation cannot be enabled by the button.

3	Wind alarm	General	DPT 1.005	1 byte	CWTU
4	Rain alarm				
5	Frost alarm				

Active weather sensors can be monitored cyclically. The device expects a telegram from sensor within the cycle time. If the telegram doesn't receive within the cycle time or the value 1 is received, the blinds are moved to parameterized position. The blind control telegrams are ignored until the device is received telegram value 0.

The monitoring period is restarted each telegram is received from weather sensor. The wind alarms are connected each other via OR gate.

The object is:
0 = no alarm
1 = alarm active

7. COMMUNICATION OBJECTS (continued)

7.13 Input Object Description

No	Object name	Name	DTP Type	Length	Flags
5	Disable	Input a	DPT 1.003	1 bit	CW

0: enable input
1: disable input

This object is only visible if it is used as an input. Via the group address linked to this object blocking of the respective input channel is turned on or off.

When a disabled input is enabled, no telegrams are sent on the bus, even if the state of the input has changed during blocking. If the input is just being operated as it is being enabled, the input behaves as if the operation has just commenced.

No	Object name	Name	DTP Type	Length	Flags
6	Switch Switch - short	Input a	DPT 1.001	1 bit	CWT

0: OFF
1: ON

Switching telegrams are sent via the group address linked with this object. Object can be switched by actuation of the ON, OFF or TOGGLE input.

No	Object name	Name	DTP Type	Length	Flags
6	Shutter up/down	Input a	DPT 1.008	1 bit	CT

The driving object is for moving the shutters "move UP" and "move DOWN".

0: Move upwards (UP)
1: Move downwards (DOWN)

No	Object name	Name	DTP Type	Length	Flags
6	Value	Input a	CWT

An adjustment can be made as to whether a value telegram is to be sent as a reaction to a short and / or long button press action when a push button is pressed or released. Additionally, it is possible to configure whether the value associated with the long button press action is sent via a second object.

1 bit [0 / 1]	DPT 1.001	switch command
2 bit [0...3]	DPT 2.001	forced operation
1 byte [0...255]	DPT 5.001	brightness value
2 byte [-32768...32767]	DPT 7.001	signed value
2 byte [0...65535]	DPT 8.001	unsigned value
4 byte [float value]	DPT14.068	temperature
4 byte [0...4294967295]	DPT12.001	value unsigned

No	Object name	Name	DTP Type	Length	Flags
7	Switch - long	Input a	DPT 1.008	1 bit	CT

0: OFF
1: ON

Switching telegrams for long push button press are sent via the group address linked with this object if the parameter "Number of objects for short/long operation" is set to "2 object".

No	Object name	Name	DTP Type	Length	Flags
7	Dimming brighter / darker	Input a	DPT 3.007	4 bit	CT

4 bit: B, U₃
1

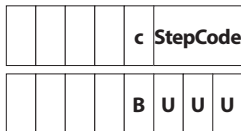

c = {0,1}
StepCode = [000b...111b]

c	Increase or decrease the brightness	0 – recall scene 1 – store scene
StepCode	The amount of intervals into which the range of 0 % ... 100 % is subdivided or the break indication.	- 001b ... 111b: Step Number of interval = (2) ^(StepCode-1) - 000b : Break

The dimming telegrams are sent to the dimming actuator via the group address linked with this object. In the process, a long push button action produces a "100 % dimming" telegram. A stop command is sent when the push button is released.

No	Object name	Name	DTP Type	Length	Flags
7	Shutter stop / lamella	Input a	DPT 1.007	1 bit	CT

The stop-/lamella adjustment object is for the adjustment of the lamellas and additional it stops a running movement of the shutter.

0: Stop / lamella UP
1: Stop / lamella DOWN

No	Object name	Name	DTP Type	Length	Flags
7	Value	Input a	CWT

An adjustment can be made as to whether a value telegram is to be sent as a reaction to a short and / or long button press action when a push button is pressed or released. Additionally, it is possible to configure whether the value associated with the long button press action is sent via a second object.

1 bit [0 / 1]	DPT 1.001	switch command
2 bit [0...3]	DPT 2.001	forced operation
1 byte [0...255]	DPT 5.001	brightness value
2 byte [-32768...32767]	DPT 7.001	signed value
2 byte [0...65535]	DPT 8.001	unsigned value
4 byte [float value]	DPT14.068	temperature
4 byte [0...4294967295]	DPT12.001	value unsigned

No	Object name	Name	DTP Type	Length	Flags
8	Shutter upper limit position	Input a	DPT 1.002	1 bit	CW

This object the shutter actuator indicates it is in the upper limit position. This object is used for 1 button options.

0: No Upper end limit
1: Upper end limit

No	Object name	Name	DTP Type	Length	Flags
8	Value (temperature)	Input a	DPT 14.068	32 bit	CT

The value type is selected "floating point" this object is created. For more information look Value communication object.

7. COMMUNICATION OBJECTS (continued)

7.13 Input Object Description (continued)

No	Object name	Name	DTP Type	Length	Flags
9	Shutter lower limit position	Input a	DPT 1.002	1 bit	CW

This object the shutter actuator indicates it is in the lower limit position. This object is used for 1 button options.

0: No Lower end limit
1: Lower end limit

No	Object name	Name	DTP Type	Length	Flags
9	Value (temperature) - long	Input a	DPT 14.068	32 bit	CT

The value type is selected "floating point" this object is created. For more information look Value communication object.

7.14 Switch Object Description

No	Object name	Name	DTP Type	Length	Flags
95	Switch	Output A1	DTP 1.001	1 bit	CW

This object is used to switching of relay. If a logic operation is enabled, the output is calculated via logic combination.

The object is;
0 = switched ON
1 = switched OFF

No	Object name	Name	DTP Type	Length	Flags
96	Status switch	Output A1	DPT 1.001	1 bit	CRT

The current switching state of the channel is saved in the status object. It can be transmitted automatically its state changed.

This object is ;
0 = relay OFF position
1 = relay ON position

No	Object name	Name	DTP Type	Length	Flags
97	Enable staircase function	Output A1	DPT 1.003	1 bit	CRW

This object is used to activation of the staircase function. This object is enabled, the staircase function is activated.

The object is;
0 = disable
1 = enable

No	Object name	Name	DTP Type	Length	Flags
98	Staircase lighting duration	Output A1	DPT 7.007	2 byte	CRW

The staircase lighting duration is set via this object. The object resolution is second. In addition, the bus return state can be parameterized by the parameter at the staircase function tag.

The object is;
0 = must be greater than zero
.....
65535

No	Object name	Name	DTP Type	Length	Flags
99	Permanent ON	Output A1	DPT 1.001	1 bit	CW

This object is used to mask the other function. This meanings function is working back ground of the Permanent ON. If the Permanent ON object is set to off, the other function switch result can be visible on the output. After bus voltage return, the object is deactivated. This object feature is useful for cleaning person.

The object is;
0 = permanent ON active
1 = deactivate

No	Object name	Name	DTP Type	Length	Flags
100	External logic input	Output A1	DPT 1.001	1 bit	CW

This object is used to receive the switching data for the second input. The switch operation and external logic are respect with logic OR, AND.

The object is;
0 = logic state
1 = logic state

No	Object name	Name	DTP Type	Length	Flags
101	Forced positioning	Output A1	DPT 2.001	2 bit	CW

This object is used to the switching state of the output is directly determined by this object. The first bit is switching state and the second bit is activated or deactivated the forced control.

Bit Field	Description
Bit 0	Switching state "0": switching off "1": switching on
Bit 1	Forced control "0": inactive "1": active

No	Object name	Name	DTP Type	Length	Flags
102	Sweep	Output A1	DPT 1.017	1 bit	CW

This object is used to trigger the sweep function.

The object is;
0 = do nothing
1 = trigger

7. COMMUNICATION OBJECTS (continued)

■ 7.15 Blind Object Description

No	Object name	Name	DTP Type	Length	Flags
95	Move blind/shutter up-down	Output A	DPT 1.008	1 bit	CW

When the telegram is received from bus, blind is moved to the direction (the value 0 or 1) of movement of the set time.

The object is;
0 = up
1 = down

96	Slat adjustment/stop up-down	Output A	DPT 1.007	1 bit	CW
----	------------------------------	----------	-----------	-------	----

While blind is moving, the telegram is received then the blind movement is stopped. Other time the blind slat can be adjusted.

The object is;
0 = stop/slat move one step open
1 = stop/slat move one step close

97	Blind/shutters up-down limit Enable limitation	Output A Output A/B	DPT 1.008 DPT 1.003	1 bit	CW
----	---	------------------------	------------------------	-------	----

This communication objects are controlled by "Limit travelling range" parameter. Blind up or down end position can be limited by this communication object. The blind stops automatically when the configured upper or lower end position have been reached. After the bus voltage, return object value is set to 0 so this meaning upper end position is limited.

For the first communication object "Blind/shutters up-down limit";
0 = limited upper end position active
1 = limited lower end position active

For the second communication object "Output A/B, Enable limitation"
0 = limitation disable
1 = limitation enable

98	Move to position height 0...255	Output A	DPT 5.001	1 byte	CW
----	---------------------------------	----------	-----------	--------	----

If device is received this telegram, the blind is moved to height determined by the percentage of value. After the blind moving operation is finished, the slats are returned its previous position.

While the blind is moving, the "Move slat 0...255" command is received from the bus. If the blind is reached its target position, the slats are set to the received position.

The object is;
0 = upper end position %0
...
255 = lower end position %100

99	Move slats 0...255	Output A	DPT 5.001	1 byte	CW
----	--------------------	----------	-----------	--------	----

If the device is received this communication object, the slats are moved to the desired position.

The object is;
0 = slats open %0
...
255 = slat closed %100

100	Move to position 1, 2	Output A	DPT 1.022	1 bit	CW
101	Move to position 3, 4				

This object is used to move to the blind saved preset position. After the position has been reached, the slat position is move to the own preset position.

The object is;
0 = move to position 1 or 3
1 = move to position 2 or 4

102	Set position 1, 2	Output A	DPT 1.022	1 bit	CW
103	Set position 3, 4				

This object is used to save the current position of blind. If the telegram value is received 0, the current position is stored as the new position 1 or 3. If the telegram value is received 1, the current position is stored as the new position 2 or 4.

The object is;
0 = set to position 1 or 3
1 = set to position 2 or 4

104	Trigger reference movement	Output A	DPT 1.008	1 bit	CW
-----	----------------------------	----------	-----------	-------	----

This object is triggered the reference movement. If the telegram is received, the blind is moved up or down end position. Then the blind can return its last position or desired position. End of reference movement, the device is updated travel times.

The travel time operation can be interrupted by
• Weather alarm, forced operation, block function
• Manual operation
• Move to position UP or DOWN commands

The object is;
0 = no reaction
1 = trigger the reference movement (UP – DOWN – UP)

105	Block	Output A	DPT 1.003	1 bit	CWTU
-----	-------	----------	-----------	-------	------

The state of the blind cannot changed by other control commands as long as block telegram with the value 1 is received. You can define the reaction of output relay via parameters.

The object is;
0 = operation enable
1 = operation disable

7. COMMUNICATION OBJECTS (continued)

■ 7.15 Blind Object Description (continued)

No	Object name	Name	DTP Type	Length	Flags
106	Forced operation 1 bit	Output A	DPT 1.003	1 bit	CWTU

If the telegram is received (value 1), the blind is moved to parameterized position and the blind is locked for the movement command. After the forced operation is disabled by the object (value 0), the blind is moved to parameterized position.

The object is:
0 = operation enable
1 = forced active / operation disable

106	Forced operation 2 bit	Output A	DPT 2.002	2 bit	CWTU
-----	------------------------	----------	-----------	-------	------

If the telegram is received value 2 or value 3, the blind is moved to UP (2) or DOWN (3) and the blind is locked for the movement command. After the forced operation is disabled by the object (value 0) or (value 1), the blind is moved to parameterized position.

The object is:
0 = operation enable
1 = operation enable
2 = forced active, move UP / operation disable
3 = forced active, move DOWN / operation disable

107	Status height 0...255	Output A	DPT 5.001	1 byte	CRT
-----	-----------------------	----------	-----------	--------	-----

The blind position of drive is available as a value 0...255 percentage %0...%100. The height status is to be transmitted or read out via this object.

The height status object is only updated when the blind has reached a target position after movement.

The object is:
0 = upper end position %0
...
255 = lower end position %100

108	Status slat 0...255	Output A	DPT 5.001	1 byte	CRT
-----	---------------------	----------	-----------	--------	-----

The blind slat position of drive is available as a value 0...255 percentage %0...%100. The slat status is to be transmitted or read out via this object.

The slat status object is only updated when the blind has reached a target position after movement.

NOTE: This object is only available in the venetian blind type.

The object is:
0 = slat open %0
...
255 = slat close %100

109	Status upper end position	Output A	DPT 1.011	1 bit	CRT
-----	---------------------------	----------	-----------	-------	-----

The blind is reached the upper end position, the device sends information.

The object is:
0 = the blind is not in upper end position
1 = the blind is in upper end position

110	Status lower end position	Output A	DPT 1.011	1 bit	CRT
-----	---------------------------	----------	-----------	-------	-----

The blind is reached the lower end position, the device sends information.

The object is;
0 = the blind is not in lower end position
1 = the blind is in lower end position

7. COMMUNICATION OBJECTS (continued)

7.16 Valve Object Description

No	Object name	Name	DTP Type	Length	Flags
95	Control valve HEATING	Control Input	DPT 5.001	1 byte	CW

Via this object, command value for heating operation is sent.

96	Control valve COOLING	Control Input	DPT 5.001	1 byte	CW
----	-----------------------	---------------	-----------	--------	----

Via this object, command value for cooling operation is sent.

97	Toggle Heating/Cooling	Control Input	DPT 1.100	1 bit	CW
----	------------------------	---------------	-----------	-------	----

If the HVAC System parameter has been selected one control four pipe with switch or two control two pipe with switch, this object is enabled.

If the parameter Object value for HEATING the object is selected 1:

1 : HEATING

0 : COOLING

If the parameter Object value for HEATING the object is selected 0:

1 : COOLING

0 : HEATING

98	Fault control value	Control Input	DPT 1.005	1 bit	CRT
----	---------------------	---------------	-----------	-------	-----

If the control input telegram does not arrive in the monitoring period, this object set TRUE and send to bus.

0 : no fault

1 : fault

99	Block	Valve HEATING Valve COOLING	DPT 1.003	1 bit	CW
----	-------	--------------------------------	-----------	-------	----

This object is used to block the valve operation. The valve does not respond any control input values.

100	Forced operation	Valve HEATING Valve COOLING	DPT 1.003	1 bit	CW
-----	------------------	--------------------------------	-----------	-------	----

This object is used to force the valve-desired state. This state can be configure via Value position on forced operation in % [0...100] parameter.

0 : end of forced operation

1 : start of forced operation

101	Trigger valve purge	Valve HEATING Valve COOLING	DPT 1.017	1 bit	CW
-----	---------------------	--------------------------------	-----------	-------	----

This object is use to triggered the valve purge.

0 : end of valve purge

1 : start of valve purge

102	Status valve purge	Valve HEATING Valve COOLING	DPT 1.003	1 bit	CRT
-----	--------------------	--------------------------------	-----------	-------	-----

The status of the valve purge is visible via this communication object.

103	Status valve position	Valve HEATING Valve COOLING	DPT 1.001 DPT 1.005	1 bit 1 byte	CRT
-----	-----------------------	--------------------------------	------------------------	-----------------	-----

The status of valve position is visible vis this communication object.

If the object is configured 1-bit:

0 : valve position is zero

1 : valve position is not zero

If the object is configured 1 byte:

0...255 : valve position is show via percentage

7. COMMUNICATION OBJECTS (continued)

7.17 Fan Object Description

No	Object name	Name	DTP Type	Length	Flags
95	Fan speed switch	Fan	DPT 5.010	1 byte	CW

This object is used to switch on fan speed via 1-byte object. If the object received, automatic mode is set OFF.

Hex	Fan Speed
00	0 (Fan OFF)
01	Fan speed 1
02	Fan speed 2
03	Fan speed 3
>03	ignored

96	Switch speed 1	Fan	DPT 1.001	1 bit	CW
97	Switch speed 2	Fan	DPT 1.001	1 bit	CW
98	Switch speed 3	Fan	DPT 1.001	1 bit	CW

This object is used to receive a control value for fan speed. An OFF telegram to one of the three communication objects, fan speed 1-3, switch off the fan completely. If the object received, automatic mode is set OFF.

0 : fan OFF

1 : fan ON

99	Fan speed UP/DOWN	Fan	DPT 1.007	1 bit	CW
----	-------------------	-----	-----------	-------	----

This object is used to switched one fan speed further up or down via 1-bit telegram.

0 : fan speed DOWN

1 : fan speed UP

100	Status fan ON/OFF	Fan	DPT 1.001	1 bit	CT
-----	-------------------	-----	-----------	-------	----

The status of fan coil channel is visible via this communication object.

0 : complete fan coil channel inactive (all outputs OFF)

1 : any output of fan coil channel is switched ON

101	Status fan speed	Fan	DPT 5.010	1 byte	CRT
-----	------------------	-----	-----------	--------	-----

This object is used to display the fan speed via 1-byte object.

Hex	Fan Speed
00	0 (Fan OFF)
01	Fan speed 1
02	Fan speed 2
03	Fan speed 3

102	Status fan speed 1	Fan	DPT 1.001	1 bit	CRT
103	Status fan speed 2	Fan	DPT 1.001	1 bit	CRT
104	Status fan speed 3	Fan	DPT 1.001	1 bit	CRT

Only visible if the Enable communication object "Status fan speed x" 1 bit is configured to yes.

0 : fan level x deactivated

1 : fan level x activated

105	Forced operation	Fan	DPT 1.003	1 bit	CW
-----	------------------	-----	-----------	-------	----

This object used to set fan desired forced position independently from the control value.

0 : no forced operation

1 : forced operation

106	Automatic ON/OFF	Fan	DPT 1.003	1 bit	CW
-----	------------------	-----	-----------	-------	----

This object is used to switch the automatic mode. Automatic mode is switched off, if a telegram is received on a direct communication object.

If the object value "automatic ON/OFF" switched on to automatic parameter is selected "1":

0 : automatic operation OFF

1 : automatic operation ON

If the object value "automatic ON/OFF" switched on to automatic parameter is selected "0":

0 : automatic operation ON

1 : automatic operation OFF

107	Status automatic	Fan	DPT 1.003	1 bit	CW
-----	------------------	-----	-----------	-------	----

The object indicates the status of the automatic mode.

0 : inactive

1 : active